

Concatenated Irregular Variable Length Coding and Irregular Unity Rate Coding

R. G. Maunder and L. Hanzo

Communications Research Group

**School of Electronics and Computer Science,
University of Southampton, SO17 1BJ, UK.**

<http://www-mobile.ecs.soton.ac.uk>



Outline

- ❑ Serial concatenations of regular and irregular codes
- ❑ EXIT chart matching
- ❑ BER and complexity performance results
- ❑ Summary



Concatenation of regular codes

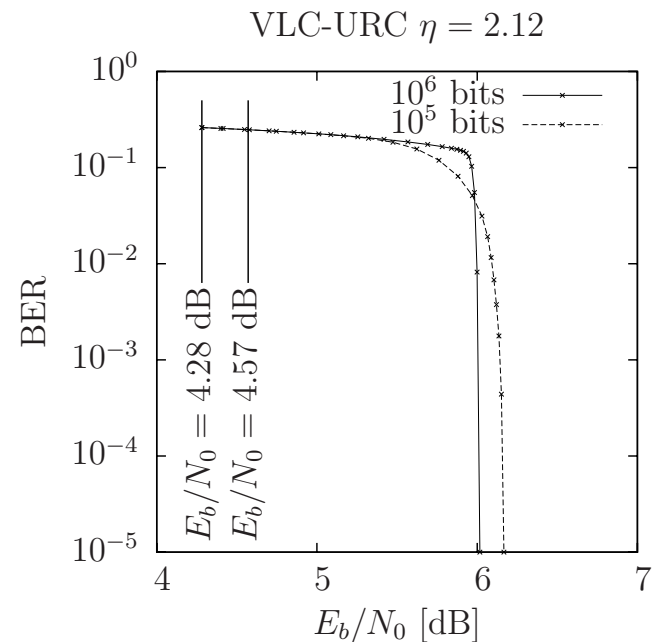
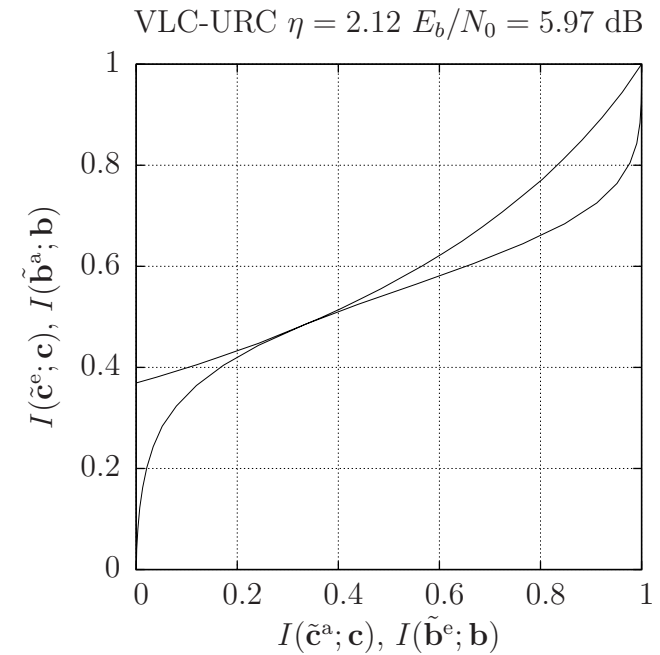
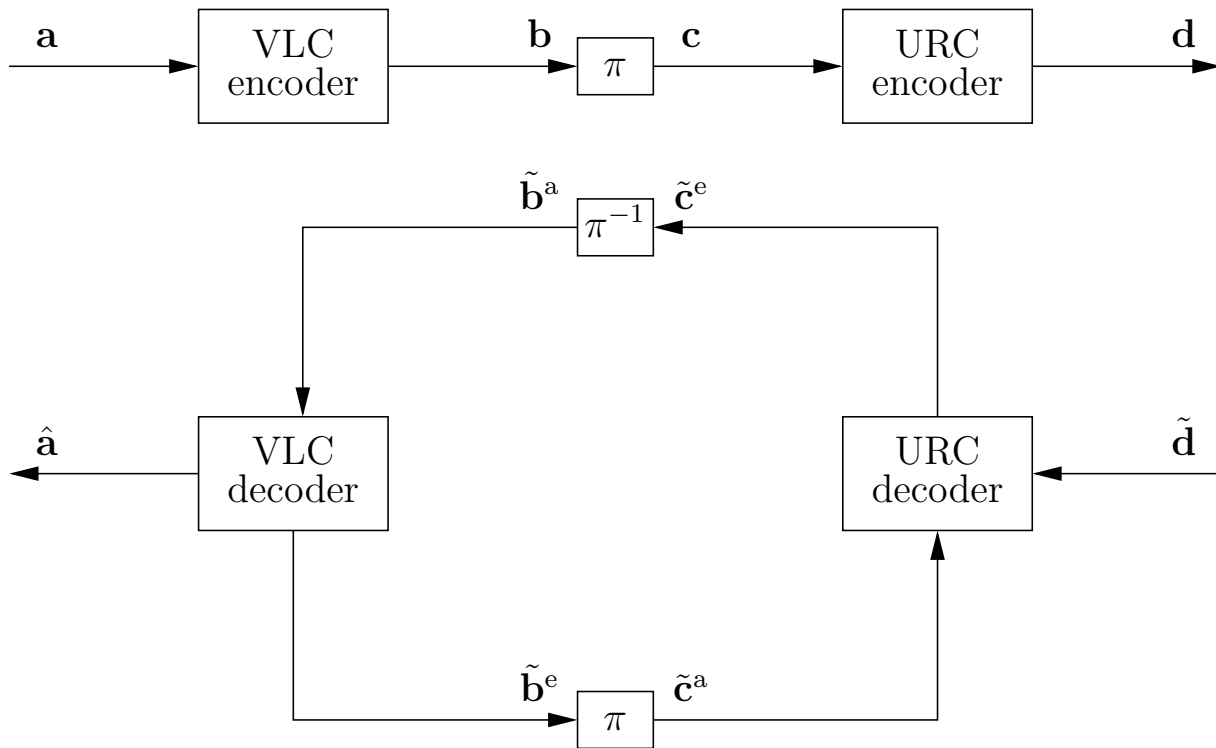

Concatenation of irregular and regular codes

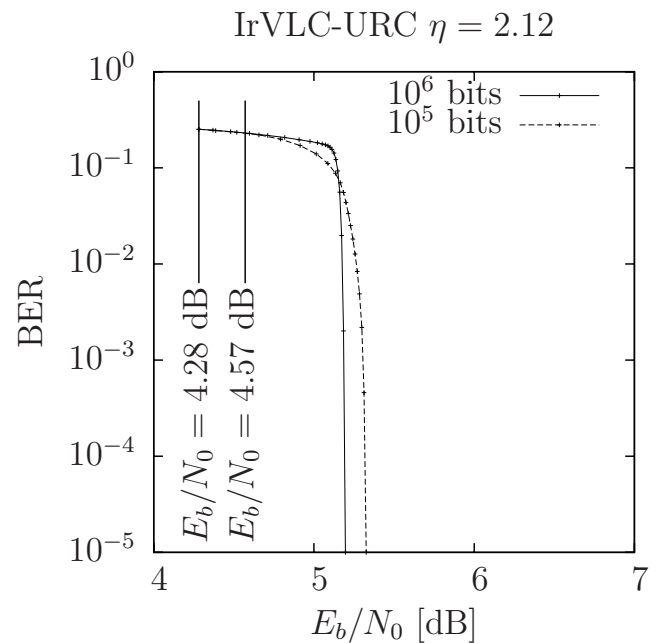
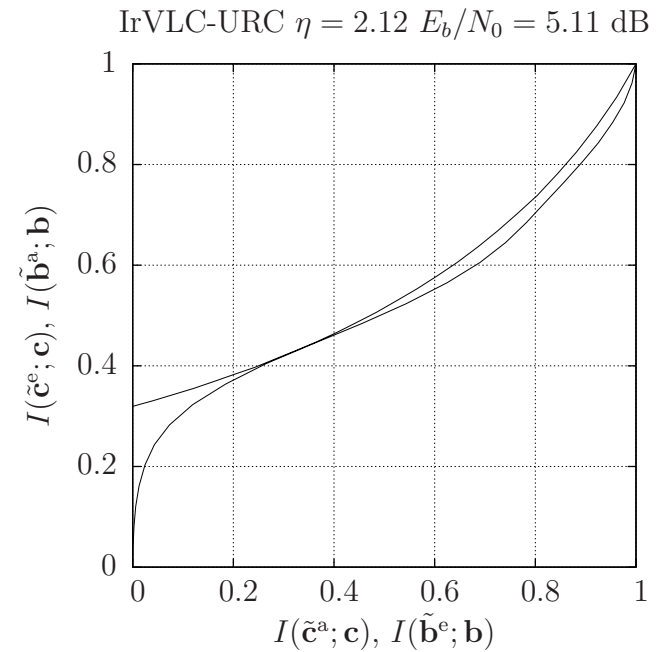
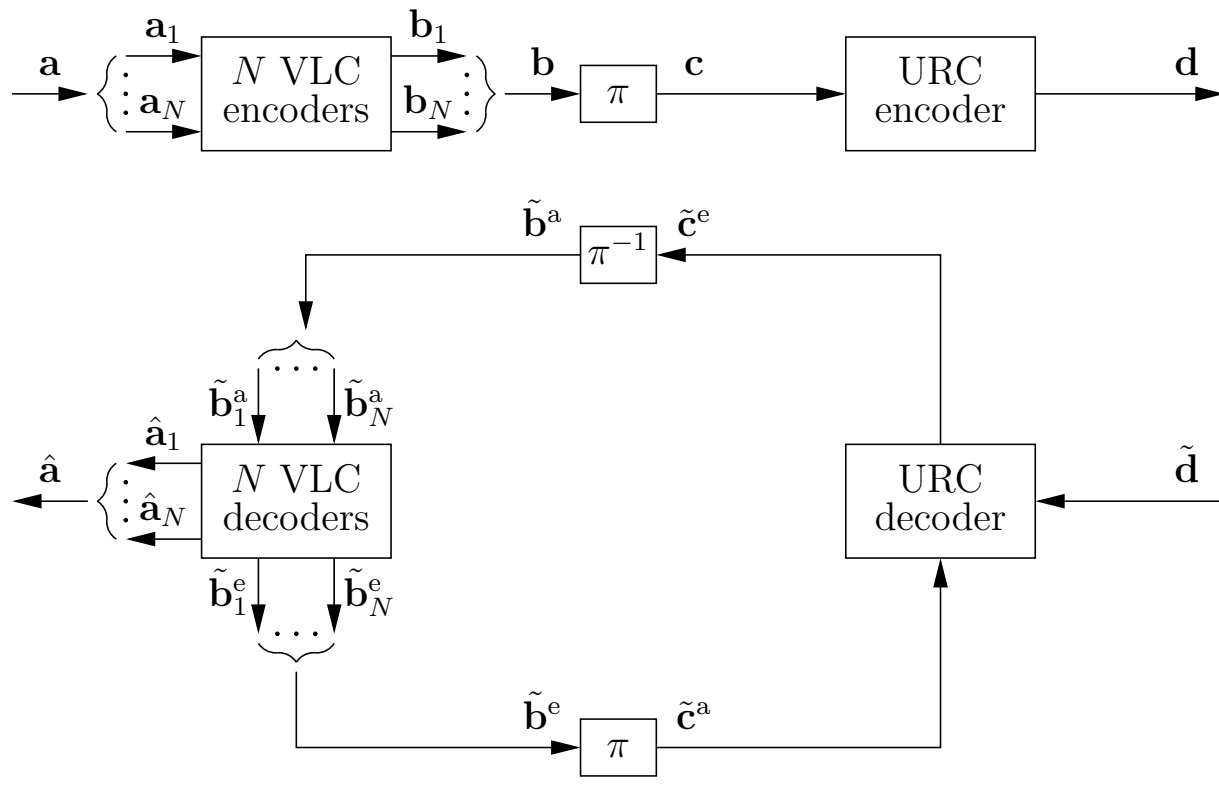

Concatenation of irregular codes

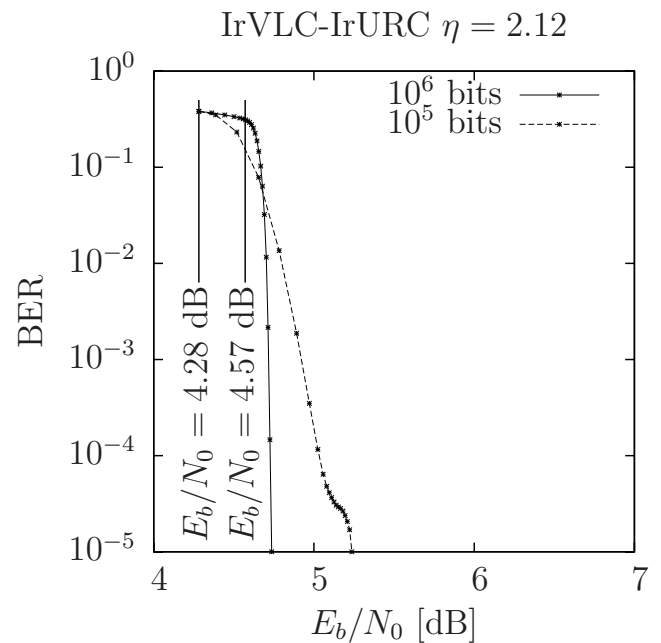
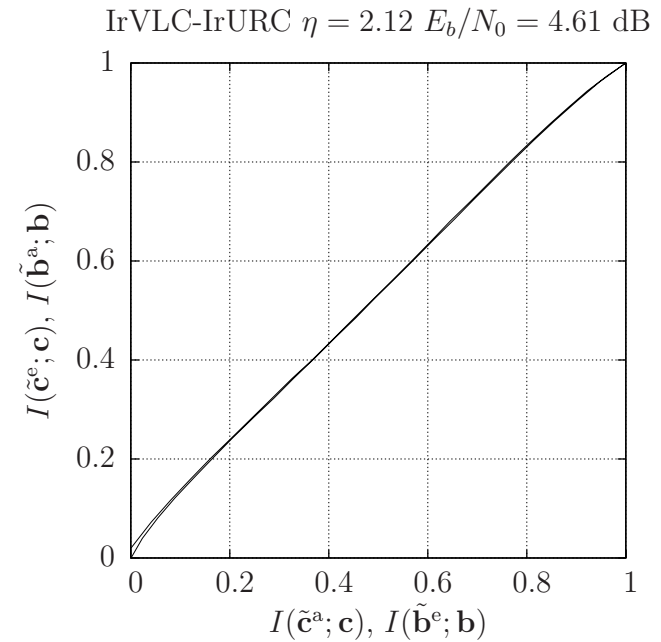
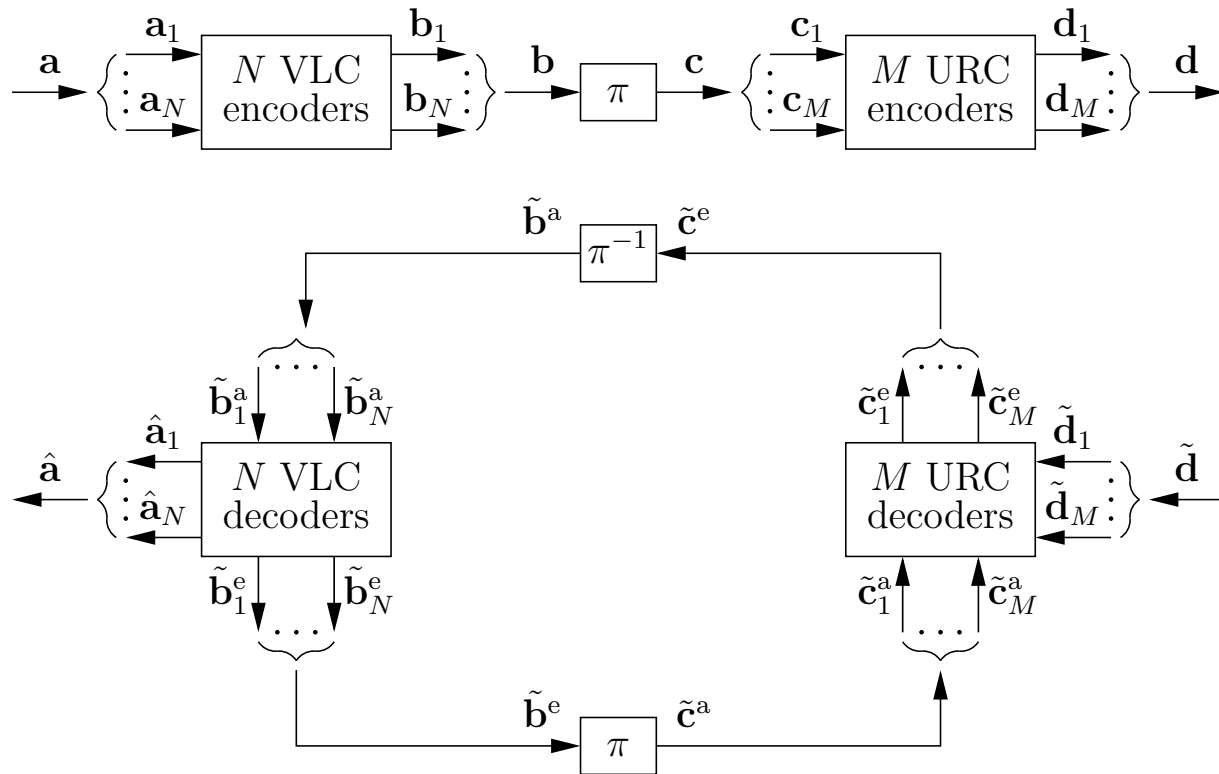

GA for designing component VLC codebooks

- ❑ Arbitrary EXIT curve
- ❑ Near-unity VLC-encoded bit entropy
- ❑ Low decoding complexity

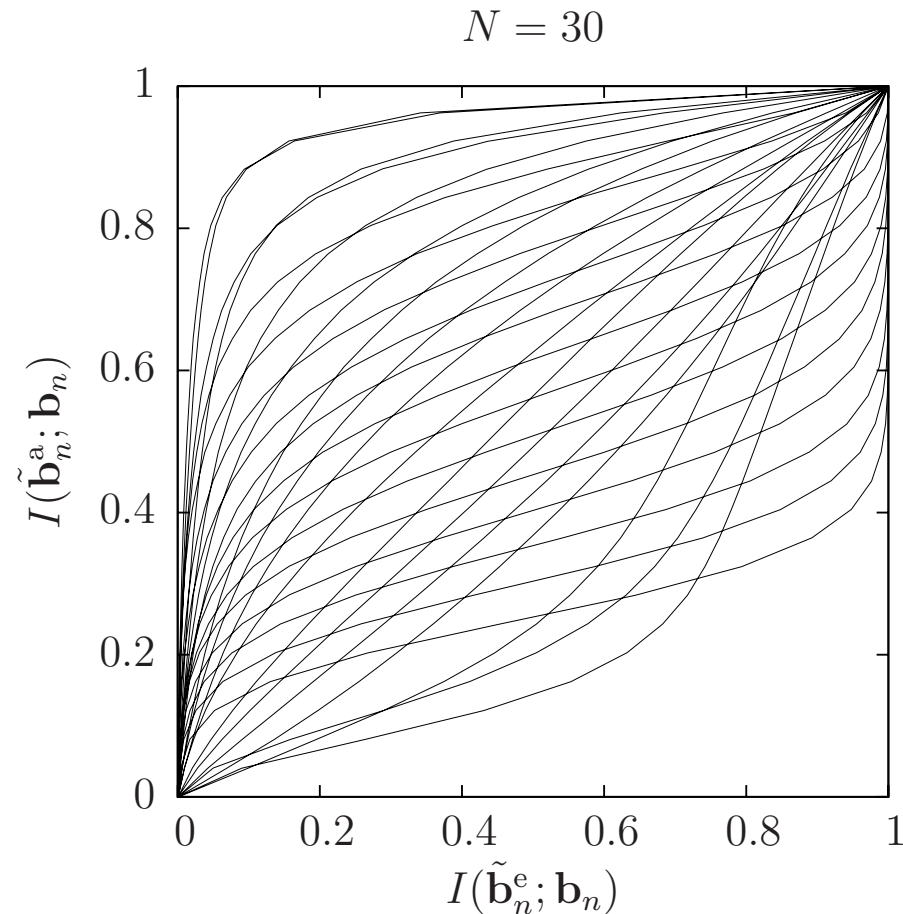

Full search for selecting component URC codes

$M = 10, E_b/N_0 = 4.74$ dB

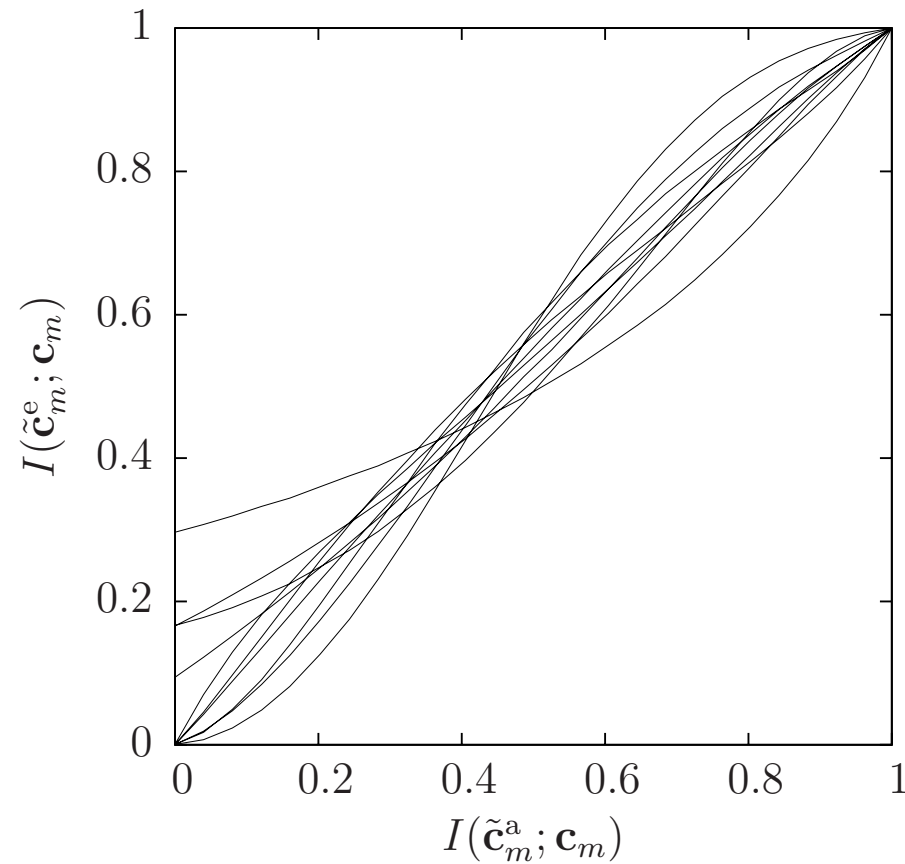

EXIT chart matching

$$I(\tilde{\mathbf{x}}^e; \mathbf{x}) = f_{\mathbf{x}} [I(\tilde{\mathbf{x}}^a; \mathbf{x})]$$

IrVLC EXIT function...

$$f_{\mathbf{b}} = \sum_{n=1}^N \alpha_n f_{\mathbf{b}_n},$$

where

$$\begin{aligned} \sum_{n=1}^N \alpha_n &= 1, \\ \alpha_n &\geq 0 \quad \forall n \in [1 \dots N], \\ R &= \sum_{n=1}^N \alpha_n R_n. \end{aligned}$$

IrURC EXIT function...

$$f_{\mathbf{c}} = \sum_{m=1}^M \alpha_m f_{\mathbf{c}_m},$$

where

$$\begin{aligned} \sum_{m=1}^M \alpha_m &= 1, \\ \alpha_m &\geq 0 \quad \forall m \in [1 \dots M]. \end{aligned}$$



Joint EXIT chart matching algorithm

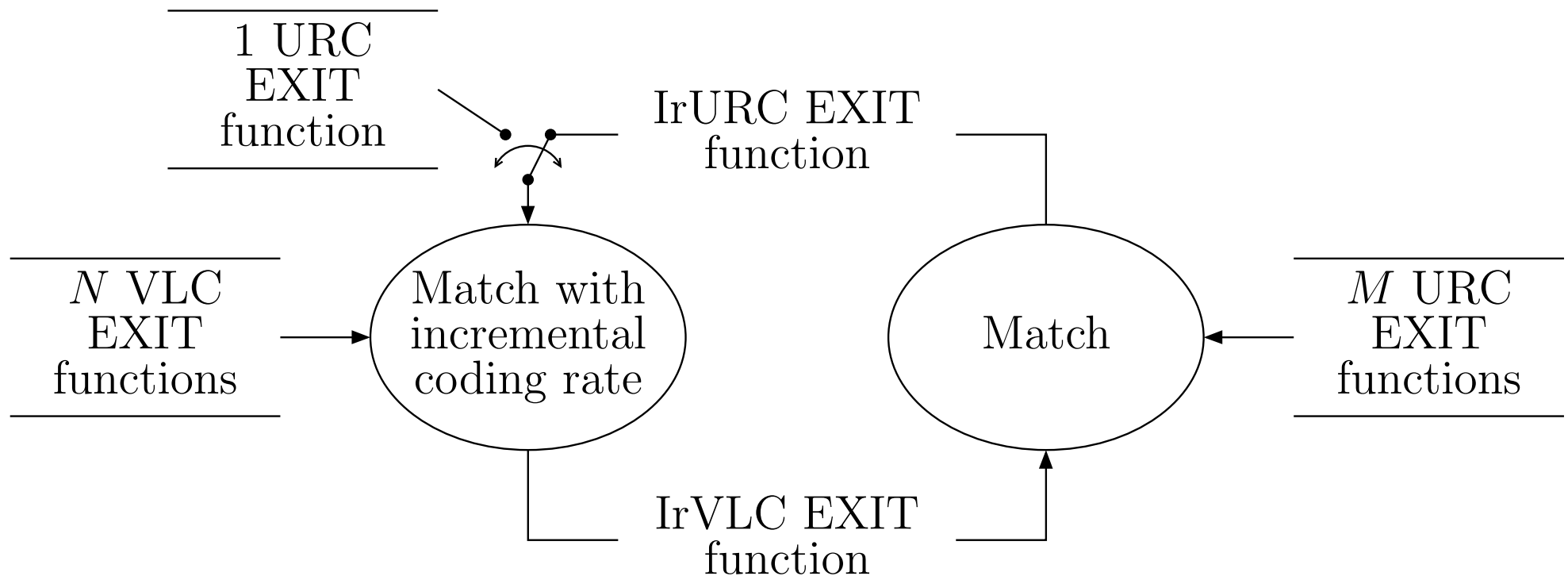

EXIT chart matching accuracy

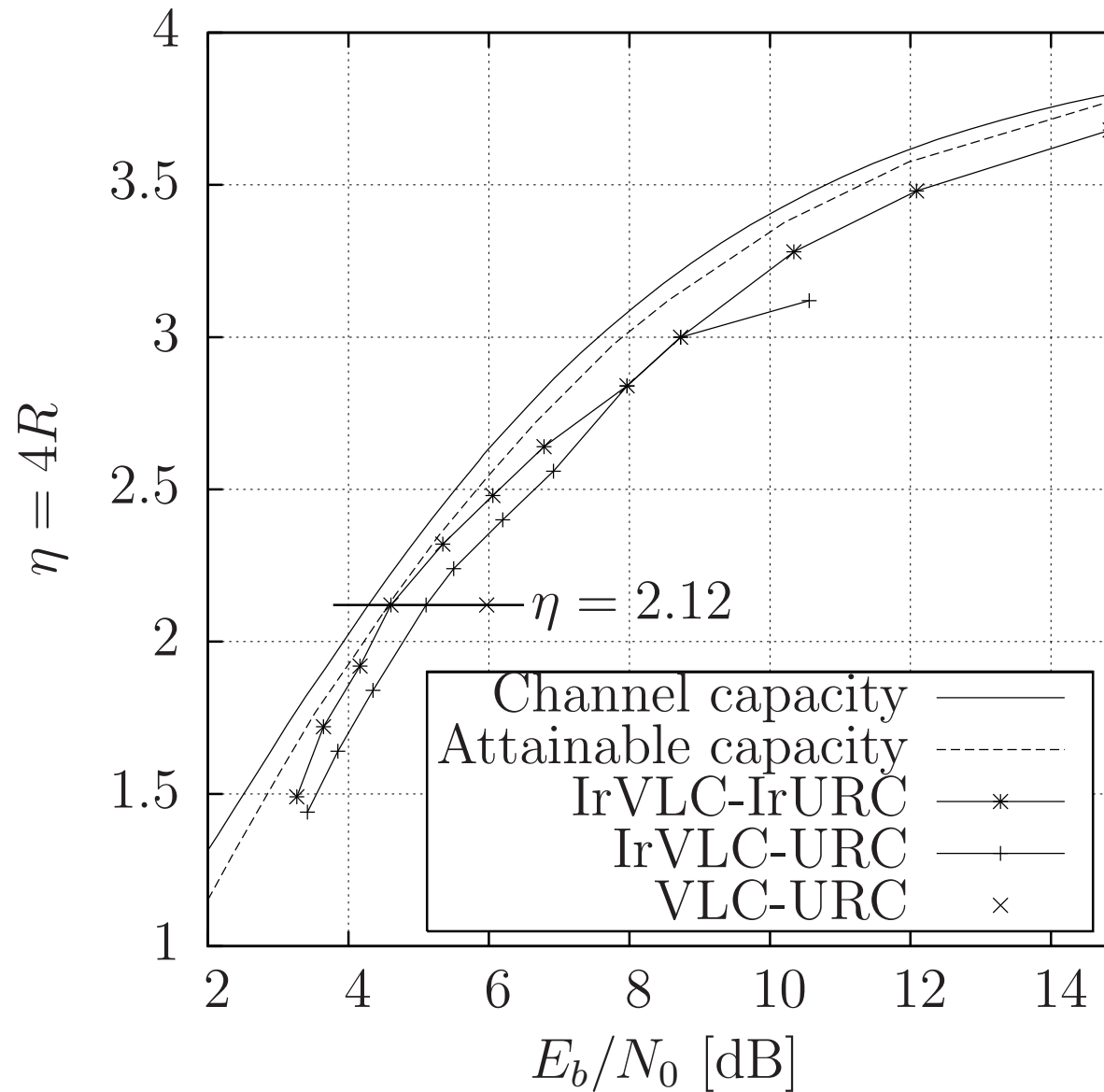

EXIT charts

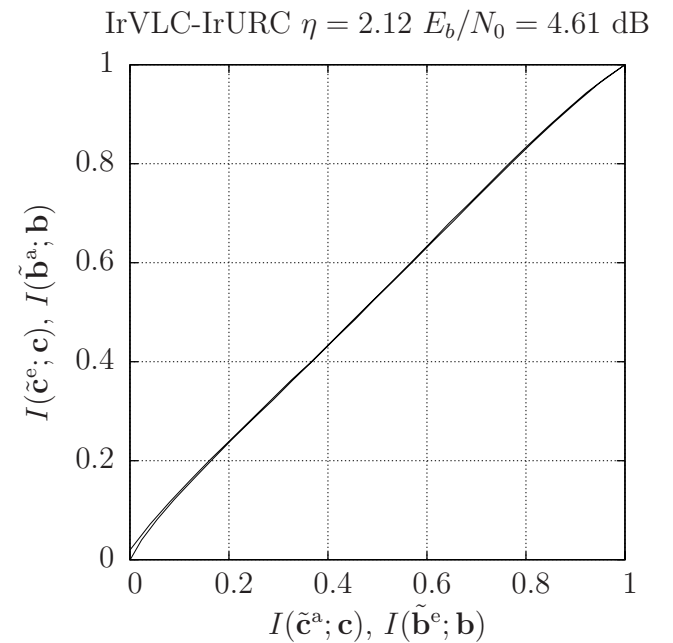
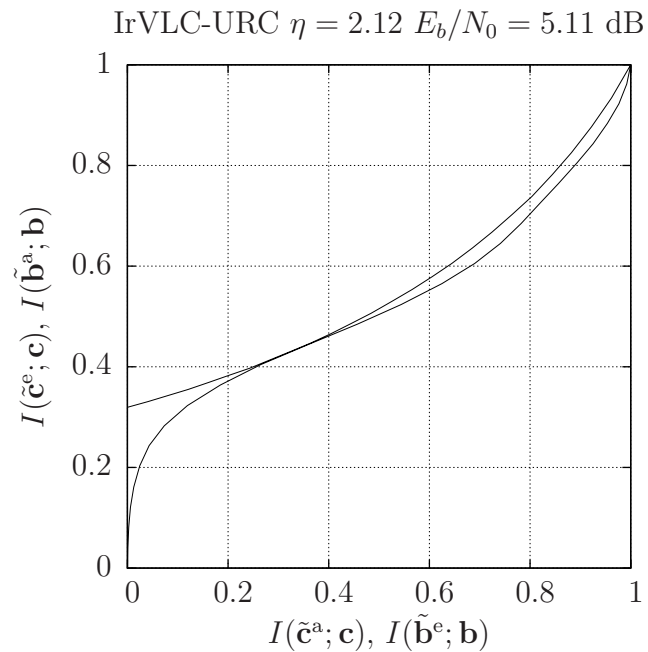
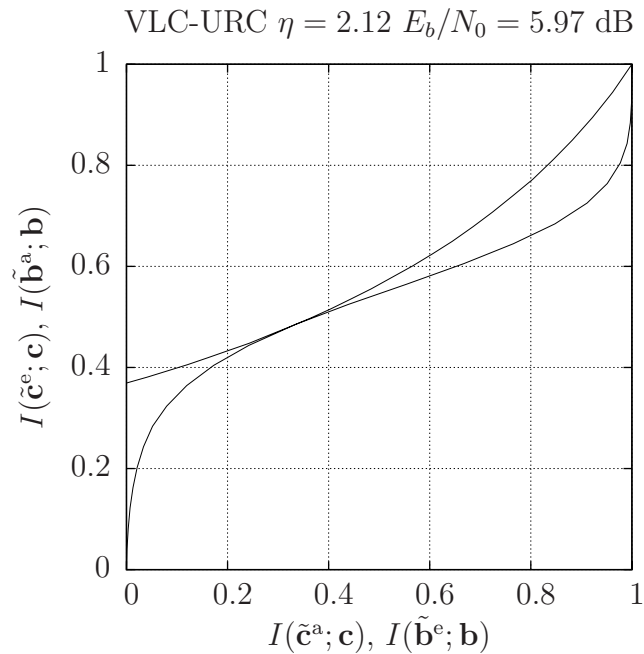

BER performance

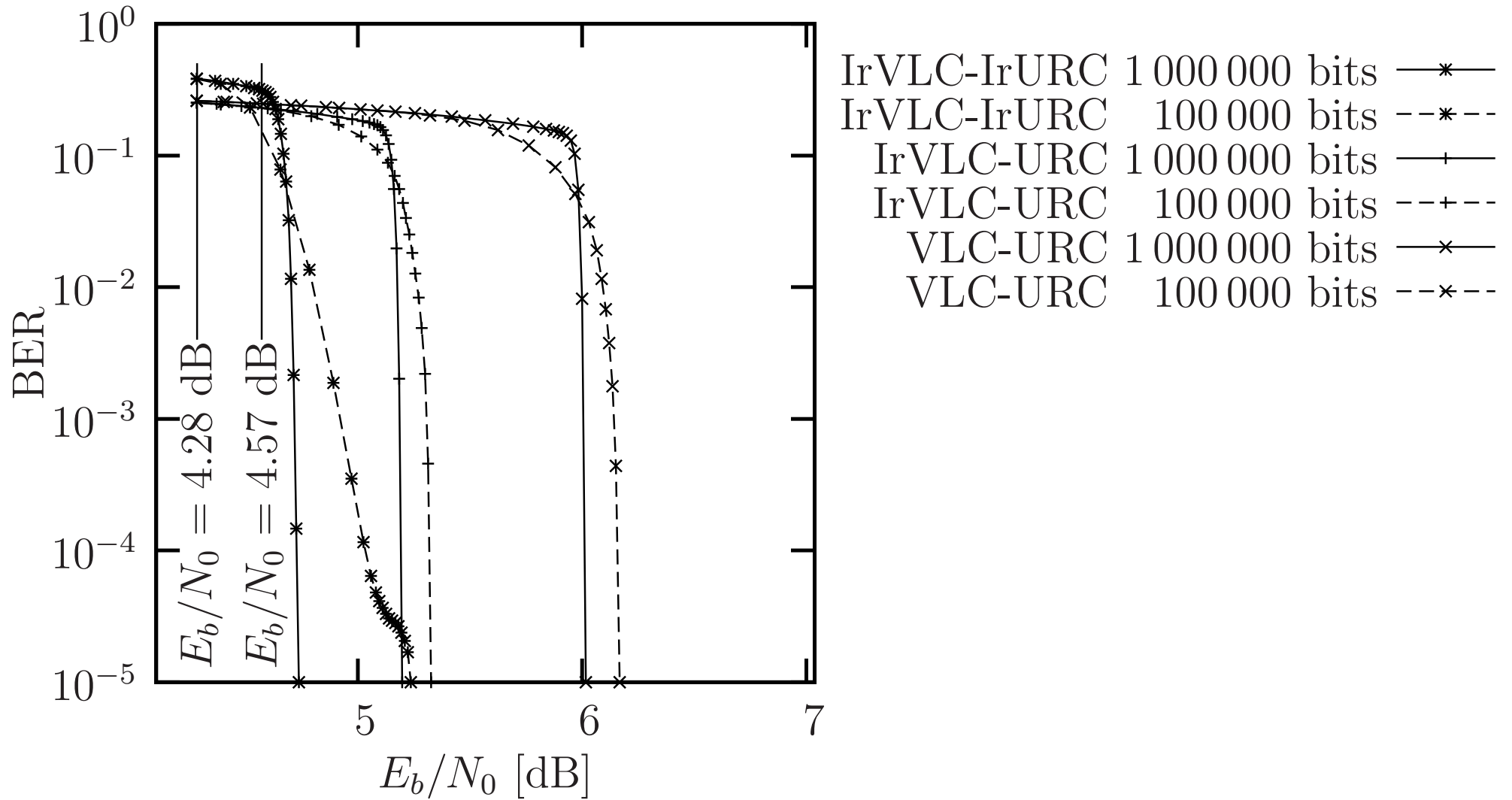

Decoding complexity

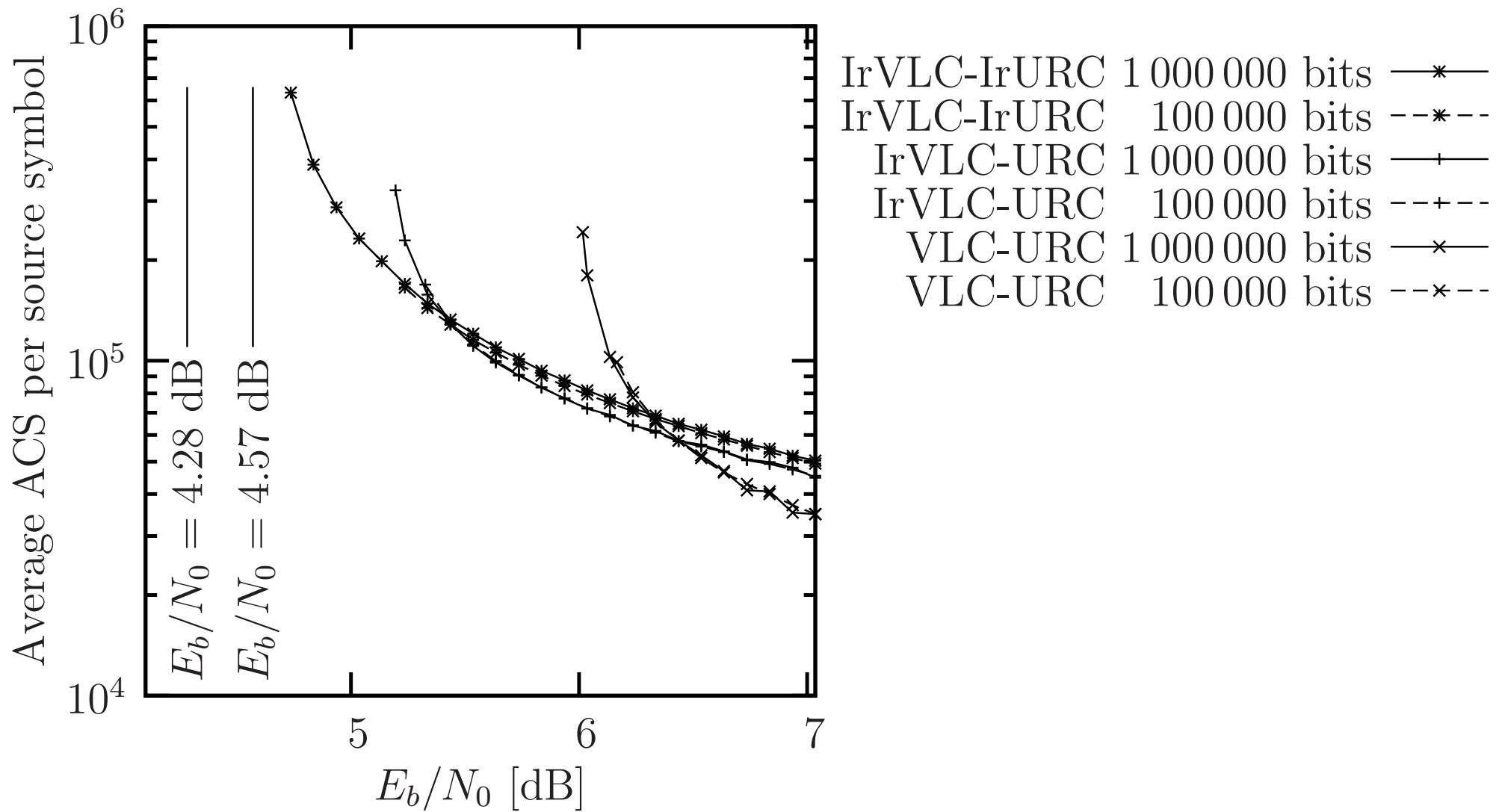

Summary

- ❑ Serial concatenations of regular and irregular codes
- ❑ EXIT chart matching
- ❑ BER and complexity performance results

