

# Iterative Detection Aided DL SDMA Systems Using Quantized Channel Impulse Response

Chun-Yi Wei, Du Yang, Lie-Liang Yang and Lajos Hanzo

School of ECS., Univ. of Southampton, SO17 1BJ, UK.

Tel: +44-23-80-593 125, Fax: +44-23-80-593 045

Email: lh@ecs.soton.ac.uk, http://www-mobile.ecs.soton.ac.uk

**Abstract**—An iterative detection aided Down-Link (DL) Space Division Multiple Access (SDMA) system is proposed. The Base Station (BS) requires DL Channel State Information (CSI) estimated by and fed back from the Mobile Station (MS) for separating the DL signals to be transmitted to the MSs from the BS. We investigate the achievable system performance subject to finite-accuracy CSI feedback. The achievable receiver performance is investigated with the aid of Extrinsic Information Transfer (EXIT) Charts. Furthermore, a novel concept, referred to as the EXIT-Chart Optimized CSI Quantization (ECO-CQ) is proposed. The ECO-CQ scheme assists the system in maintaining the lowest possible CSI feedback overhead, while ensuring that an open EXIT-tunnel is still attainable, which implies maintaining an infinitesimally low BER. Furthermore, we demonstrate that the proposed ECO-CQ may reduce the normalized feedback overhead compared to the conventional CQ. For instance, the ECO-CQ aided iterative DL-SDMA system using an average of  $q = 2.7$  quantization bits per CIR coefficient achieves a 10% normalized overhead reduction at  $E_b/N_0 = 5\text{dB}$ , compared to the conventional CQ aided benchmark system.

## I. INTRODUCTION

DownLink Space Division Multiple Access (DL-SDMA), which is capable of achieving a high user capacity by supporting a multiplicity of subscribers within the same frequency bandwidth [1], [2], constitutes an attractive MIMO subclass. The efficient design of the down-link transmitter is of paramount importance for the sake of achieving a high throughput. The effects of Multi-User Interference (MUI) may be mitigated by employing spatio-temporal pre-processing at the transmitter. Consequently, the down-link receiver's complexity may be reduced with the advent of transmit pre-processing at the base station, a technique, which is also often referred as Multi-User Transmission (MUT) [3].

In [4] a near-Maximum Likelihood (ML) detection aided DL-SDMA system was proposed, where perfect knowledge of the DL channels of all users was assumed by the Singular Value Decomposition assisted MUT. This perfect channel knowledge allows us to accurately separate the transmitted signals of the users at the MUT, but these channels have to be first accurately estimated by the DL receivers, which then quantize and signal the CIRs back to the MUT. This channel signaling is also subject to both signalling protocol-induced and propagation delays. Against this background, the novel contribution of this paper is that we analyze the achievable performance of iterative DL-SDMA systems employing imperfect Spatio-Temporal Channel Impulse Response at Transmitter (ST-CIRT) subject to finite-accuracy CSI feedback. Its impact on the convergence behavior of the system will be demonstrated by using Extrinsic Information Transfer (EXIT) charts [5]. The fundamental question is namely, how high this normalized ST-CIRT signaling overhead has to be? In response to this question, we propose an algorithm, which assists us in exploring the overhead required for maintaining an open EXIT-tunnel. Therefore we refer to the CSI quantization employing this algorithm as the EXIT-Chart Optimized CSI Quantizer (ECO-CQ), where the terminology will be further justified when the algorithm is detailed in Section IV.

In this paper *CSI Quantization* (CQ) will be referred to as ST-CIRT quantization. As detailed in [4], when the idealized

The financial support of the EU under the auspices of the Optimix project, as well as that the EPSRC UK is gratefully acknowledged.

scenario of having perfect knowledge of ST-CIRT is assumed, the iterative DL-SDMA system employing the Spatio-Temporal Pre-processing (STP) technique of [6] becomes capable of separating the signals destined for the different users at the base station's DL transmitter and hence results in a Multi-User Interference (MUI)-free single-user performance. In practice, the ST-CIRT required by the BS's DL transmitter may be obtained via a feedback channel from the DL receiver. The DL receiver is typically designed to feed back the quantized ST-CIRT to the BS by striking a balance between reducing the amount of the feedback information and maintaining a near-perfect MUI rejection. However, limited amount of feedback bits to BS results in having partial ST-CIRT only. Even if no errors are imposed on the feedback channel, the imperfect ST-CIRT conveyed by the limited feedback will result in a residual MUI and hence will further degrade the performance of the system. The overhead required by the transmission of the sampled ST-CIRT is determined by striking a trade-off between maintaining a low BER and a low feedback overhead.

In our forthcoming study, we will first illustrate the scenario of ST-CIRT feedback in Section II and provide a brief overview of CSI quantization in Section III, while in Section IV we summarize the proposed ECO-CQ algorithm. In Section V we outline the system model used. Our EXIT chart analysis is provided in Section VI, leading to the performance results of Section VII. Finally, we conclude our related discourse in Section VIII.

## II. THE SCENARIO OF ST-CIRT FEEDBACK

Consider the scenario when the BS periodically sends pilots to the DL receivers, so that the MSs may estimate the ST-CIRTs and use the allocated feedback channels to periodically feed back the ST-CIRTs, as illustrated in Figure 1. The DL channel and the UL feedback channels of the MSs are typically allocated in different bandwidths and the UL feedback information is assumed to be transmitted over the strongly protected UL control channel. Additionally, the BS may avoid the latency involved in awaiting the current ST-CIRTs by employing their predicted value generated by the ST-CIRT prediction [7] based on the previously received quantized ST-CIRTs.

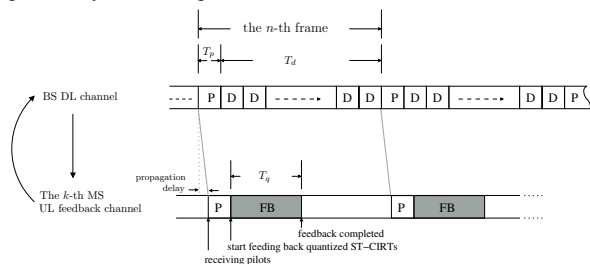

Fig. 1. The pilot-aided ST-CIRT estimation and ST-CIRT feedback

Let  $T_p$  denote the duration of a pilot symbol interval which typically identical to the data symbol interval and  $T_d$  denote the total duration of data-transmission symbol intervals between two pilots, as seen in Figure 1. The pilot symbols are used for sampling the fading channel's envelope according to the Nyquist

theorem [8], which requires a sampling rate  $f_s$  in excess of  $2f_d$ , where  $f_d$  denotes the normalized Doppler frequency. According to Figure 1, we have  $f_s = \frac{1}{T_p+T_d}$  and the condition of  $f_s = \frac{1}{T_p+T_d} \geq 2 \cdot f_d$  should be satisfied.

On the other hand, each MS estimates its ST-CIRTs using the received pilots as indicated in Figure 1. Assuming that there are  $(M \times N)$  ST-CIRT coefficients for each frame – which tacitly implies having a single complex-valued CIR tap – and the DL receivers quantize each ST-CIRT coefficient using  $q$  bits for the magnitude and  $q$  bits for the phase, the symbol interval  $T_q$  required for feeding back all the ST-CIRT coefficients of each transmission frame is given by

$$T_q = \frac{(M \cdot N) \cdot 2 \cdot q}{N_{bps}}, \quad (1)$$

where  $N_{bps}$  is the feedback transmission rate of the MS's Up-Link (UL) transmitter. The propagation delay of the channel may be negligible compared to  $T_q$ , due to the high number of ST-CIRT coefficients representing the MIMO channels.

Assuming that 10% DL pilot overhead is employed, we have  $T_p/T_d = 0.1$ . By letting  $f_s = \frac{1}{T_p+T_d} = 2 \cdot f_d$ , we may define the *normalized feedback overhead*  $\Lambda$  when the DL-receivers use  $q$ -bit quantization as

$$\Lambda_q = \frac{T_q}{T_d} \approx T_q \cdot 1.1 \cdot 2 \cdot f_d \approx T_q \cdot f_d. \quad (2)$$

Let us now consider two schemes. First, the MSs employ  $a$ -bit quantization to convey the ST-CIRT coefficients to the BS, which are subject to a feedback duration of  $T_a$ . In the second scheme, the MSs employing  $b$ -bit quantization to signal the ST-CIRT coefficients to the BS and have the corresponding feedback duration of  $T_b$ . Then we define the *normalized overhead reduction ratio*  $R_\Lambda$  associated with using  $b$  instead of  $a$  bits as

$$R_\Lambda = \frac{\Lambda_a - \Lambda_b}{\Lambda_a} = \frac{\frac{T_a - T_b}{T_d}}{\frac{T_a}{T_d}} = \frac{T_a - T_b}{T_a} = \frac{a - b}{a}. \quad (3)$$

#### Example 1: UL ST-CIRT overhead calculation

Consider a scenario, where the BS is equipped with  $M = 6$  DL transmit antennas and supports  $K = 3$  MSs. Each MS has  $N = 2$  receive antennas. When the MS employs a  $q = 3$ -bit quantization scheme, we require  $T_q = (6 \cdot 2) \cdot 2 \cdot 3/4 = 18$  symbols, where we assumed that the MS had a feedback transmission rate of  $N_{bps} = 2 \cdot 2$  bits per transmit symbol interval with the aid of using 4QAM and two transmit antennas. Let us furthermore assume that  $f_d = 0.001$ . Then the normalized overhead of the  $q = 3$ -bit quantization scheme is  $\Lambda_q = 0.018$ , i.e. 1.8%.

By contrast, when the system adopts a  $q = 2$ -bit ST-CIRT quantization instead of using  $q = 3$ -bit quantization, the resultant normalized overhead reduction ratio becomes  $R_\Lambda = (3 - 2)/3 = 0.33$ , i.e. 33%.

In this study, we did not take the channel prediction error into account in order to focus our attention on the investigation of the limited ST-CIRT feedback. Assuming that the channel prediction is perfect, the ST-CIRT coefficients are contaminated by the quantization error only. Hence, at every symbol interval we assume that the BS exploits the current ST-CIRT coefficients quantized by using the CQs. Consequently, in our forthcoming discourse the inaccuracy of the ST-CIRT employed by the BS will be dominated by the limited ST-CIRT feedback.

### III. INTRODUCTION TO CSI QUANTIZATION

In general, the quantization of ST-CIRT may utilize two different types of quantization schemes, namely Scalar Quantization

(SQ) and Vector Quantization (VQ) [9]. Vector quantization may be viewed as a generalization of SQ, where several ST-CIRT coefficients are quantized jointly. The attainable performance of VQ may be superior to that of SQ, because VQs exploit the correlation between the components of the input-vector [9], which in our case is either the spatial-domain or time-domain correlation of ST-CIRT coefficients. However, since in our study uncorrelated ST-CIRT coefficients are assumed, we employ a SQ scheme.

The accuracy of quantization is typically measured by the *distortion*  $D$ , defined as the mean squared error of the quantized signal  $h_q$ , namely as

$$D = E \{ (h_q - h)^2 \}, \quad (4)$$

where  $h$  is the signal to be quantized. In order to reduce the distortion  $D$ , we may use a high-resolution quantizer, which increases the number of quantization levels. Let us denote the number of quantization levels of the SQ by  $N_q$ . Then,  $q = \log_2(N_q)$  bits are required to represent  $N_q$  quantization levels. Furthermore, we may design the spacing between quantization levels to be uniform or nonuniform [10]. The benefit of using nonuniform quantization [9] is that the dynamic range that can be accommodated for a given number of bits may be significantly increased without increasing the average distortion of the quantizer. This is achieved by exploiting the knowledge of the Probability Distribution Function (PDF), of the input signal. A NonUniform Quantizer (NUQ) is typically designed by placing the quantization intervals more densely, where the PDF indicates a high relative frequency of the input samples. The most widely used codebook design algorithm is the Generalized Lloyd Algorithm (GLA) [9].

In our study, the magnitude of the input signal's PDF is assumed to be Rayleigh distributed, while the phase of it is assumed to be uniformly distributed. Therefore we employ a scalar ST-CIRT quantizer using NUQ to separately quantize the magnitude and phase of each CIR coefficient using  $q$  bits. We used the GLA [9] to obtain the  $N$  quantization intervals for both the magnitude and phase of the ST-CIRT coefficients.

In this paper we intend to focus our attention on the investigation of our iterative DL-SDMA system using limited-feedback, while perfect CSI is assumed to be available at the DL receivers. Furthermore, for the sake of simplicity, a free-error feedback channel is assumed. Hence, the mean square error of the ST-CIRT quantizer, which is denoted by  $\sigma_{ST-CIRT}^2$ , is given by

$$\sigma_{ST-CIRT}^2 = D = E \{ (h_q - h)^2 \}. \quad (5)$$

### IV. EXIT-CHART OPTIMIZED CHANNEL QUANTIZATION

In this paper we propose an algorithm, which allows the system to use a different number of quantization bits  $q$  in different symbol intervals. The goal is to minimize the average of  $q$  over a number of symbol intervals, while maintaining a certain target performance. Let us assume for example that there are 100 symbol intervals. The receiver quantizes the ST-CIRTs of 40 symbol intervals using  $q = 2$ -bit quantization and the rest of the ST-CIRTs of 60 symbol intervals using 3-bit quantization. Therefore during the observed 100 symbol intervals, the average number of feedback bits for each sampled ST-CIRT conveying both the magnitude and phase is  $q = 2 \cdot 0.4 + 3 \cdot 0.6 = 2.6$ . The question is now, how to determine the required number of quantization bits  $q$  for the sampled ST-CIRTs.

In order to resolve this design dilemma, we adopt the design concept of irregular convolution codes [11] and aim to minimize the average value of  $q$ , while assuming that an open EXIT-tunnel is still attainable for the iterative system at a given  $E_b/N_0$  values. More explicitly, we exploit the fact that similarly to having different channel SNRs, the different amount of ST-CIRT

quantization noise imposed by varying  $q$  allows us to shape the EXIT-curve of the inner component of our DL-SDMA system. Assume that there are  $N_{ts}$  symbol intervals in an observed transmission block and we employ  $N_Q$  different number of quantization bits to quantize the ST-CIRT. For example, we have  $q = \{2, 3, 4, 5\}$  for  $N_Q = 4$ . The ST-CIRTs in the segment of  $\alpha_j N_{ts}$  symbol intervals will be quantized by using a specific number of quantization bits  $q$ , where  $\alpha_j$  is a weight, controlling the size of each segment. Then the weighting coefficient  $\alpha_j$  has to satisfy:

$$1 = \sum_{j=1}^{N_Q} \alpha_j, \quad \bar{q} = \sum_{j=1}^{N_Q} \alpha_j q, \quad \text{and } \alpha_j \in [0, 1], \forall j. \quad (6)$$

where  $\bar{q}$  is an averaged value over the observed transmission block.

According to [11], the corresponding EXIT function  $T_I(I_{in})$ , which characterizes the inner decoder's EXIT-curve in the system, is given by

$$T_I(I_{in}) = \sum_{j=1}^{N_Q} \alpha_j T_q(I_{in}), \quad (7)$$

where  $T_q(I_{in})$  denotes the EXIT function, when the ST-CIRTs are quantized by using  $q$ -bit channel quantization.

Observe that this algorithm provides a framework for managing the ST-CIRT quantization at the DL receivers and their UL transmitter counterparts by using different number of quantization bits  $q$  for feeding the ST-CIRTs back to the BS. This design principle may also be applied for different types of channel quantizers, namely to uniform, nonuniform, scalar or vector channel quantization. Again, we refer to the proposed algorithm as the EXIT-Chart Optimized Channel Quantizer (ECO-CQ). For the sake of simplicity, we demonstrate this EXIT-chart based optimization procedure in the context of the scalar NUQ, which has been introduced in Section III.

## V. SYSTEM MODEL

We illustrate the system models of the iterative DL-SDMA using conventional CQ and the proposed ECO-CQ. Assume that our system equips  $M$  transmit antennas at BS for supporting  $K$  MSs while each MS employs  $N_k$  receive antennas. We denote the  $(N_k \times M)$ -element channel matrix by  $\mathbf{H}^{(k)}$ , which is constituted by the sampled flat-fading channel impulse responses of each Antenna Element (AE) experienced by the  $k$ -th user. The elements  $[\mathbf{H}^{(k)}]_{i,j}$ , where we have  $1 \leq i \leq N_k$  and  $1 \leq j \leq M$ , are i.i.d complex Gaussian random variables with distribution  $\mathcal{CN}(0, 1)$ .

### A. Iterative DL-SDMA Systems Using Conventional CQ

Based on the framework of the iterative DL-SDMA system of [4], we depicted the structure of the iterative DL-SDMA system using a conventional CQ in Figure 2. The source bits are encoded by the channel encoder as well as the unite-rate precoder (URC) [4] and are mapped to the modulated symbols. Let  $\mathbf{s}^{(k)} \in \mathbb{C}^{L_k \times 1}$  be a complex-valued column vector, which denotes the data symbol vector to be transmitted to the  $k$ -th MS, while  $L_k$  represents the number of independent data symbols contained in  $\mathbf{s}^{(k)}$ , which is defined as  $L_k = M - \sum_{j=1, j \neq k}^K N_k$  [4]. Furthermore, we utilize the MUT-STP matrix  $\mathbf{T}^{(k)} \in \mathbb{C}^{M \times L_k}$  of [4], which was designed for the sake of eliminating the MUI by exploiting the knowledge of channel state information at transmitter, as detailed in [6]. In this paper, we assume that  $\mathbf{T}^{(k)}$  is generated based on the quantized ST-CIRT fed back from the DL receivers, which is indicated by the notation  $\mathbf{T}^{(k)}(\mathbf{H}_q)$ , as shown in Figure 2. After the processing of the MUT-STP, the  $K$  DL signals transmitted to  $K$  the MSs will be superimposed and transmitted by the  $M$  transmit antennas.

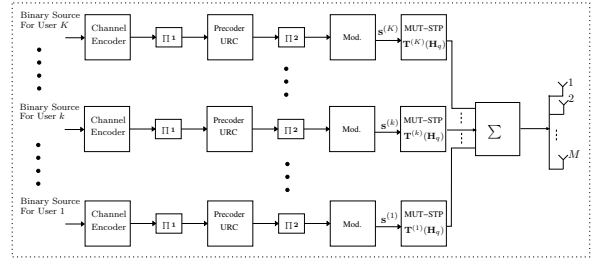

Fig. 2. The structure of the BS transmitter in the iterative DL-SDMA system using conventional CQ

Figure 3 depicts the structure of the MS receiver in the iterative DL-SDMA system using conventional CQ. As seen in Figure 3, the Minimum Mean Squared Error (MMSE) aided SDMA detector constitutes the first stage of the receiver. The iterative decoding process is carried out between MMSE detector, URC decoder and channel decoder as illustrated in Figure 3<sup>1</sup>.

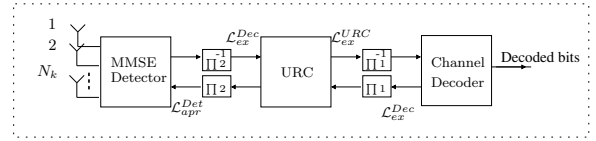

Fig. 3. The structure of the MS receiver in the iterative DL-SDMA system using conventional CQ

Let  $\mathbf{r}^{(k)}$  and  $\mathbf{n}^{(k)}$  be the  $N_k$ -element received signal vector and  $N_k$ -element noise vector associated with the  $k$ -th MS, respectively. If the MUT-STP matrix  $\mathbf{T}^{(k)}$  is generated based on perfect ST-CIRTs, the MUI can be perfectly eliminated. The received signal vector associated with the  $k$ -th MS can be expressed in the following form

$$\mathbf{r}^{(k)} = \mathbf{H}^{(k)} \mathbf{T}^{(k)} \mathbf{s}^{(k)} + \mathbf{n}^{(k)}, \quad (8)$$

where the  $(N_k \times L_k)$ -dimensional matrix  $\mathbf{H}^{(k)} \mathbf{T}^{(k)}$  characterizes the *effective channel* corresponding to the  $k$ -th MS.

Naturally, when the MUT-STP matrix  $\mathbf{T}^{(k)}$  is generated based on imperfect ST-CIRT, the system becomes unable to entirely eliminate the MUI and hence the resultant residual MUI contaminates the received signal of the  $k$ -th MS according to

$$\mathbf{r}^{(k)} = \mathbf{H}^{(k)} \mathbf{T}^{(k)} \mathbf{s}^{(k)} + \sum_{i=1, i \neq k}^K \mathbf{H}^{(k)} \mathbf{T}^{(i)} \mathbf{s}^{(i)} + \mathbf{n}^{(k)}, \quad (9)$$

where the second term of Equation 9 represents the experienced MUI.

### B. Iterative DL-SDMA Systems Using ECO-CQ

Certain structural modifications are required by the iterative DL-SDMA system, when it employs an ECO-CQ. Let us utilize four conventional CQs having different number of quantization bits, namely  $q = 2, 3, 4$  and 5, to construct an ECO-CQ. As illustrated in Figure 4, the data bits encoded by the channel encoder will be partitioned into four segments corresponding to the weighting coefficient vector of  $\boldsymbol{\alpha} = [\alpha_1, \alpha_2, \alpha_3, \alpha_4]$ . Each of the four segments of the channel-encoded bits will also be encoded by the URC encoder of Figure 4 before the modulation stage. For example, for a coding block containing  $L$  encoded bits, the  $j$ -th URC encoder encodes  $\alpha_j L$  bits. Assuming that  $N_{bps}$  bits per modulated symbol are used for transmission, we have a total of  $\alpha_j L / N_{bps}$  transmitted symbols generated by

<sup>1</sup> $\mathcal{L}_{ex}^{URC}$  denotes the extrinsic information, expressed by using the value of the Log Likelihood Ratio (LLR) [1], provided by URC. Similarly,  $\mathcal{L}_{ex}^{Dec}$  is the extrinsic information generated by the channel decoder.  $\mathcal{L}_{apr}^{Dec}$  denotes the *a priori* information provided by the detector.

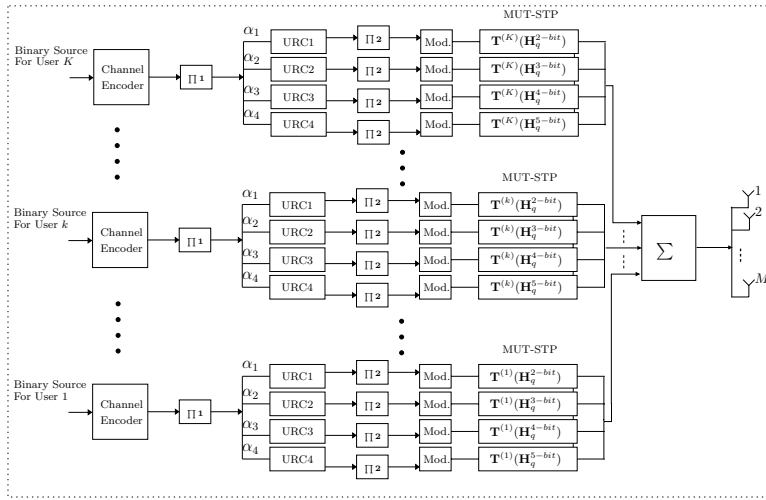

Fig. 4. The structure of the BS's transmitter in the iterative DL-SDMA system using ECO-CQ

the  $j$ -th modulator of 4. Accordingly, as illustrated in Figure 4, the MUT-STP matrix  $T^{(k)}$  will be generated by using the ST-CIRTs, which were quantized using four different number of quantization bits per ST-CIRT coefficient for the four segments of transmitted symbols. The MUT-STP matrix  $T^{(k)}$  generated by the  $q$ -bit quantized ST-CIRTs is denoted by  $T^{(k)}(\mathbf{H}_q^{q\text{-bit}})$ , as shown in Figure 4.

Figure 5 shows the structure of the iterative DL-SDMA using ECO-CQ. First, the received signal will be partitioned into four segments. Accordingly, for each segment of the received signals, the MMSE detector will generate the soft-bits as the input of the URC decoder. The four segments of the extrinsic information bits generated by the URC decoder will become the *a priori* information bits of the channel decoder of Figure 5. As the iterative decoding process is carried out, the extrinsic information bits of the channel decoder will be partitioned into four segments again in order to construct four segments of *a priori* bits of the URC decoder. The four-segment output of the URC decoder will then be forwarded to the MMSE detector for the next iteration of the decoding process.

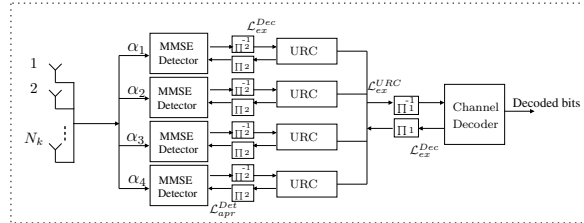

Fig. 5. The structure of the MS receiver in the iterative DL-SDMA system using ECO-CQ

Again, the specific partitioning of the bits or symbols into segments is carried out according to Equation 7, where the transfer functions represent the four segments of soft-bits, i.e. Log Likelihood Ratios (LLR).

## VI. EXIT CHART ANALYSIS

In the following discussions, we provide the EXIT chart analysis of our iterative DL-SDMA systems using conventional CQs and the proposed ECO-CQs.

### A. Iterative DL-SDMA Systems Using Conventional CQ

Figure 6 illustrates the EXIT chart of the iterative DL-SDMA systems using the conventional CQs in conjunction with different number of quantization bits,  $q$ , which is ranging from  $q = 2, 3, 4$

to 5. Observe that by reducing the number of quantization bits, the inner EXIT-curves, which characterizes the MMSE detector and URC-decoder represented inner systems, are getting closer to the outer EXIT-curve, which characterizes the employed RSC channel decoder, until the open tunnel disappears between them. Based on this EXIT chart, we expect that the system will suffer from a high BER, when using 2-bit CQ at  $E_b/N_0 = 6dB$ . On the other hand, the system using a 5-bit CQ performs close to the one benefiting from perfect ST-CIRT.

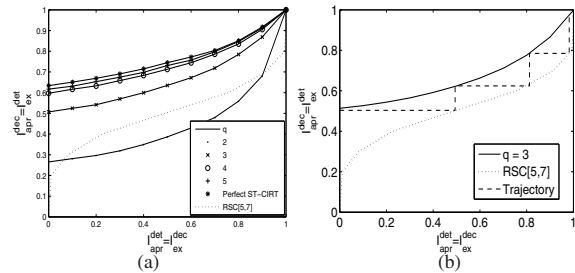

Fig. 6. EXIT chart analysis of the iterative DL-SDMA system using a  $q$ -bit conventional CQ, where  $q$  is ranging from 2, 3, 4 to 5. The systems are operated at  $E_b/N_0 = 6dB$ . (a) shows the inner EXIT-curve of the iterative DL-SDMA system using conventional CQ. (b) shows the recorded iterative decoding trajectory of the iterative DL-SDMA system using conventional CQ. A rate-0.5 RSC[5,7] channel coder is employed by the system. The channel model was an uncorrelated flat-fading MIMO channel and the parameters of Table 1 were used.

TABLE I  
SYSTEM PARAMETERS

Channel Encoder	rate-0.5 RSC code
Interleaver length	$10^5$ bits
Modulation	4QAM
Number of users	$K = 3$
Number of transmit antennas	$M = 6$
Dimension of transmitted signal vector of each user	$L_k = 2$ , for $k = 1, 2, 3$ .
Number of receive antennas of each MS	$N_k = 2$ , for $k = 1, 2, 3$ .

### B. Iterative DL-SDMA Systems Using ECO-CQ

In Figure 6, we found that the systems using 2-bit CQ are unable to maintain an open EXIT-tunnel for  $E_b/N_0 = 6dB$ . Therefore, in order to assist the system in maintaining an open EXIT-tunnel at  $E_b/N_0 = 6dB$ , we have to increase the number of quantization bits to  $q = 3$ . However, the EXIT-tunnel of the systems using 3-bit CQ is rather wide. With the aid of the proposed algorithm of Section IV, and given a certain level of  $E_b/N_0$ , we will be able to design the system for maintaining



a narrow but still open EXIT-tunnel using an average of less than  $q = 3$ -bit accuracy quantization. According to Equation 6, we can design ECO-CQ having a low value of  $q$  corresponding to the weighting vector  $\alpha$ . Figure 7(a) shows the EXIT-curves of the iterative DL-SDMA system using ECO-CQ and  $q = 2.6$  as well as  $\alpha = [0.4, 0.6, 0, 0]$ , namely that 40% ST-CIRTS in a transmission block were quantized by 2-bit CQ, while 60% ST-CIRTS were quantized with 3-bit CQ. In this way, we reduce the number of bits to be fed back to the transmitters. In this example, we reduced 0.4 bits feedback of each sampled ST-CIRT for both the magnitude and phase parts, which means we reduce 0.13%(0.4/3) overall feedback-rate.

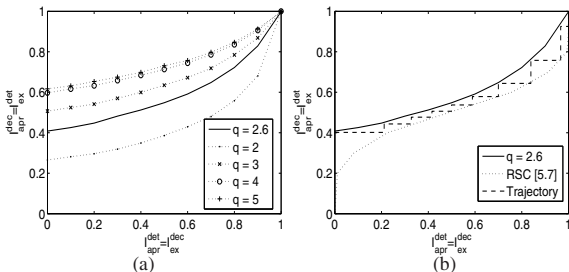

Fig. 7. EXIT chart analysis of the iterative DL-SDMA system using ECO-CQ in conjunction with  $q = 2.6$  and  $\alpha = [0.4, 0.6, 0, 0]$  at  $E_b/N_0 = 6$  dB. (a) shows the inner EXIT-curve of the iterative DL-SDMA system using ECO-CQ. (b) shows the recorded iterative decoding trajectory of the iterative DL-SDMA system using ECO-CQ. A rate-0.5 RSC[5,7] channel coder is employed for the system. The channel model was an uncorrelated flat-fading MIMO channel and the parameters of Table I were used.

## VII. PERFORMANCE RESULTS

In the section we provide the corresponding BER performance results. The system parameters used are listed in Table I.

Figure 8 characterizes the BER performance of the iterative DL-SDMA system using a conventional CQ and an ECO-CQ. As illustrated in Figure 8, the iterative DL-SDMA systems using ECO-CQ in conjunction with  $q = 2.6$  bits are capable of obtaining an infinitesimally low BER lower at  $E_b/N_0 = 6$  dB. This confirms the prediction of the EXIT chart analysis seen in Figure 7. Upon increasing  $q$ , we are able to achieve an infinitesimally low BER at lower  $E_b/N_0$ . The BER performance of system using perfect ST-CIRT is also provided in Figure 8 as a benchmark. Figure 8 shows the performance of the system using 5-bits CQ is close to the one benefiting from perfect ST-CIRT. Compared to  $q = 5$ , we are able to reduce 1.5 quantization bits per ST-CIRT sample for both magnitude and phase quantization by using ECO-CQ in conjunction with  $q = 3.5$  at an  $E_b/N_0$  loss of less than 0.5 dB.

In Table II, we characterized the ECO-CQ aided iterative DL-SDMA system using the minimum required number of quantization bits  $q$  for both magnitude and phase of each ST-CIRT coefficient, while maintaining a target BER of  $10^{-5}$ . In order to attain the target BER, the system employing conventional CQ may be required to use a 3-bit CQ to quantize the ST-CIRT, when we have  $E_b/N_0 \geq 4$  dB, as illustrated in Figure 8. On the other hand, the ECO-CQ aided system may use a reduced value of  $q$  to quantize the ST-CIRT, such as 2.9, 2.8, 2.7, and 2.6, while maintaining the same target BER. The corresponding reduced feedback overheads are listed in Table II.

## VIII. CONCLUSIONS

In this paper, we proposed an algorithm referred to as ECO-CQ, which assists the system in maintaining the minimum feedback overhead, while ensuring that an open EXIT-tunnel is still attainable. The corresponding reduced feedback overheads are listed in Table II. For example, the ECO-CQ aided iterative

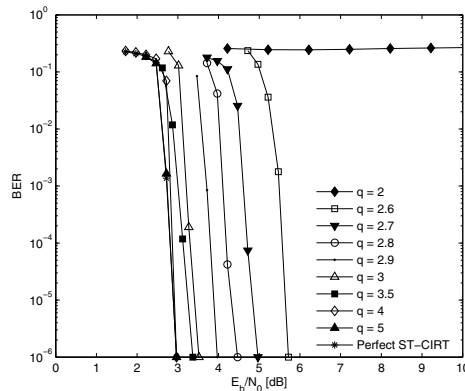

Fig. 8. BER performance of the iterative DL-SDMA systems using ECO-CQ in conjunction with different values of  $q$ , where the  $\alpha$  of the ECO-CQ in associated with  $q = 2.6, 2.7, 2.8, 2.9$  and  $3.5$  are  $\alpha = [0.4, 0.6, 0, 0], [0.3, 0.7, 0, 0], [0.2, 0.8, 0, 0], [0.1, 0.9, 0, 0]$  and  $[0, 0.5, 0.5, 0]$ , respectively. The number of decoding iteration is  $I = 12$ . A rate-0.5 RSC[5,7] channel coder is employed for the system. The channel model was a flat-fading MIMO channel in associated with the normalized Doppler frequency  $f_d = 0.001$  and the parameters of Table I were used.

TABLE II

REDUCED FEEDBACK OVERHEAD OF THE ECO-CQ AIDED ITERATIVE DL-SDMA SYSTEMS (EXTRACTED FROM FIGURE 8)

	$E_b/N_0$ [dB]	3.5	4.5	5	6
Conv. CQ	Min. required $q$ -bit	3	3	3	3
	Norm. FB overhead $\Lambda$	1.8%	1.8%	1.8%	1.8%
ECO-CQ	Min. required $q$ -bit	3	2.8	2.7	2.6
	Norm. FB overhead $\Lambda$	1.8%	1.68%	1.62%	1.56%
Norm. overhead reduction ratio $R_A$		0	6.7%	10%	13%

DL-SDMA system associated with  $q = 2.7$  achieves a 10% normalized overhead reduction at  $E_b/N_0 = 5$  dB.

## REFERENCES

- [1] L. Hanzo and M. Münster and B-J. Choi and T. Keller, *OFDM and MC-CDMA for broadband multi-user communications, WLANs and Broadcasting*. John Wiley and IEEE press, 2003.
- [2] P. Vandenameele, L. van der Perre, and M. Engels, *Space division multiple access for wireless local area networks*. Kluwer, 2001.
- [3] R. Irmer, "Multiuser transmission in code division multiple access mobile communications systems," Ph.D. dissertation, Technische Universität Dresden, 2005.
- [4] C.-Y. Wei, J. Akhtman, S. X. Ng, and L. Hanzo, "Iterative near-maximum-likelihood detection in rank-deficient downlink SDMA systems," *IEEE Transactions on Vehicular Technology*, vol. 57, pp. 653 – 657, Jan 2008.
- [5] S. ten Brink, "Designing iterative decoding schemes with the extrinsic information transfer chart," *AEU International Journal of Electronics Communications*, vol. 55, pp. 389 – 398, 2000.
- [6] L.-U. Choi and R. Murch, "A transmit preprocessing technique for multiuser MIMO systems using a decomposition approach," *IEEE Transactions on Wireless Communications*, vol. 3, no. 1, pp. 20 – 24, 2004.
- [7] W. Liu, L. L. Yang, and L. Hanzo, "Channel prediction aided multiuser transmission in SDMA," in *Vehicular Technology Conference, 2008. VTC Spring 2008, IEEE*, May 2008, pp. 1330–1334.
- [8] J. Proakis, *Digital communications*. McGraw-Hill, 1995.
- [9] A. Gersho and R. M. Gray, *Vector Quantization and Signal Compression*. Boston/Dordrecht/London: Kluwer Academic Publishers, 1991.
- [10] L. Hanzo, F. Somerville, and J. Woodard, *Voice and Audio Compression for Wireless Communications*. IEEE Press and John Wiley, 2007.
- [11] M. Tüchler and J. Hagenauer, "EXIT charts of irregular codes," in *In Proceedings of Conference Information Sciences and Systems, Princeton [CDROM], NJ, USA, March, 2002*.