

AN AGENT BASED APPROACH TO MODELING DESIGN TEAMS

Richard Crowder¹, Helen Hughes², Yee W Sim¹ and Mark Robinson².

¹ School of Electronics and Computer Science, University of Southampton, Southampton UK.

² Leeds University Business School, Leeds, UK.

ABSTRACT

It is well recognized that an effective design process is contingent on the joint optimization of both the social and technical aspects of such an activity. Thus interactions between individual designers, within integrated product teams, and the nature of design tasks, all have a significant impact upon how well a design task can be performed, and hence the quality of the resultant product and the time in which it can be delivered. In order for organizations to gain a full understanding of interactions within integrated product teams, we propose the use of multi-agent systems to develop computer models of the behaviors and cognitions of team members, and to explore the applicability of different agent-theoretic approaches that could augment current understanding of team practices. In this paper we describe an ongoing research project which aims to model integrated product teams. We discuss the background and rationale for this work, and explore the antecedents and consequences of individual and team variables. A multi-agent system for modeling integrated product teams has been developed, and the initial results are presented.

Keywords: Multi-Agent Systems, Modeling, Teamwork in design

1. INTRODUCTION

The demands of the global market place are forcing engineers and engineering teams to design and develop better products in ever decreasing time periods. In such environments, designers are required to communicate and collaborate with colleagues across departmental and company boundaries [1]. It has become common practice for many organizations to form multi-disciplinary integrated product teams (IPTs) to support the move to concurrent engineering practices [2]. Socio-Technical Systems Theory (STST) maintains that the success of any project is dependent not only on the technology employed by the organization, or the technical ability of the individual design engineers, but also on the collaboration, communication and cooperation between individuals and their interactions with the working processes [3].

It is widely understood that when a new design problem emerges, the designer's knowledge related to their previous experiences of similar problems is applied. Adler [4] commented that more experienced designers are able to connect a resolved design problem to a new problem quicker and easier than less experienced designers. To resolve a design issue, a designer will draw on their informal network of contacts, personal experiences and memory. Previous research has shown that approximately 20% of the designer's time is spent searching for and absorbing information, of which 40% will be from personal resources and networks. This occurs even when information is available from elsewhere in the organization [5, 6]. In addition, it is well recognized that the use of past experiences and previously acquired knowledge, either from the designer's own experiences or from resources within their organization, is an important part of the design process. It has been estimated that 90% of industrial design activity is based on variant design [7], while during a redesign activity up to 70% of the information is taken from previous solutions [8]. Empirical research has shown that engineers spend substantial amounts of time giving and receiving information. For instance, an observation-based study of design engineers had found that 33% of work time was spent in such processes, of which 12% was spent on acquiring or being given information, another 8% on providing information, 4% on activities related to information transfer, and the remaining 9% on attending meetings [9].

In order to study these interactions within large manufacturing companies, we are using multi-agent based simulations of human social behavior. This not only facilitates an analysis of the resultant team dynamics, but also allows the authors to investigate the applicability of agent-theoretic approaches to such problem. This paper discusses the problem domain and the rationale for this research, together with the resultant multi-agent model. Firstly, we undertook a detailed study of existing IPTs in order to determine the variables and associated parameters for the model, as discussed in Section 4. In Section 5 we present a modeling environment that permits a design team to be modeled from a social viewpoint, as opposed to approaches that consider an iterative design process [10]. It should be recognized that in our approach of modeling IPTs, we do not yield absolute information (e.g. this task will take X hours to complete), but rather to look at the sensitivity of the internal and external drivers of the design process (e.g. what will be the impact on the process of changing the composition of a team or communication policy). Finally in Section 6, we discuss the initial results from modeling a number of scenarios, and consider the challenges associated with the development and validation of the final model.

2. RELATED WORK

Several approaches to modeling engineering design teams and IPTs have been reported in the literature to date [11-15]. The GRAI-Engineering approach models the structure of the coordinated decision and design activities, and is based on systems, hierarchy and activity theory; however, it does not consider social behavior within teams [11].

TEAKS [15] is reported to take a multi-agent systems approach for modeling the performance of a design team, and hence facilitates optimization. The variables within TEAKS are based on the PECS (*Physical condition, Emotive state, Cognitive capabilities and Social status*) reference model of human behavior [16]. Another related approach in calculating design team performance is reported by O'Donnell [12], by extending the IDEF \emptyset model [17].

Team working has been extensively studied by psychologists [18-20]. A published review of the research literature [21] showed that team working offers organizations many advantages over individual working and was associated with organizational efficiency and improved quality. However, there is widespread acceptance that in order to achieve this, effective team-working must be cultivated by organizations [18]. A team's performance depends on a variety of factors and processes concerning the characteristics of the individual team members (e.g. motivations, ability) and also the way the team interacts and works together to achieve the team's goals (e.g. communication processes, trust, shared understanding). As organizations continue to recognize the benefits of team working bring to their business, researchers are becoming increasingly interested in understanding how team members might interact with each other. There is also a growing interest in the processes involved in team working, and a number of theoretical approaches have been proposed and tested, which attempt to explain how teams function [19].

The communication between the designers themselves and with external resources is a crucial factor in determining the effectiveness of the design process. Communication structure has largely been studied in the context of communication networks, or social networks, which refer to the "pattern of open channels of communication, or informal exchange, between members of a particular group" [22]. It is also possible to consider the centrality of an entire social network, to determine, for example, whether it is centralized or decentralized. Furthermore, different levels of centrality have been shown to influence problem-solving performance in teams. Although centralized networks are best for simple problems, more difficult problems are best addressed through decentralized networks with more communication channels [23].

The work by Patrashkova-Volzdoska et al. [24], together with our current research suggest that effective communication is even more important in IPTs compared to conventional work teams, due to the multi-disciplinary nature of the work. More specifically, IPTs are composed of individuals from a number of diverse technical and non-technical backgrounds [2]. Such functional diversity also results in diverse knowledge bases and value systems, making the issue of effective communication important. Indeed, communication is seen as a fundamental component of engineering work in a multi-disciplinary environment, involving as it does the integration of specialized knowledge across different functions [25]. It is widely recognized that engineering design involves situations of distributed cognition, such that the knowledge required to achieve particular objectives is distributed among several people, thereby necessitating communication [26]. Furthermore, the research conducted

by Lloyd and Deasley [27] has suggested that engineering design is very much a social process involving negotiating, bargaining, discussion and explanation.

Related to effective communication is the extent to which designers share their understanding (i.e. have shared mental models). Shared mental models are crucial to effective team working. The purpose of IPTs is to share knowledge and information in order that the overall design will have advantages over previous designs. To properly utilize the knowledge of team members, and in turn use it to develop solutions to new problems or create new knowledge, team members must know who knows what, and interact with each other in order to combine this knowledge [28]. As Wenger [29] noted, knowledge utilization is fundamentally a social process. However, team working requires not only that team members communicate and collaborate with each other, but also that they share a mutual view on design, task and supporting teams. Shared understanding is related to communication, as effective communication is a precursor to the development of a shared understanding of the design problem. Shared understanding is also linked with team motivation. Individual design engineers bring with them to a team their own terminology, perspectives or design identities, and these perspectives can be incompatible. For design teams to succeed it is crucial that they pool their resources and perhaps even negotiate a new and different perspective that is accepted by the entire team [30]. Participation and involvement are both strongly correlated with team motivation, as they have strong effects on acceptance and commitment to the team's goals or vision [31].

The psychological literature has made a striking impact on our understanding of team working. However they tended to take a 'social' perspective to the team working system, and so has somewhat neglected the impact of structural team factors, such as those related to the nature of the task itself. As such, it might be considered that the psychological literature fails to consider the more 'technical' aspects of the socio-technical system. Given the characteristics of Multi-Agent Systems [32], they can be seen as a very useful tool for modeling human behavior, since they are able to incorporate social and technical variables. These systems enable us to see how such factors affect behavior through rules built from the bottom-up.

Certainly, the use of multi-agent systems has been explored to support human teams [13], where agents were used to provide support to team members given a time-critical task, by aggregating relevant information from their peers about other members' actions. Likewise, social dynamics have been studied through modeling human and group behavior using multi-agent simulation methods [14]. The agent-based approach can enhance the potential of decentralized computer simulation as a tool for theorizing about social scientific issues, since it facilitates the modeling of artificial societies of autonomous intelligent agents.

3. ORGANIZATIONAL RESEARCH

Following a review of previous research in the fields of psychology, computer modeling and engineering, key independent variables were identified at three levels: *individual* (e.g. competence, goal commitment); *team* (e.g. communication, shared mental models, trust); *task* (e.g. problem solving demand). Furthermore, dependent variables such as time, cost and quality were also identified. A preliminary theoretical framework for the model was then developed, based on hypothesized relationships between variables from the research literature. For example, the hypothesized positive relationship between communication frequency and shared mental model similarity is expected to be influenced, or moderated by the type of media used (e.g. email, telephone, face-to-face). Furthermore, these relationships in turn are expected to be moderated by the equivocality of the information being relayed.

Based on this framework, fieldwork was then undertaken, to enable us to populate the model with 'real' data from IPTs operating within two multi-national engineering organizations. The leaders of 50 engineering teams were first asked to complete a questionnaire about their team and participate in a 30-minute semi-structured interview. Following this, a second 87-item, psychometrically-sound questionnaire was administered to the members of each team, as defined by their team leader in the initial questionnaire. The length of the paper does not permit a detailed presentation of the individual questions. The results were analyzed using conventional statistical analysis techniques such as multiple regression to determine the rules and equations required for the multi-agent model. This information is now being incorporated into the model gradually, thereby enabling the hypothesized relationships proposed in the preliminary theoretical framework to be explored and validated. The complexity of the model will then be gradually increased, whilst ensuring that the required accuracy is

maintained. It is anticipated that further data collection - using interviews and observation - will be conducted within a smaller number of IPTs to enable us to develop, enrich and calibrate the model further.

4. DESIGN TEAM MODELING

Based on our organizational research, we approach the modeling of the design process by dividing the design task into a number of sub-tasks. A sub-task, which is undertaken by a single designer, is defined by its requirements and constraints, while the designer operates within a set of competencies. Hence the completion of the overall task is dependent on the completion of all the constituent sub-task, which in turn is dependent on the requirements of each sub-task and the designer that is allocated to complete it. Considering the design task shown in Figure 1, the global workflow rules can be expressed as follows:

- Sub-task B and C will start after sub-task A is completed.
- Sub-task D will start after task B is completed.
- Sub-task E will start after both sub-tasks C **and** D are completed.

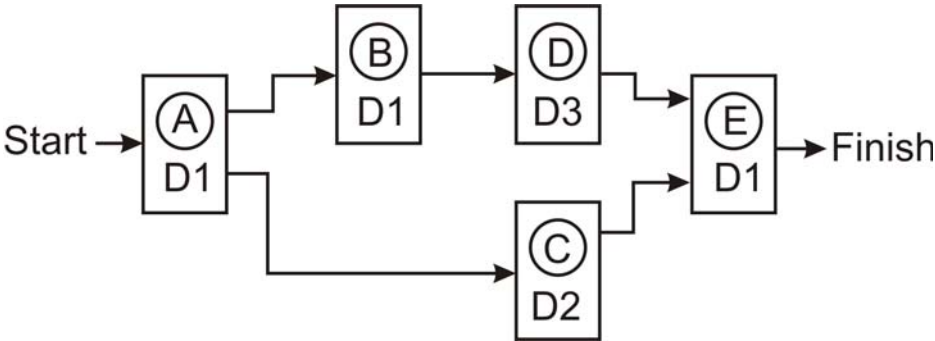

Figure 1: A typical workflow of a design task consisting of five design sub-tasks (A–E) being undertaken by three designers (D1, D2, D3).

4.1 The Designer and Sub-Task Model

The model for the individual design sub-task used in this work is based on the IDEFØ approach [12]. The IDEFØ approach supports the modeling of design activities and their inter-relations, with the focus on performance. As in our approach, IDEFØ does not explicitly represent the elements of performance, and the design process may be seen as the processing of knowledge. Hence although the IDEFØ model only provides a basis; it needs to be further developed in order to provide the capability to model the social aspects of our work.

Figure 2 shows details of the designer and the associated sub-task.

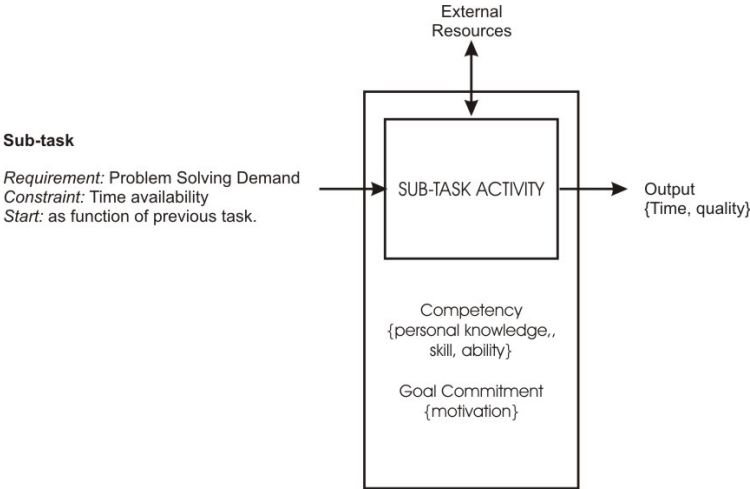

Figure 2: The basic model of a sub-task and its relationship to the designer.

Following our initial studies, we had identified a number of variables that characterize the design sub-task together with their allocated designer. The variables that we currently have incorporated into the model were obtained from the organizational research as discussed in Section 3, and can be summarized as:

1. The sub-task's requirements, including its complexity and other requirements; currently these are combined into a single variable, termed *problem solving demand* (PSD_ind);
2. The designer's technical ability or *competency* (COMP_ind);
3. The designer's commitment in achieving the *set goal* or motivation; (GOAL_ind);
4. As a designer may contribute to more than one design team, the designer's availability as a proportion of the available working time is incorporated into the model;
5. The structure, modality, frequency and content of the communication; the communication model used is discussed later in this section.

The algorithms used within the multi-agent system were derived from the initial organizational research used to compute the time (T) taken to complete the sub-task and the resultant quality Q;

$$T = f\{ PSD_ind, COMP_ind, GOAL_ind \} \quad (1)$$

$$Q = f\{ PSD_ind, COMP_ind, GOAL_ind \} \quad (2)$$

The time provided by equation (1) is the time required to complete the sub-task, and can be used to calculate the overall cost and time to complete a specific design task. The current version of the model also calculates a metric that relates to the quality of the completed task. The quality metric refers to the overall quality of all of the team's work conducted during a particular task and addresses all conceivable outputs

Balancing the relative importance of these variables and their interrelationships within the model, is fundamental to developing a realistic simulation of IPTs. Given the difficulty of accurately quantifying such variables, our initial approach is to use a finite, qualitative set of descriptors such as *very low*, *low*, *medium*, *high* and *very high*. The weightings for each of the variables will be adjusted on the basis of the information collected during the current ongoing phase of the project, together with detailed discussions with our industrial partners.

4.2 The Team Model

As a team, an IPT (by definition) must consist of a least two people, with a maximum of typically around twenty [19]. Figure 3 illustrates a two person simplified IPT working on a single task, and shows all of the elements currently involved within the model, including:

1. The *TaskManager* which has the role of implementing the workflow, which was determined during the initialization of the simulation.
2. The two designers work independently on their sub-tasks. From the initial literature review it is clear that knowledge held by one designer can be supplied to a second designer either as an external resource or as a constraint. The dashed communication path shows this interchange of knowledge as required. The effectiveness of such communication is likely to be influenced by variables such as trust and shared mental models, and we will explore this in our future work.
3. Both designers are able to access an external set of resources, though the communication model.

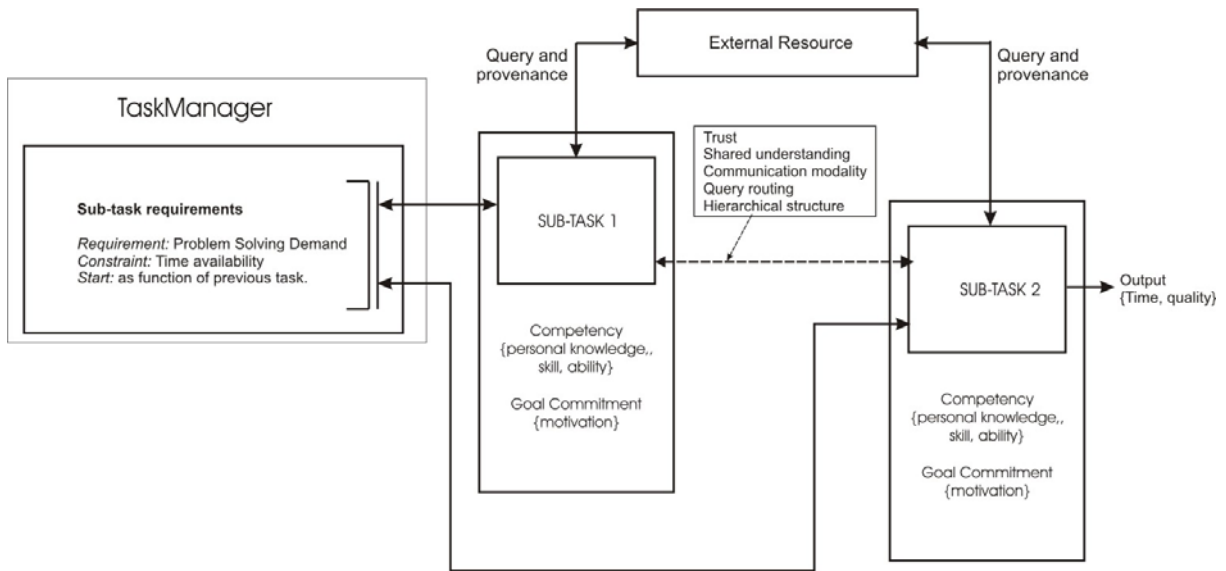

Figure 3. A simplified interaction diagram of an integrated product team, showing two designers working on a single task.

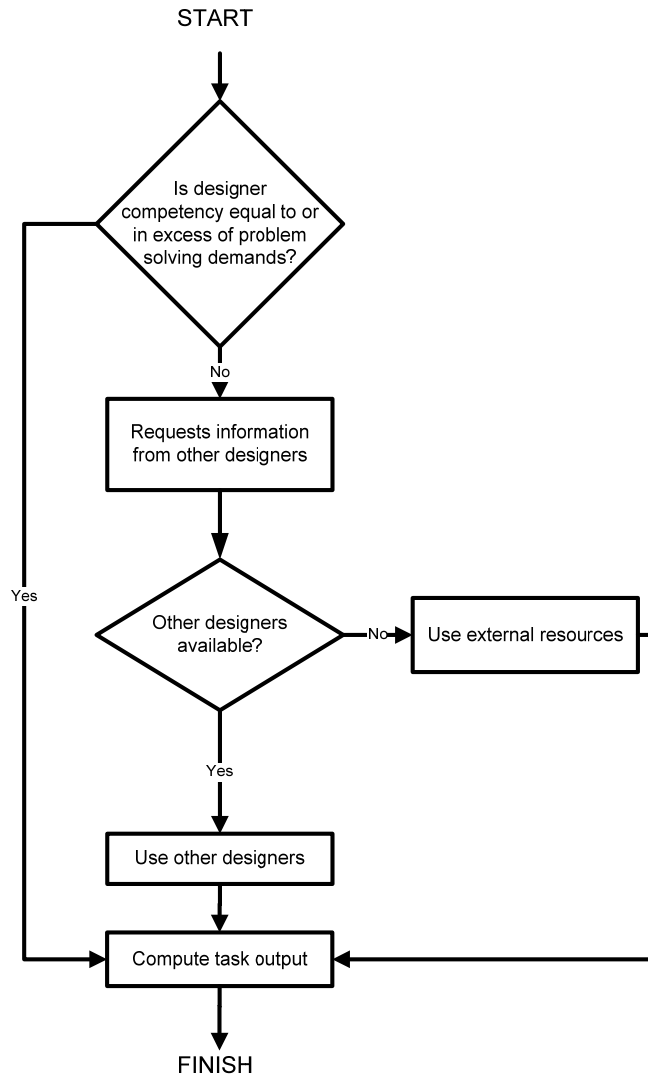

Figure 4: A simplified flow diagram of the current communication model

A communication model was developed so that a designer with insufficient knowledge (expressed as $COMP_ind$) to complete a sub-task can request additional information from a range of sources, i.e. other designers within the IPT or external resources. The basic structure of the model is shown in Figure 4. The response rate of each designer to a request varies and it is currently dependent on the designers' competency level. A designer with higher competency level will typically have a low response rate compared to those with lower competency, the actual values are determined during the initialization of the model. In addition, more knowledge transfer will take place if the competency gap between the designer asking for help and the one responding is larger, the current algorithms used to calculate the time (T_c) taken to acquire the required knowledge is ;

$$T_c = \frac{COMP_ind_{request} - PSD_ind}{\sum_n [COMP_ind_{request} - COMP_ind_{response}]} \quad (3)$$

where PSD_ind is the sub-task's problem solving demand and $COMP_ind_{request}$ is initial competency of the designer undertaking the subtask, communication will be initiated if PSD_ind is greater than $COMP_ind_{request}$. As noted earlier only a number of designers will respond, due to the response rate being less than 100%, those that do will have a competency of $COMP_ind_{response}$. To compute the time the individual response rates are summed over the n designers who can respond. The determined communication time is summed to the value given in equation (1) to give the overall time for the task. However in practice, an individual designer does not spend 100% of their available time undertaking a single task. Hence the model incorporates an *availability* variable, which will moderate the time, $T+T_c$, and allows us to more accurately determine the actual time to complete a task. In the model the computed time is termed effort and gives a measure of the cost of undertaking the design task.

5. CURRENT IMPLEMENTATION

The multi-agent simulation has been implemented using JADE, to model the individual agents, and to facilitate analysis of the team interaction. The current model contains three types of agent, namely *DesignerAgent*, *ResourceAgent*, and *TaskManagerAgent*. The states and behaviors for the individual agents within the current version of the simulation are defined in Table 1. Within the model, each *DesignerAgent* and *ResourceAgent* has three input variables, namely competency, goal commitment and availability, where the values (ranging from very low to very high) of each variable are input by the users at the start of the simulation

Table 1 A Summary of the agents present in the model, together with their state's and behaviors.

Agent	State	Behaviour
<i>DesignerAgent</i>	<ul style="list-style-type: none"> • Competency • Goal Commitment • Availability 	<ul style="list-style-type: none"> ○ Perform task assigned by the TaskManagerAgent. ○ If the DesignerAgent's competency is lower than task complexity, seek help from other DesignerAgents or ResourceAgent ○ May respond to a help request
<i>ResourceAgent</i>	<ul style="list-style-type: none"> • Competency • Goal Commitment • Availability 	<ul style="list-style-type: none"> ○ Always respond to a help request
<i>TaskmanagerAgent</i>	<ul style="list-style-type: none"> • Problem solving demand • Task progress 	<ul style="list-style-type: none"> ○ Assign tasks to DesignerAgents accordingly ○ Keep track of task progress

It should be noted, that as a legacy of the model's developmental process, the model currently uses slightly different terminology for some of the variables relative to the variable labels shown in Table 1. More specifically, in the current model goal commitment is referred to as motivation, and problem solving demand is referred to as complexity. Furthermore, designers' availability is referred to as

commitment in the current model. These inconsistencies are temporary and will be reconciled during future work and in the final version of the model.

The simulation environment has been developed with ease of use in mind; Figure 5 shows the data entry screens for the individual designers and the work flow. In addition a number of pull down menus allow the availability and communication response rates to be set. The output files are available in comma separated variable format, which can be used for subsequent analysis.

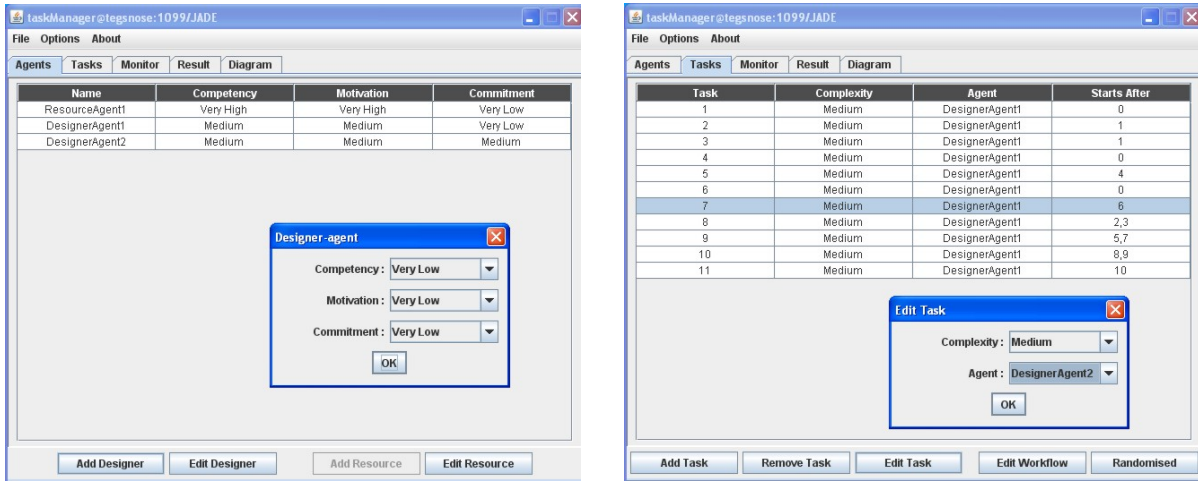

Figure 5: User interface for the simulator, the screen on the left allows the competency, goal commitment (shown as motivation) and availability (shown as commitment) to be entered. The workflow is entered using the screen to the right, where the problem solving demand of the task and the designated designer can be selected

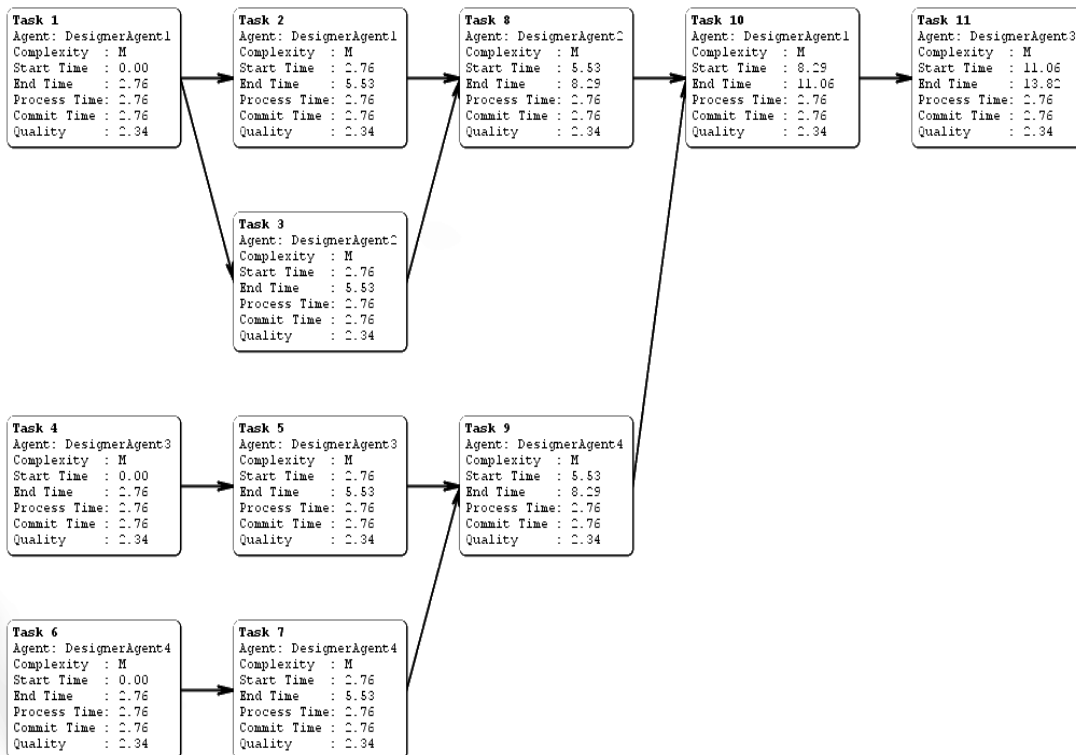

Figure 6: Design task containing 11 subtasks, all of a medium problem solving demand (complexity) – this workflow is referred as the standard task in the paper.

6. SIMULATION RESULTS

In order to provide initial results from the simulation, we have modeled an IPT involved in a design task that involves eleven sub-tasks of equal problem solving demand, as shown in Figure 6. Using this

initial model we can investigate the impact of selecting designers with different levels of variables. As the detailed simulation work is still at an early stage of development, we present two case studies that explore the impact of the number and competency of designers undertaking a design task.

6.1 Number of Designers

Using our standard task, the time and quality of the overall design task was simulated using 1, 2 and 4 designers, the tasks being allocated to minimize the overall design time. The results are shown in Table 2. Both here and in Table 3, effort refers to the time required to complete the task, while the elapsed time equates to calendar time. In Table 2, as expected, as additional designers become involved and start to work in parallel, the actual time decreases, while the effort and quality remain constant. With the standard design, there are effectively four parallel paths and hence only four designers are required to achieve the minimum elapsed time.

Table 2: The effort and time of undertaking the standard design task as a function of the number of designers. All the subtasks have a medium PSD_ind, the designer has medium GOAL_ind and COMP_ind. The designer's availability is 70%.

Number of Designers	Quality	Effort	Elapsed Time
1	25.70	30.36	43.45
2	25.70	30.36	35.55
4	25.70	30.36	19.75

6.2 Changes to the designers' attributes.

In practice an IPT will typically consist of designers with differing abilities. Using the developed system, the impact of varying composition of the team can be easily simulated. Typical results for a number of hypothetical teams are provided in Table 3.

Table 3: The effort and time of undertaking the standard design task as a function of the designer's COMP_ind, with GOAL_ind remaining at medium. Each designer's availability is 70%.

Case	Designer COMP_ind				Quality	Effort	Elapsed Time
	1	2	3	4			
1	M	M	M	M	25.70	30.36	19.75
2	M	VH	VH	M	28.60	27.76	18.29
3	VH	M	M	VH	29.18	27.24	17.37
4	M	VL	VL	M	22.80	34.09	22.67
5	VL	M	M	VL	19.32	58.30	38.52

It can be seen from Table 3 that, using Case 1 as the reference case, the introduction of designers with a very high competence as in Cases 2 and 3 does reduce the effort and actual time, and increases the quality metric. However the actual changes in time are small compared to Cases 4 and 5. In these cases two designers have been introduced with very low competence. The resultant time increases comes from two factors, the longer process time per sub-task and the additional time required to undertaking the communications necessary to bring the individual designer's competence from *very low* to *medium* as required by the problem solving demand. As the response to an information request is random, depending on the preset communication response rates, the values given in the table are the average (mean) over 40 runs, the actual results, showing the variation, as shown in Figure 7.

7. CONCLUDING COMMENTS

It should be recognized that some of the assumptions that have been made in the initial model may not necessarily hold in reality – further analysis of the data collected in the organizational research phase will determine this – but initial feedback from our industrial partners has indicated that they are a good approximation of current practice within their IPTs. Within an open organization, the composition of the team may vary, and thus notions such as commitment to the team's goals need to be considered, as

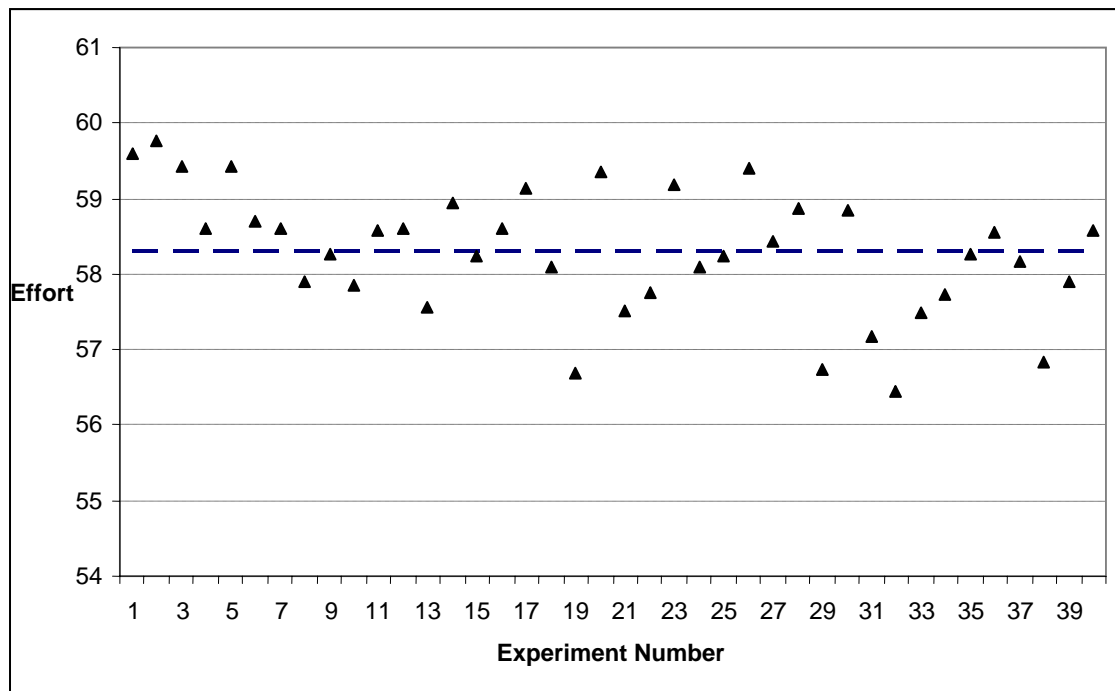

Figure 7: Actual results for Case 5, showing the variation of the effort, due to the random responses from the DesignerAgents to communication requests. The average effort is shown as a dotted line.

well as considering the utility gained by the team in relation to the sum of individual member contributions. In addition, as we are modeling individuals in a business organization, such resources are limited (a co-worker or colleague cannot be found in two places at once), and thus the scheduling of tasks (and the consequential impact of this on the team's performance) should also be considered when performing tasks, as well as responding to defaulted actions or delays [33]. Many of these issues have been addressed in the Multi-Agent Systems literature, and will be incorporated in future versions of the model.

This paper has reported the initial approach to the modeling of IPTs within large engineering organizations. We have based our model on an extension of the IDEFØ functional model. Within this model we have implemented a knowledge–time relationship which is currently considered to be linear, but further work is being carried out to optimize the algorithms within the design activity model. Our approach to modeling IPTs considers both social and technical aspects of the team working system, and the interactions between these factors. We are currently considering the effectiveness with which knowledge is passed between designers as this is likely to be influenced by trust and shared mental models.

The initial feedback from our industrial partners indicates that the approach reported in the paper is a highly realistic approach for modeling team systems. In parallel with the development of the model we will be undertaking further organizational research involving observations of, and interview with our industrial partners, to refine and validate the variables we have identified, and move towards quantifying them.

ACKNOWLEDGMENT

The HIPARSYS project is co-funded by the Technology Strategy Board's Collaborative Research and Development program (www.innovateuk.org) under grant number *TP/3/DSM/6/I/ 16032*. In addition we acknowledge the contribution of our industrial partners, Rolls–Royce and Jaguar Land Rover.

REFERENCES

1. Mountney, S., J. Gao, and S. Wiseall, *A knowledge system to support manufacturing knowledge during preliminary design*. International Journal of Production Research, 2007. **245**(7): p.

- 1521-1537.
2. Fleming, Q. and J. Koppelman, *Integrated project development teams: another fad...or a permanent change?* International Journal of Project Management, 1996. **14**(3): p. 1663-168.
 3. Emery, F. and E. Trist, *Socio-technical Systems*. Management Sciences Models and Techniques. Vol. 2. 1960.
 4. Adler, M., et al., *Conflict resolution strategies for non-hierarchical distributed agents*, in *Distributed Artificial Intelligence*, L. Gasser and M. Huhns, Editors. 1989, Morgan Kaufmann Publishers Inc. p. 139-161.
 5. McMahon, C., A. Lowe, and S. Culley, *Knowledge management in engineering design : personalization and codification*. Journal of Engineering Design, 2004. **15**(4): p. 307-325.
 6. Shadbolt, N. and N. Milton, *From knowledge engineering to knowledge management*. British Journal of Management, 1999. **22**(6): p. 409-423.
 7. Goa, Y., I. Zeid, and T. Bardez, *Characteristics of an effective design plan to support re-use in case-based mechanical design*. Knowledge Based Systems, 1998. **10**: p. 337--350.
 8. Khadilkar, D. and L. Stauffer, *An experimental evaluation of design information reuse during conceptual design*. Journal of Engineering Design, 1996. **7**(4): p. 331-330.
 9. Marsh, A., *The capture and utilisation of experience in engineering design*. 1997, University of Cambridge.
 10. Wynn, D., C. Eckert, and P. Clarkson, *Modelling iteration in engineering design*. 16th International Conference on Engineering Design (ICED'07), 2007: p. 693-694
 11. Girard, P. and G. Doumeings, *GRAI-Engineering: a method to model, design and run engineering design departments*. International Journal of Computer Integrated Manufacturing, 2004. **17**(8): p. 716-732.
 12. O'Donnell, F. and A. Duffy, *Modelling design development performance* International Journal of Operations & Production Management, 2002. **22**(11): p. 1198-1221.
 13. Payne, T.R., et al., *Agent-Based Team Aiding in a Time Critical Task*. HICSS '00: Proceedings of the 33rd Hawaii International Conference on System Sciences-Volume 1, 2000.
 14. Tsvetovat, M. and K.M. Carley, *Modeling Complex Socio-technical Systems using Multi-Agent Simulation Methods*. Kunstliche Intelligenz (Artificial Intelligence Journal), 2004. **Special Issue on Applications of Intelligent Agents**(2).
 15. Martanez-Miranda, J., et al., *TEAKS: Simulation of human performance at work to support team configuration*, in *5th international joint conference on Autonomous Agents and Multiagent Systems*, AAMAS06. 2006.
 16. Schmidt, B., *Modelling of Human Behaviour The PECS Reference Model* 14th European Simulations Symposium, 2002.
 17. Sarkis, J. and L. Lin, *An IDEF 0 functional planning model for the strategic implementation of CIM systems*. International Journal of Computer Integrated Manufacturing, 1994. **7**(2): p. 100-115.
 18. Guzzo, R. and M. Dickinson, *Teams in organizations: recent research on performance and effectiveness*. Annual Review of Psychology, 1996. **47**: p. 307-338.
 19. West, M., K. Borrill, and C. Unsworth, *Team effectiveness in organizations*, in *International Review of Industrial and Organizational Psychology*. 1998, John Wiley & Sons Ltd: Chichester, UK.
 20. West, M., F. Brodbeck, and A. Richter, *Does the 'romance of teams' exist? The effectiveness of teams in expermental and fields settings*. Journal of Occupational and Organizational Psychology, 2004. **4**: p. 476-472.
 21. Applebaum, E. and R. Blatt, *The New American Workplace*. 1994, Ithaca, NY: ILR.
 22. Mullen, B., C. Johnson, and E. Salas, *Effects of communication network structure: Components of positional centrality*. Social Networks, 1991. **13**: p. 169-186.
 23. Shaw, M., *Communication networks*, in *Advances in Experimental Psychology*, L. Berkowitz, Editor. 1964, New York: Academic Press. p. 154-177. .
 24. Patrashkova-Volzdoska, R., et al., *Examining a curvilinear relationship between communication frequency and team performance in cross-functional project teams*. IEEE Transactions on Engineering Management. **50**(3): p. 262-269.
 25. Sonnenwald, D., *Communication roles that support collaboration during the design process*. Design Studies, 1996. **17**: p. 277-301.

26. Busby, J., *Error and distributed cognition in design*. Design Studies, 2001. **22**: p. 233-254.
27. Lloyd, P. and P. Deasley, *Ethnographic description of design networks*. Automation in Construction, 1998. **7**: p. 101-110.
28. Cross, R., S. Borgatti, and A. Parker, *Beyond answers: dimensions of the advice network*. Social Networks, 2001. **23**: p. 215-235.
29. Wegner, D., *Transactive memory: a contemporary analysis of group mind*, in *Theories of Group Behaviour*, B. Mullen and G. Goethals, Editors. 1987, Springer: New York. p. 185-208.
30. Hill, A., et al., *Identifying shared understanding in design using document analysis*, in *DETC01 ASME 2001 Design Engineering Technical Conference and Computers and Information in Engineering Conference*. 2001.
31. O'Leary, K., J. Martocchio, and D. Frink, *A review of the influence of group goals on group performance*. Academy of Management Journal, 1994. **37**(5): p. 1265-1301.
32. Wooldridge, M. and N. Jennings, *Intelligent Agents: Theory and Practice*. The Knowledge Engineering Review, 1995. **10**(2): p. 115-152.
33. Stein, S., T.R. Payne, and N.R. Jennings, *An Effective Strategy for the Flexible Provisioning of Service Workflows* Service-Oriented Computing: Agents, Semantics, and Engineering, 2007: p. 16-30.

Contact: Dr Richard Crowder
Intelligence, Agents, Multimedia
School of Electronics and Computer Science
University of Southampton
Southampton
SO17 1BJ

Richard Crowder is a senior lecturer within the School of Electronics and Computer Science at the University of Southampton. His primary research interests are in the application of information technology to manufacturing industry. During his time at Southampton has led a number of major research projects in this area and collaborated with a large number of major UK manufactures.