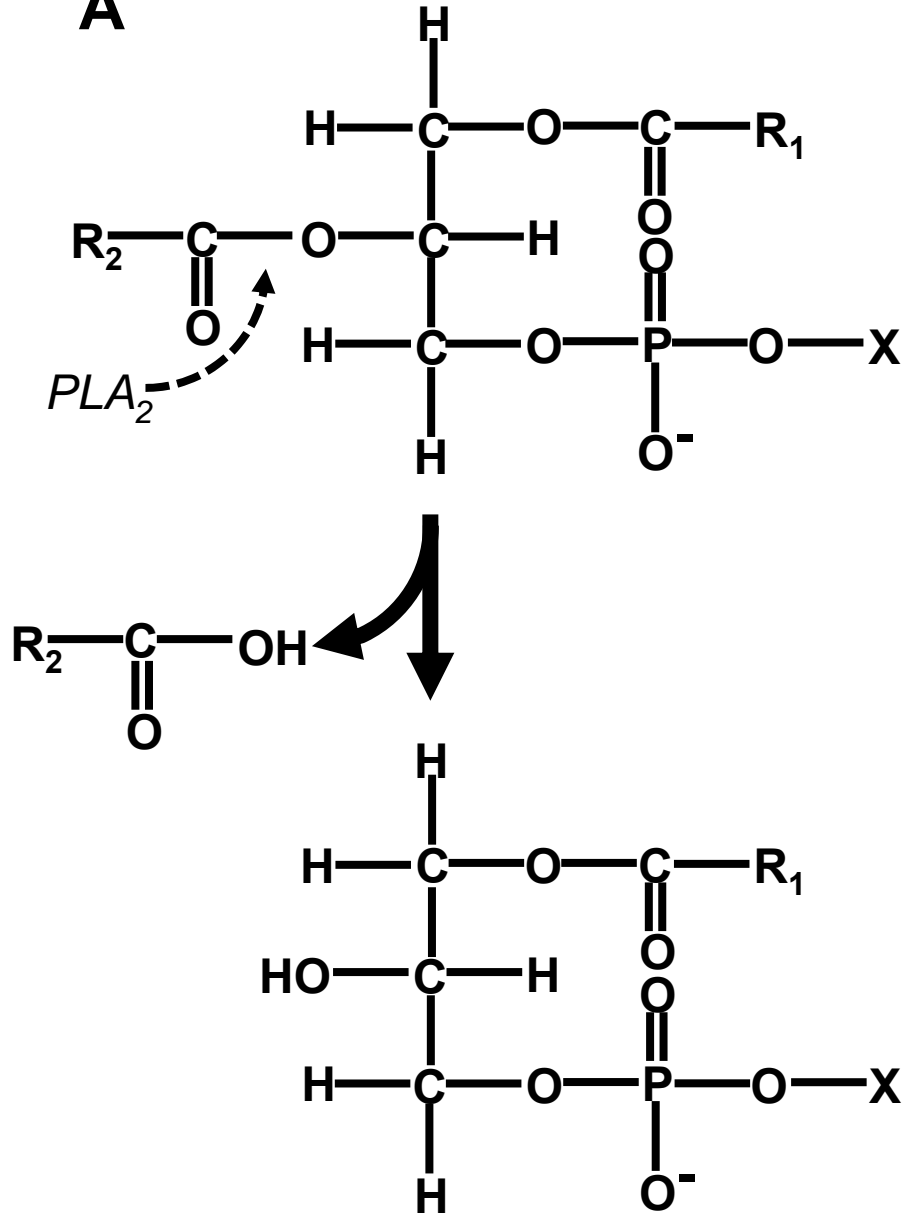

A**B**