

Comments on “A Passive and Wireless Sensor Based on RFID Antenna for Detecting Mechanical Deformation”

Mahmoud Wagih, *Member, IEEE*

Abstract—He et al. proposed a mechanical deformation sensor based on a microstrip patch antenna matched to a radio frequency identification (RFID) integrated circuit (IC). In Fig. 6 in [1], a near-field coupled RFID system was shown, whereas the developed system operated in the far-field region. This comment presents a more representative figure explaining the operation principle of UHF RFID system, supplementing the information in [1].

Index Terms—Sensor, RFID, antenna, mechanical deformation, structural health monitoring, rectifiers.

THE authors He *et al.* proposed an interesting application of Ultrahigh Frequency (UHF) Radio Frequency Identification (RFID)-based sensing in structural health monitoring, using a microstrip antenna matched to a commercial RFID integrated circuit (IC) [1].

The operation principle of an example RFID system was introduced by the authors in Fig. 6 in [1], reproduced in Fig. 1(a). This figure is based on the explanation from the RFID Handbook [2], illustrating the operation of a near-field coupled RFID system, where the information and power transmission between the reader and the tag is shown as the coupled field lines between the coils. While Fig. 6 in [1] showed a coupled RFID system, the system proposed by He *et al.* operates in the uncoupled far-field region, where the information and power are transferred through electromagnetic propagation [3], as in Fig 1(b), as opposed to near-field coupling between coils. Furthermore, Fig 1(a), from [1], shows the rectifier, tuning and charge-pumping capacitors, and the modulating transistor-switch as “off-chip” components. However, the commercially-available IC used in the work includes the power conversion and modulation/demodulation circuitry within the IC “chip”, as shown in the suggested explanation of the operation principle of UHF RFID, in Fig. 1(b) [3], supplementing the figure by He *et al.*, which was based on a coupled near-field system with off-chip components [2].

REFERENCES

- [1] Y. He, M. M. Li, G. C. Wan, and M. S. Tong, “A passive and wireless sensor based on rfid antenna for detecting mechanical deformation,” *IEEE Open Journal of Antennas and Propagation*, vol. 1, pp. 426–434, 2020.
- [2] *Fundamental Operating Principles*. John Wiley & Sons, Ltd, 2010, ch. 3, pp. 43–44. [Online]. Available: <https://onlinelibrary.wiley.com/doi/abs/10.1002/9780470665121.ch3>

The author is with the School of Electronics and Computer science, University of Southampton, Southampton, SO17 1BJ, U.K. (email:mahm1m19@soton.ac.uk).

The author was supported by the UK Engineering and Physical Sciences Research Council (EPSRC) under Grant EP/P010164/1.

Digital Object Identifier: .

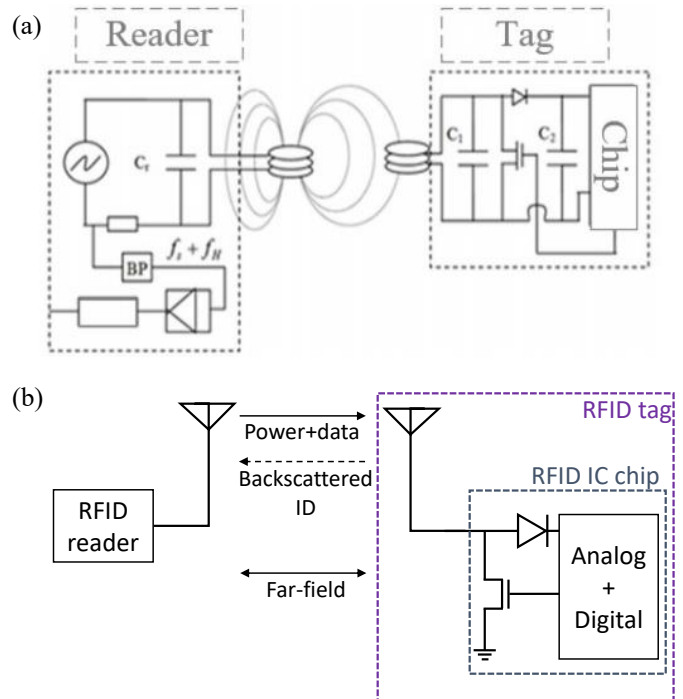

Fig. 1. Operation principle of a UHF RFID system: (a) Figure 6 from [1], showing a near-field coupled RFID system with the RF front-end “off-chip”. (b) the operation principle of a far-field UHF RFID system based on a commercial RFID IC.

- [3] K. Rao, P. Nikitin, and S. Lam, “Antenna design for uhf rfid tags: a review and a practical application,” *IEEE Transactions on Antennas and Propagation*, vol. 53, no. 12, pp. 3870–3876, 2005.