

UNIVERSITY OF SOUTHAMPTON

MESOPOTAMIAN CERAMICS OF THE
THIRD MILLENNIUM BC
WITH ANALYSIS OF POTTERY FROM
ABU SALABIKH, KISH AND UR

H. S. Mynors

Volume 2
Part i

MASTER

**8: THIRD MILLENNIUM MESOPOTAMIAN
CERAMICS: POTTERY CORPUS**

8 **THIRD MILLENNIUM MESOPOTAMIAN CERAMICS: POTTERY CORPUS**

8.1 **INTRODUCTION**

Any examination of a large body of archaeological material is subject to the difficulties of presenting the data in a compact and retrievable form.

Some two thousand nine hundred samples are included in the corpus. Such a considerable bulk and variety of material has necessitated cataloguing the results (see Section 8.2) in order to achieve the requirements of a concise and accessible format. The pottery catalogue constitutes the primary source of information and reference is made to further details provided in a series of additional tabulations which present the classification of vessel types (Table 8.1) and fabrics (Table 8.3) and which record the results of scientific analyses performed on individual samples (Tables 8.5, 8.6 and 8.7).

Chronological distinctions apparent from a combination of vessel type and fabric are most marked in comparisons between ED I and ED III pottery assemblages. Early ED I fabrics often bear a marked resemblance to those common in middle to late Uruk pottery sequences, suggesting the possibility that technological changes observed in fabric types correspond with the chronological distinctions.

A number of middle to late Uruk pottery types from each of the three principal sites being examined (Ur, Abu Salabikh and Kish) have therefore been selected for inclusion in the pottery corpus.

8.2 CERAMIC CLASSIFICATION AND ANALYSIS

8.2.1 Introduction

The classification and analysis of Mesopotamian ceramics principally of the third millennium forms an archive of material from which it is possible to correlate a chronological assessment of pottery types with a classification of the fabrics. This information is presented in a pottery catalogue (Table 8.4) which includes references to the results of analyses conducted on individual samples, incorporating both petrographic and trace element analyses (see Sections 8.3, 8.4 and 8.5).

The catalogue provides the basis both for a regional study of the ceramic industry and for examining trends within the ceramic sequence at an intra-site level. It provides the data from which regional exchange between Babylonia and sites north of the middle Euphrates may be identified, coupled with evidence for long distance trade with sites as far south as the Gulf states (see Sections 4 and 5).

The information includes both published and unpublished material from excavations currently in progress together with samples taken from museum collections. Wherever possible the vessels and sherds have been illustrated (Figs 8.13 - 8.91) and, where excavated material has been published, reference has been made to illustrated forms.

8.2.2. Explanation of the pottery catalogue (Table 8.4)

The catalogue has been divided into twelve columns and a numerical system of coding the columns is intended to enable computerisation of the data if necessary. Where there are no available data for an entry under a specific column this is indicated by a dash. Of the twenty-three sites included in the corpus only three have been extensively sampled: Ur, Kish and Abu Salabikh. The samples from both Ur and Kish are derived from museum collections. All vessels included from Abu Salabikh, however, have been recorded either whilst excavations were in progress or subsequently from site records. Where ceramic assemblages have been examined from museum collections sampling procedures have been subject to the limitations and restrictions discussed in Section 2.2. A more rigorous and

intensive sampling procedure, however, has been applied to the pottery from Abu Salabikh. The advantage of sampling conducted during the progress of excavations has been to produce a considerable body of data which can be quantified according to pottery type, date and fabric. The result of this intra-site study has helped to validate comparisons between pottery types dated on the basis of fabrics, as well as indicating technological differences within a chronological and a typological framework (see section 4).

The pottery samples have been grouped initially according to site, beginning with Ur (the southernmost site from which material has been examined) extending to the sites of the Diyala and Hamrin Basin and ending with Umm an Nar and Hili in the Oman.

The entries for each site have been arranged according to the typological classification (Table 8.1). Thus conical bowls (1.1) are placed before solid-footed goblets (1.3.2.). Each entry is assigned a reference number which is cited in column 1 of the catalogue. The running number from 0001 to 2915 therefore identifies the individual samples.

MUSEUM/SITE NUMBER (COLUMN 2)

The majority of samples come from museum collections. The registered museum number of each pot or sherd is recorded, together with an excavation number if this is traceable, in column 2 of the catalogue. Occasionally there is no recorded accession number and in these circumstances the name of the museum, followed by the abbreviated form 'no acc.', indicates the absence of any registration.

The pottery from Abu Salabikh is catalogued according to batch (level) number and these are arranged in numerical order within each area of the excavation. There are four sub-divisions within the pottery group from Abu Salabikh, namely Main Mound, Area E; Main Mound, Area A; the North-East Mound and the West Mound. Owing to an anomaly in the recording sequence the single exception to this is the pottery from batch number 5212. This is grouped with the pottery batches of the '5000's' from the West Mound although the batch of pottery comes from Area E. The context, however, is duly noted in column 5 and as the pottery is from an ED III context the samples are easily separated from the middle to late Uruk and ED I pottery from the West Mound.

DATE (COLUMN 3)

The material sampled ranges from the late fourth millennium B.C. (middle to late Uruk) through to the end of the third millennium (Akkadian). The majority of the pottery, however, may be dated to the Early Dynastic period. In some instances the date of the context may differ from the typological date of the pottery, particularly when the samples are derived from grave groups. However, a method has been adopted to indicate the date of the sample followed by a question mark when the date is based upon a combination of fabric classification and typological attributes rather than specifically upon the date of the context. Problems occur when there is no information concerning the context of the sample, and in such instances a broad date band is assigned to the sample. For example, the conical bowls from Ur are simply dated to the Early Dynastic period although it has been possible to show chronological trends in rim diameters for conical bowls from Abu Salabikh. The pottery from Ur has proved to be the most difficult to categorise chronologically although the information from the fabric types has helped to narrow the date. The Ur sherds from the Birmingham Museum collections are instructive since many of them exhibit the characteristics of ED I and late Uruk fabrics (see Sample nos. 0303 to 0349).

The use of the term Jamdat Nasr to denote the 'Jamdat Nasr period' defined in terms of pottery by the occurrence of polychrome painted ware, has been avoided in the pottery catalogue. There are no known type-fossils other than the painted ware which can be proved conclusively to belong to the 'Jamdat Nasr period'. Moreover painted ware defined as Jamdat Nasr has not been found at Abu Salabikh which constitutes approximately two thirds of the pottery corpus. Instead, material from sites other than Jamdat Nasr itself is catalogued as either late Uruk or ED I, on the basis of fabric type. For consistency the vessels from Jamdat Nasr which are not painted have been termed ED I on the basis of their fabric classification.

The dating of pottery from Kish and Abu Salabikh has benefited from publication of the excavated material (Mackay 1925, 21-37; 1929, 229-264; McAdam 1983, 53-86; Moorey 1966, 18-51; 1978, 61-75, 89-91, 99-104; Postgate 1978, 77-87; Postgate and Moon 1982, 103-106; Postgate and Moorey 1976, 133-149).

TYPOLOGICAL CLASSIFICATION (COLUMN 4)

The range of material examined has necessitated a detailed and comprehensive system of classification. In the interests of continuity a method has been devised based on typological attributes which serve to identify each individual sample whilst at the same time forming the basis of a systematic arrangement of pottery forms.

Numerical classification is therefore derived from a typology based primarily upon vessel function. This has been arranged in a tabulated form (Table 8.1) accompanied by illustrations of the major typological categories (Figs. 8.1 - 8.12). There are sixteen main types ranging from bowls (Type 1, Figs. 8.1 - 8.4) and jars (Type 2, Figs. 8.5 - 8.10) to body sherds (Table 8.1, Type 8) and bases (Table 8.1, Type 14). A system of decimalisation has been used to indicate the sub-groups within each principal pottery type and these sub-groups are determined by size including, for example, small, medium and large jars. Further sub-divisions have been dictated by rim shape and by decoration.

Many of the entries have more than one typological grouping listed in column 4. Examples include jar rim sherds with both impressed and reserve-slipped decoration. Thus for Sample 1942 the entry under column 4 reads: 2.4.2.5; 8.6.2; 8.9.1.

No attempt has been made to subdivide the upright-handled jars (Table 8.1, Type 9 and Fig. 8.12). It has been widely suggested that differences in decoration of the handles may constitute a dating criterion (Delougaz 1952, 87-91; Moorey 1978, 67; Moon 1982, 45-46) and further that the size and position of handles may be used as additional chronological indicators (Moon 1981, 72-73; Whelan 1981, 96). For the purposes of classification, however, the date entered in column 3 of the catalogue is based upon an examination of the fabric. It has proved more feasible, however, to subdivide the stemmed dishes on the basis of decoration (Table 8.1, Type 10 and Fig. 8.12). Stemmed dish rim and base sherds are usually grouped separately with the exception of stemmed dish sherds which come from a single grave group. For example, Sample 1155 (Table 8.4) is grouped under the subdivision 10.2.1 rather than under 10.7.3 (stemmed dish rims) since it forms part of the same grave group as 1154. One difficulty is that the term 'hollow stand' may apply to sherds from the stems of stemmed dishes, but there is no possibility of isolating such examples and it must be assumed that there is an inherent bias in the quantification of this group of pots.

Whenever possible the catalogue adheres to recognised pottery types from each period. Reference has been made to the comprehensive pottery typology published by Delougaz (1952) and to the pottery types illustrated by Hall and Woolley (1927, pl. 55-61); Mackay (1925, pl. 9-16; 1929, pl. 48-54; 1931, pl. 63-79); Martin (1982, 145-185); McAdam (1983, 53-86); Postgate and Moon (1982, 103-136); and Woolley (1934, pl. 251-267).

It has become customary for excavations to refer to pottery types published in the Diyala sequence (Delougaz 1952) and to vessel types from Ur and al 'Ubaid (Hall and Woolley 1927; Woolley 1934) and from Kish and Jamdat Nasr (Mackay 1925; 1927 and 1934). A concordance of vessel types (Table 8.2) has therefore been prepared which correlates the different terminology used in each publication with the classification of vessel types produced for this pottery corpus.

Sherds

Three major groups of sherds have been included in the typological classification, namely rim sherds, decorated body sherds, and base sherds.

2.4.1.1. Rim sherds

In order to retain continuity, rim sherds have been divided into bowl rim sherds (Type 1.14) and jar rim sherds (Type 2.4) so that they can be attributed to the separate categories of bowls and jars as subdivisions of each main group.

No separate category has been used for the conical bowl rim sherds, solid-footed goblet rim sherds and bevel-rim bowl sherds. Most of these rim sherds are from Abu Salabikh and where complete conical bowls do occur they are usually from grave groups. These are cited in column 2, under their batch number in conjunction with an object number for the grave.

In certain circumstances - where, for example, the base of a jar is missing but the jar can be identified as belonging to a specific group such as small jars (2.1) or spouted jars (5) - the vessel has been listed under the principal group followed by a sub-group giving the rim type.

2.4.1.2 Decorated body sherds (jars) (Type 8)

The decorated body sherds form the largest group in the tabulation of pottery types and many of the sub-divisions are cited in conjunction with whole pots where these are decorated. Where the decorated body sherd is thought to be part of an upright-handled jar the subdivision for the specific type of decoration is recorded below the classification for upright handled jars (Type 9) followed by a question mark.

2.4.1.3. Base sherds (Type 14)

Base sherds have been categorised separately since it is frequently impossible to distinguish between base sherds from bowls and those belonging to jars. String-cut bases, for example, are common to both conical bowls and small jars. If it has been possible to identify string-cut bases from conical bowls and string-cut bases from solid-footed goblets, then the pottery type is noted in brackets next to the base type.

Large jars are frequently manufactured with added ring bases and the presence of an added ring base is noted under the jar type in column 4.

Painted ware

In defining the difference between monochrome and polychrome, it is usual to confine these terms to the consideration of applied paint only. The combination of applied paint with applied slip is clearly equally important. Thus the application of a white slip in combination with painted decoration of a single colour (e.g. red) should be considered as two-toned and therefore polychrome. The distinction between monochrome and polychrome is that the former indicates a pot which is a uniform colour all over and the latter is decorated with a design of one or more colours applied over a slip.

Table 8.1 Third millennium Mesopotamian ceramics: numerical classification of vessel types

- 1 BOWLS
 - 1.1 Conical Bowls
 - 1.2 Transitional bowls
 - 1.2.1 Transitional bowls: cut rim
 - 1.2.2 Transitional bowls: flared rim
 - 1.2.3 Transitional bowls: bevelled rim
 - 1.2.4 Transitional bowls: 'flower-pot'
 - 1.3 Goblets
 - 1.3.1 Footed goblets
 - 1.3.2 Solid-footed goblets
 - 1.3.3 Goblets: other
- BRB Bevel-rim bowl
- 1.4 Cups
 - 1.4.1 Cups: flat base
 - 1.4.2 Cups: round base
 - 1.4.3 Cups: round base, tall
- 1.5 Large bowls: flat base
 - 1.5.1 Platters
 - 1.5.2 Dishes
- 1.6 Round-based bowls/basins
 - 1.6.1 Round-based bowls: small
 - 1.6.2 Round-based bowls: large
- 1.7 Ring-based bowls
 - 1.7.1 Ring-based bowls: large
 - 1.7.2 Ring-based bowls: small
- 1.8 Band-/collar-rim bowls
- 1.9 Sieve bowls
 - 1.9.1 Sieve bowls: flat base
 - 1.9.2 Sieve bowls: round base
 - 1.9.3 'Ladle'
 - 1.9.4 'Strainer'
- 1.10 Moulded bowls
 - 1.10.1 Moulded bowls: round
 - 1.10.2 Moulded bowls: square
- 1.11 Bowls with perforated rim
- 1.12 Grey burnished bowls
- 1.13 Painted bowls
- 1.14 Bowl rim sherds
 - 1.14.1 Bowl sherds: fine; plain rim
 - 1.14.2 Bowl sherds: fine; rolled rim
 - 1.14.3 Bowl sherds: medium; plain rim
 - 1.14.4 Bowl sherds: medium; cut rim

- 1.14.5 Bowl sherds: medium; dished rim
- 1.14.6 Bowl sherds: medium; bevelled/everted rim
- 1.14.7 Bowl sherds: large rims
- 1.14.8 Vertical-sided bowls (see also 1.17)

1.15 Large bowl sherds: coarse ware rims

- 1.15.1-8 Miscellaneous bowl sherds; coarse ware
- 1.15.9 Bowl sherds: coarse ware; shallow dish
- 1.15.10 Bowl sherds: coarse ware rims, decorated rib

1.16 Decoration on bowls

- 1.16.1 Incised, cross-hatched decoration on rim
- 1.16.2 Cable/pie crust decorated bowl rim
- 1.16.3 Cable decorated rib, below rim
- 1.16.4 Notched decoration below rim
- 1.16.5 Wavy-line decoration on rim
- 1.16.6 Ridged (see grosse-blumentopf (GB))

1.17 Spouted bowls

2 JARS

2.1 Small jars

- 2.1.1 Small jars: flat base (string-cut)
 - 2.1.1.1 Small jars: flat base (string-cut), plain rim
 - 2.1.1.1.1 Narrow body
 - 2.1.1.1.2 Short neck, long body
 - 2.1.1.1.3 Short, wide neck, squat body
 - 2.1.1.1.4 Flat, scraped base
 - 2.1.1.1.5 Carinated shoulder
 - 2.1.1.1.7 Ribbed shoulder
 - 2.1.1.2 Small jars with rim: flat base (string-cut)
 - 2.1.1.2.1 Bevelled rims
 - 2.1.1.2.1.1 Bevelled rims, decorated shoulder
 - 2.1.1.2.2 Everted rims
 - 2.1.1.2.2.1 Everted rims, decorated shoulder
 - 2.1.1.2.3 Band rims
 - 2.1.1.2.4 Grooved rims
 - 2.1.1.2.5 Perforated neck/shoulder
 - 2.1.1.2.6 Perforated base
- 2.1.2 Small jars: round base
 - 2.1.2.1 Small jars: round base, plain rim
 - 2.1.2.2 Small jars: round base, bevelled/everted rim
 - 2.1.2.3 Small jars: round base, perforated neck
 - 2.1.2.4 Small jars: round base, perforated
- 2.1.3 Small jars: ring base

2.2 Medium jars

- 2.2.1 Medium jars: round base
 - 2.2.1.1 Medium jars: round base, hole-mouthed
 - 2.2.1.2 Medium jars: round base, plain rim

- 2.2.1.3 Medium jars with rim: round base
- 2.2.1.4 Medium jars: round base, band rim
- 2.2.1.5 Medium jars: round base, perforated
- 2.2.1.6 Medium jars: round base, ribbed and carinated shoulder
- 2.2.1.7 Medium jars: ovoid; narrow neck
- 2.2.1.8 Medium jars: ovoid; wide neck

2.2.2 Medium jars: flat base

- 2.2.2.1 Medium jars: flat base, plain rim
- 2.2.2.2 Medium jars: flat base, round body
- 2.2.2.3 Medium jars: flat base (occasionally string-cut); bevelled/band rim
- 2.2.2.4 Medium jars: flat base, lugged decoration
- 2.2.2.5 Medium jars: flat base, carinated shoulder
- 2.2.2.6 Medium jars: flat base, ribbed at shoulder carination
- 2.2.2.7 Medium jars: flat base, lipped rim
- 2.2.2.8 Medium jars: flat base, perforated neck

2.2.3 Medium jars: ring base

- 2.2.3.1 Medium jars: ring base, plain rim
- 2.2.3.2 Medium jars: ring base, everted rim
- 2.2.3.3 Medium jars: ring base, band rim
- 2.2.3.4 Medium jars: ring base, squat, wide-mouthed
 - 2.2.3.4.1 Medium jars: ring base; squat with perforated rim
- 2.2.3.5 Medium jars: ring base; ribbed, carinated shoulder

2.3 Large jars

2.3.1 Large jars: flat base

- 2.3.1.1 Large jars: flat base, plain rim
- 2.3.1.2 Large jars: flat base, everted rim
- 2.3.1.3 Large jars: flat base (narrow), carinated shoulder

2.3.2 Large jars: convex base

- 2.3.2.1 Large jars: convex base, plain rim
- 2.3.2.2 Large jars: convex base, bevelled rim
- 2.3.2.3 Large jars: convex base, tall neck with everted rim
- 2.3.2.4 Large jars: convex base, band rim
- 2.3.2.5 Large jars: convex base, perforated
- 2.3.2.6 Large jars: convex base, carinated shoulder

2.3.3 Large jars: round base

2.3.3.1 Large ovoid jars

2.3.4 Large jars: ring base

- 2.3.4.1 Large jars: ring base, plain rim
- 2.3.4.2 Large jars: ring base, bevelled, everted or hatchet rim
- 2.3.4.3 Large jars: ring base, collar/band rim
- 2.3.4.4 Large jars: ring base, collar/band rim; wide neck

- 2.3.4.5 Large jars: ring base, ribbed neck
- 2.3.4.6 Large jars: ring base, ribbed shoulder
carination
- 2.3.4.7 Large jars: ring base, rib applied high on
shoulder

2.4 Jar rim sherds

- 2.4.1 Jar rim sherds: hole-mouthed
- 2.4.2 Jar rim sherds: short neck
- 2.4.3 Jar rim sherds: long neck
- 2.4.4 Jar sherds: rolled rim
- 2.4.5 Jar sherds: bevelled rim
- 2.4.6 Jar sherds: collar/band rim
- 2.4.7 Jar sherds: collar/band rim; dished/grooved
- 2.4.8 Jar sherds: flat rim
- 2.4.9 Jar sherds: coarse ware rims

2.5 Jar rims: decorated

- 2.5.1 Jar rims: cable decoration
- 2.5.2 Jar rims: notched decoration (on rim swellings)

2.6 Lids

- 2.6.1 Flat lids
- 2.6.2 Rounded 'lids'/'bungis' (sometimes interpreted as
net-floats)

3 BOTTLES

3.1 Bottles: bevelled rim

3.2 Bottles: everted rim

3.3 Bottles: long neck

- 3.3.1 Bottles: long neck and bevelled rim

3.4 Bottles: carinated shoulder and square body

3.5 Bottles: carinated shoulder

3.6 Bottles: ovoid body

3.7 Bottles: multi-ribbed

4 'DRINKING' BOTTLES

4.1 'Drinking' bottles: double-mouthed

4.2 Pilgrim flasks

5 SPOUTED JARS

5.1 Spouted jars: flat base

- 5.1.1 Small spouted jars: flat base
- 5.1.2 Spouted jars: flat base, round body
- 5.1.3 Spouted jars: flat base, carinated shoulder
- 5.1.4 Spouted jars: flat base, round shoulder, tall
- 5.1.5 Spouted jars: flat base, reserve slip decoration
on shoulder
- 5.1.6 Spouted jars: flat base, tall bottle-neck

- 5.2 Spouted jars: convex base
 - 5.2.1 Spouted jars: convex base, round shoulder, tall (short spout)
 - 5.2.2 Spouted jars: convex base, carinated shoulder
- 5.3 Spouted jars: ring base
 - 5.3.1 Spouted jars: ring base, plain rim
 - 5.3.2 Spouted jars: ring base, bevelled rim
 - 5.3.3 Spouted jars: ring base, carinated shoulder
- 5.4 Spouted jars: pinched ring base
 - 5.4.1 Spouted jars: pinched ring base, flared rim
 - 5.4.2 Spouted jars: pinched ring base, bevelled rim
 - 5.4.3 Spouted jars: pinched ring base, ribbed shoulder carination
- 5.5 Spouted jar: nipple-lug(s) on shoulder
- 5.6 Other spouted jars
- 5.7 Spouted jar sherds: spouts
 - 5.7.1 Short spouts
 - 5.7.2 Long spouts
 - 5.7.3 Conical spouts
 - 5.7.4 Upswept spouts
 - 5.7.5 Downswept/drooping spouts
 - 5.7.6 Spouts attached to rim
 - 5.7.7 Double spouts
 - 5.7.8 Plugged spouts
 - 5.7.9 Double spouts
- 6 WING-LUGGED JARS
 - 6.1 Small wing-lugged jars
 - 6.1.1 Small wing-lugged jars: plain lug
 - 6.1.2 Small wing-lugged jars: perforated lug
 - 6.2 Wing-lugged jars: pinched ring base
 - 6.3 Large wing-lugged jars: added ring base
- 7 FOOTED/CUP-BASED JARS (PEDESTAL JARS)
 - 7.1 Footed jars: plain
 - 7.2 Footed jars decorated with white inlay
- 8 BODY SHERDS (JARS)
 - 8.1 Rouletted decoration
 - 8.2 Gouged decoration
 - 8.3 Combed decoration
 - 8.3.1 Combed decoration: horizontal lines
 - 8.3.2 Combed decoration: diagonal lines
 - 8.3.3 Combed decoration: 'wicker-work'
 - 8.3.4 Combed decoration: horizontal-cross-vertical
 - 8.3.5 Combed decoration: diagonal-cross-vertical

8.4 Lugged jar sherds

- 8.4.1 Lugged jar sherds: lug perforated
 - 8.4.1.1 Small perforated lug
 - 8.4.1.2 Large perforated lug
 - 8.4.1.3 Large perforated lug, cross-hatched decoration on shoulder
 - 8.4.1.4 Vertical rectangular lugs (perforated); triangular notched decoration on shoulder
 - 8.4.1.5 Perforated lug; rib with notched decoration
- 8.4.2 Lugged jars sherds: plain lug
 - 8.4.2.1 Small plain lug(s)/nipple(s)
 - 8.4.2.2 Large, plain, horizontal lug; cross-hatched decoration on shoulder
 - 8.4.2.3 Several vertical lugs
 - 8.4.2.4 Horizontal row of small lugs
 - 8.4.2.5 Multi-lugged (see No. 2829)

8.5 Incised decoration

- 8.5.1 Incised decoration: combed
- 8.5.2 Incised decoration: cross-hatched
- 8.5.3 Incised decoration: flora and/or fauna
- 8.5.4 Incised decoration: herring-bone
- 8.5.5 Incised decoration: 'wavy-line'
- 8.5.6 Incised decoration: 'vertical lines'
- 8.5.7 Incised decoration: cross-hatched triangles
- 8.5.8 Incised decoration: zig-zag

8.6 Impressed decoration

- 8.6.1 Impressed decoration: horizontal row of triangular notches
 - 8.6.1.1 Impressed decoration: more than one row of triangular notches
- 8.6.2 Impressed decoration: finger-nail nicks (pricked)
 - 8.6.2.1 Impressed decoration: more than one row of finger-nail nicks (pricked)
- 8.6.3 Impressed decoration: vertical downstrokes (probably made with fingers)
- 8.6.4 Impressed decoration: zig-zag, rocker pattern
- 8.6.5 Impressed circles
- 8.6.6 Reed impressed decoration
- 8.6.7 Impressed decoration: horizontal row of lozenge shapes (rouletted)
- 8.6.8 Cable-impressed decoration: horizontal
- 8.6.9 Impressed decoration: herring-bone (see also 8.10)

8.7 Cut ware

- 8.7.1 Cut ware: ribbed with cross-hatched decoration and perforated lug
- 8.7.2 Cut ware with incised, cross-hatched decoration
- 8.7.3 Cut ware: fenestrated

- 8.8 Striated/grooved decoration (Tab-rim jars)
 - 8.8.1 Horizontal striated/grooved decoration
 - 8.8.2 Vertical striated/grooved decoration
 - 8.8.3 Horizontal-cross-vertical grooved decoration
 - 8.8.4 Horizontal grooves just above and/or below shoulder carination
- 8.9 Reserve-slipped decoration (on jar shoulders)
 - 8.9.1 Diagonal reserve slip
 - 8.9.2 Horizontal reserve slip
 - 8.9.3 Single, slipped, horizontal band
 - 8.9.4 Diagonal-cross-horizontal reserve slip
 - 8.9.5 Vertical reserve slip (see also 8.8.2)
 - 8.9.6 Alternate bands of horizontal and vertical reserve slip
- 8.10 Leaf-motif (herring-bone pattern, see 8.6.9)
- 8.11 Plain ribs (applied)
 - 8.11.1 Single plain rib on shoulder carination
 - 8.11.2 Several plain ribs on shoulder
 - 8.11.3 Lugs/tabs on plain rib
- 8.12 Decorated ribs: notched/nicked
 - 8.12.1 Single rib with notched/nicked decoration
 - 8.12.2 Several ribs with notched/nicked decoration
 - 8.12.3 Single rib with notched decoration; perforated at intervals
- 8.13 Decorated ribs: cable/pie crust
 - 8.13.1 Narrow cable rib ('fine' ware)
 - 8.13.2 Wide cable rib
 - 8.13.3 Cable rib: twisted/corded decoration
 - 8.13.4 Cable rib: vestigial
 - 8.13.5 Several cable ribs: vestigial
- 8.14 Cable rib: perforated body
- 8.15 'Well-type': combed, wavy-line decoration
- 8.16 Decorated coarse ware (large jars)
 - 8.16.1 Coarse ware: single plain rib
 - 8.16.1.1 Coarse ware: several plain ribs
 - 8.16.2 Coarse ware: single cable rib
 - 8.16.2.1 Coarse ware: several cable ribs (suggests decoration representing a harness of ropes)
 - 8.16.3 Coarse ware: incised decoration
 - 8.16.4 Coarse ware: lugged
 - 8.16.5 Coarse ware: perforated lugs
 - 8.16.6 Coarse ware: perforated
- 8.17 Burnished
 - 8.17.1 Grey burnished
 - 8.17.2 Pink burnished
 - 8.17.3 Red burnished
 - 8.17.4 Cream/white slip: burnished

- 8.17.5 Pattern-burnished: cross-hatching
- 8.17.6 Burnished inside vessel only
- 8.18 Handles
 - 8.18.1 Strap handles
 - 8.18.1.1 Strap handles: twisted ('barley-sugar' pattern)
 - 8.18.1.2 Strap handles: grooved
 - 8.18.2 'Flap-pot' handles
 - 8.18.3 Incised handles
 - 8.18.4 Anthropomorphic handles
- 8.19 Lipped
- 8.20 Carinated jar shoulders
- 8.21 Perforated jar shoulders
- 8.22 Miscellaneous sherds
- 9 UPRIGHT-HANDLED JARS
- 9.1 Upright-handled jar handles
- 10 STEMMED DISHES
- 10.1 Stemmed dishes: plain
 - 10.1.1 Stemmed dishes: plain with perforated stem
 - 10.1.2 Stemmed dishes: notched ribs and perforated, fenestrated stem
- 10.2 Stemmed dishes: incised, geometric decoration
 - 10.2.1 Stemmed dishes: incised, geometric decoration; ribbed and/or perforated
 - 10.2.2 Stemmed dishes: incised, geometric decoration; ribbed
 - 10.2.3 Stemmed dishes: incised, geometric decoration; fenestrated
- 10.3 Stemmed dishes: incised decoration; flora
 - 10.3.1 Stemmed dishes: fenestrated, incised decoration; flora
- 10.4 Stemmed dishes: incised decoration; flora, architecture and female attributes
- 10.5 Stemmed dishes: incised decoration; flora, fauna, architecture and/or female attributes
- 10.6 Stemmed dishes: plastic decoration added
- 10.7 Stemmed dish rims
 - 10.7.1 Stemmed dish rims: plain
 - 10.7.2 Stemmed dish rims: notched rib
 - 10.7.3 Stemmed dish rims: notched rib and 'wavy-line' decoration
 - 10.7.4 Stemmed dish rims: notched rim and 'wavy-line' decoration
 - 10.7.5 Stemmed dish rims: rouletted decoration

- 10.8 Stemmed dish bases
 - 10.8.1 Stemmed dish bases: plain
 - 10.8.2 Stemmed dish bases: ribbed
 - 10.8.3 Stemmed dish bases: perforated
 - 10.8.4 Stemmed dish bases: incised
 - 10.8.5 Stemmed dish bases: incised and perforated
 - 10.8.6 Stemmed dish bases: ribbed
 - 10.8.7 Stemmed dish bases: incised, ribbed, perforated
- 10.9 Stemmed dishes: coarse ware
- 11 HOLLOW STANDS
 - 11.1 Small hollow stands ('wash-stand')
 - 11.2 Large hollow stands: plain
 - 11.3 Hollow stands: ribbed
 - 11.4 Hollow stands: ribbed and fenestrated
 - 11.5 Hollow stands: ribbed and incised
 - 11.6 Hollow stands: ribbed, incised and fenestrated
 - 11.7 Hollow stands: ribbed, incised, fenestrated and perforated
 - 11.8 Hollow stands: cut ware
 - 11.9 Lipped stands
 - 11.10 Hollow stands with internal, applied, horizontal ribs
- 12 MINIATURES
 - 12.1 Miniatures: bowl/goblet
 - 12.1.1 Miniature bowl rim: perforated
 - 12.2 Miniatures: cup
 - 12.2.1 Miniature horn cup: rim perforated
 - 12.3 Miniatures: 'bag-pot' or 'thumb-pot'
 - 12.3.1 'Thumb-pot' with perforated tabs
 - 12.4 Miniatures: jars
 - 12.4.1 Miniature jar with perforated neck
 - 12.4.2 Miniature jar with perforated shoulder-tabs
 - 12.5 Miniature stand: perforated
 - 12.6 Miniatures: sherds
- 13 PAINTED WARE (BODY SHERDS)
 - 13.1 Painted ware: monochrome
 - 13.1.1 Monochrome: red-scarlet
 - 13.1.2 Monochrome: black
 - 13.1.3 Monochrome: purple-plum
 - 13.1.4 Monochrome: dark red
 - 13.1.5 Monochrome: red-orange

13.2 Painted ware: polychrome

- 13.2.1 Polychrome: red on white slip
- 13.2.2 Polychrome: black on white slip
- 13.2.3 Polychrome: red and black on white slip
- 13.2.4 Polychrome: purple on white slip
 - 13.2.4.1 Polychrome: purple and red on white slip
- 13.2.5 Polychrome: red cross-hatched on cream slip
- 13.2.6 Polychrome: black cross-hatched on white slip
- 13.2.7 Polychrome: purple cross-hatched on white slip
- 13.2.8 Polychrome: brown on white slip
- 13.2.9 Polychrome: black zig-zag on white slip
- 13.2.10 Polychrome: red and brown on white slip
- 13.2.11 Polychrome: red and purple on white slip

13.3 Bitumen-coated wares

- 13.3.1 Bitumen-coated outside
- 13.3.2 Bitumen-coated inside

14 BASES

14.1 Flat bases

- 14.1.1 Flat bases: string-cut (conical bowls: 1.1)
- 14.1.1 Flat bases: string-cut (transitional bowls: 1.2)
- 14.1.1 Flat bases: string-cut (footed goblets: 1.3.1)
- 14.1.1 Flat bases: string-cut (solid-footed goblets: 1.3.2)
- 14.1.1 Flat bases: string-cut (other)
- 14.1.2 Flat or slightly convex bases (frequently scraped)
- 14.1.3 Flat or slightly convex bases: perforated
- 14.1.4 Convex bases
- 14.1.5 Flat bases: coarse ware

14.2 Round/ovoid bases

- 14.2.1 Round bases: coarse ware

14.3 Ring bases

- 14.3.1 Ring bases: pinched
 - 14.3.1.1 Ring bases: pinched to form pie crust pattern
- 14.3.2 Ring bases: low
- 14.3.3 Ring bases: high
- 14.3.4 Ring bases: added
 - 14.3.4.1 Large ring bases: added
- 14.3.5 Ring bases: coarse ware

15 COARSE WARE BODY SHERDS

16 CERAMIC OBJECTS

THIRD MILLENNIUM MESOPOTAMIAN CERAMICS

Classification of vessel types: 1 (Bowls)

Conical bowls (1-1)

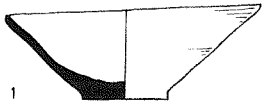

1

Transitional bowls (1-2)

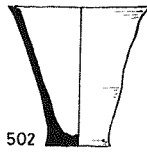

502

Goblets (1-3)



449

Bevel-rim bowls (BRB)

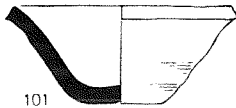

101

Large bowls (1-5-18)

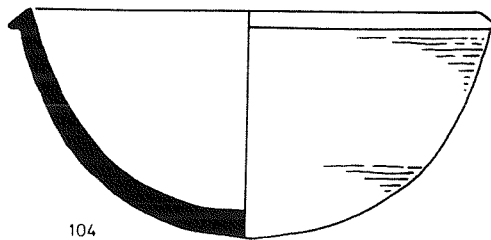

104

Cups (1-4)



2587

Moulded bowls (1-10)



2601

Bowls with perforated rim (1-11)

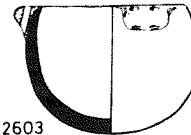

2603

Sieve bowls (1-9)



111

Grey burnished bowls (1-12)

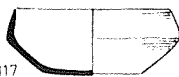

117

Painted bowls (1-13)



2607

0 2 ins
0 5 cm

Fig. 8.1 Third millennium Mesopotamian ceramics. Classification of vessel types: 1 (Bowls) (1)

THIRD MILLENNIUM MESOPOTAMIAN CERAMICS
Classification of vessel types: 2 (Bowl rim sherds)

Transitional bowls (1·2)



1·2·1

1·2·2

1·2·3

1·2·4

Fine, plain rim (1·14·1)

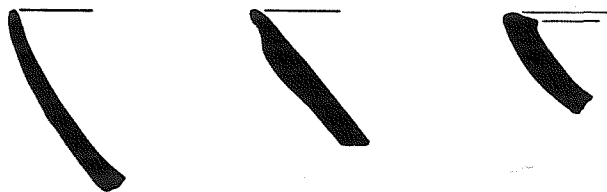

1·14·1·1

1·14·1·2

1·14·1·3

Fine, rolled rim (1·14·2)



1·14·2·1

1·14·2·2

1·14·2·2

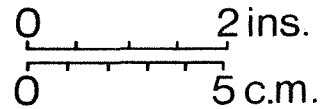

Medium, plain rim (1·14·3)

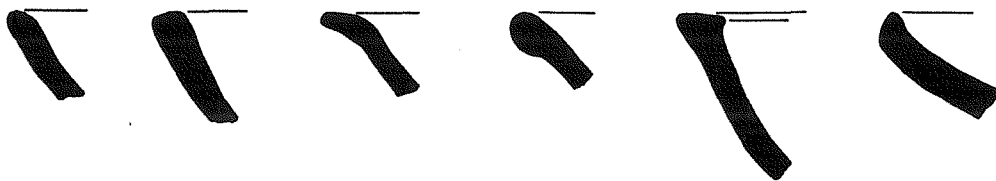

1·14·3·1

1·14·3·2

1·14·3·3

1·14·3·4

1·14·3·5

1·14·3·6

Medium, cut rim (1·14·4)



1·14·4

Fig. 8.2 Third millennium Mesopotamian ceramics. Classification of vessel types: 2 (Bowl rim sherds) (1/2)

THIRD MILLENNIUM MESOPOTAMIAN CERAMICS
Classification of vessel types: 3 (Bowl rim sherds)

Medium, dished rim (1·14·5)

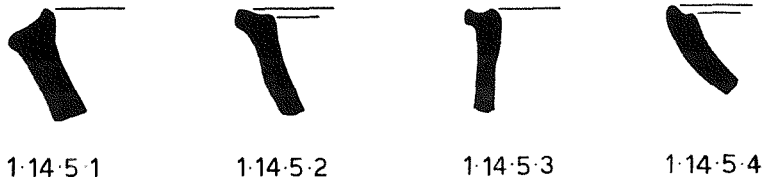

Medium, bevelled/everted rim (1·14·6)

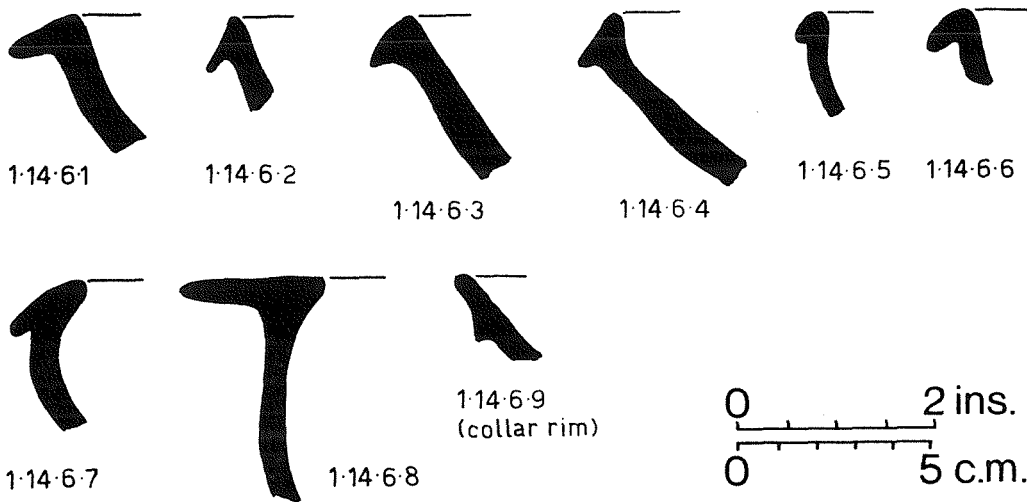

Large rims (1·14·7)

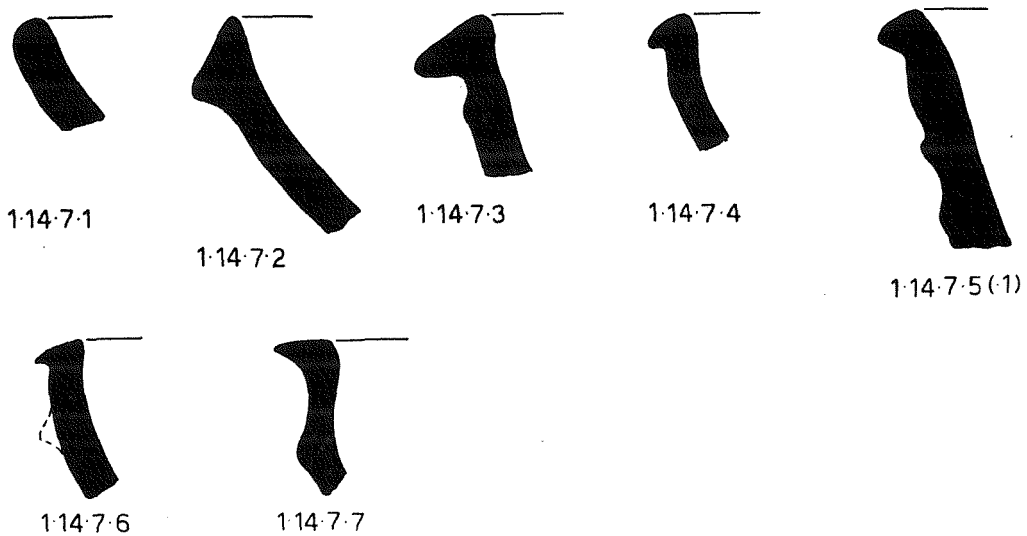
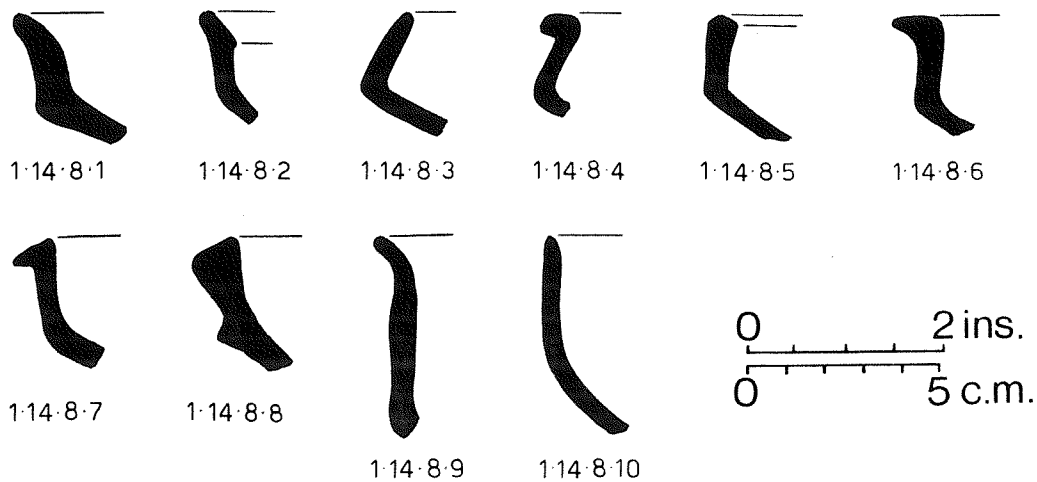

Fig. 8.3 Third millennium Mesopotamian ceramics. Classification of vessel types: 3 (Bowl rim sherds) ($\frac{1}{2}$)

THIRD MILLENNIUM MESOPOTAMIAN CERAMICS
Classification of vessel types: 4 (Bowl rim sherds)

Vertical-sided bowls (1·14·8)



Large coarse ware bowl sherds (1·15)

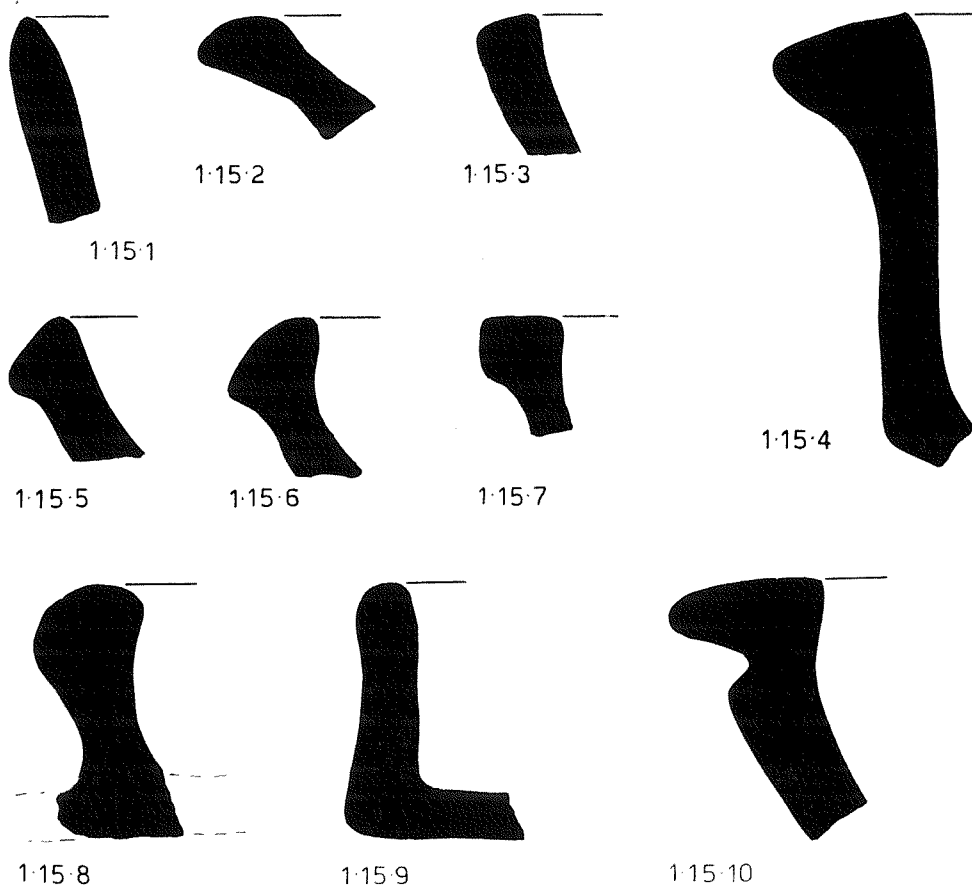

Fig. 8.4 Third millennium Mesopotamian ceramics. Classification of vessel types: 4 (Bowl rim sherds) ($\frac{1}{2}$)

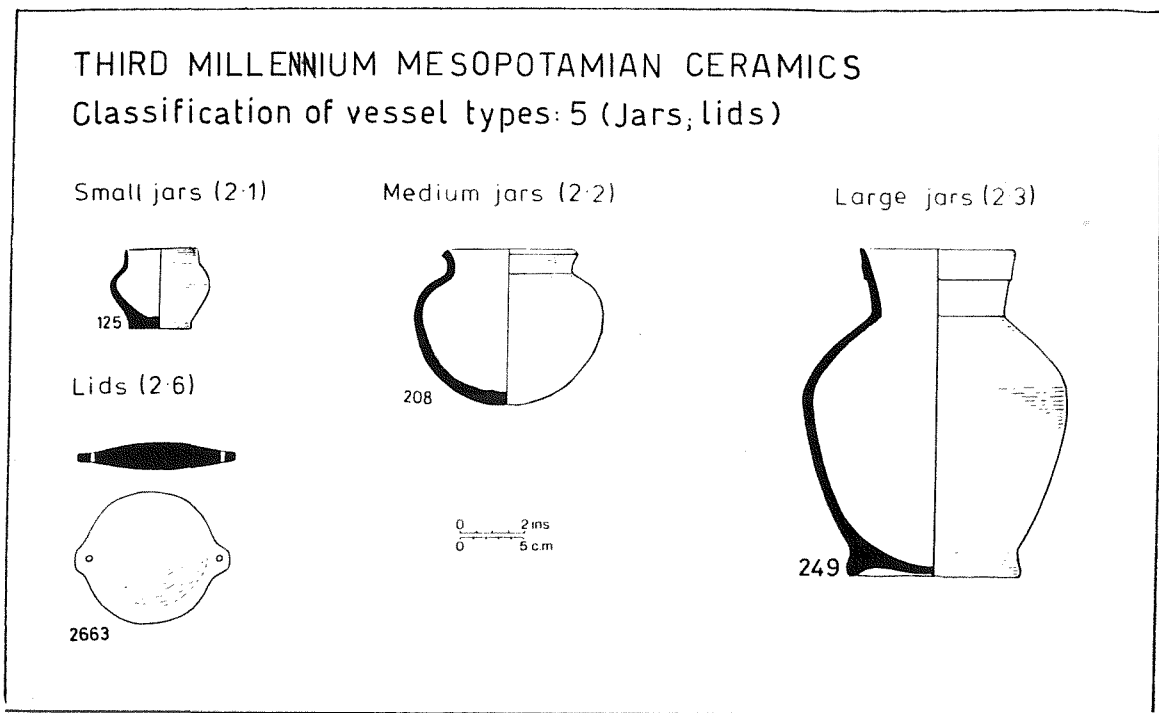
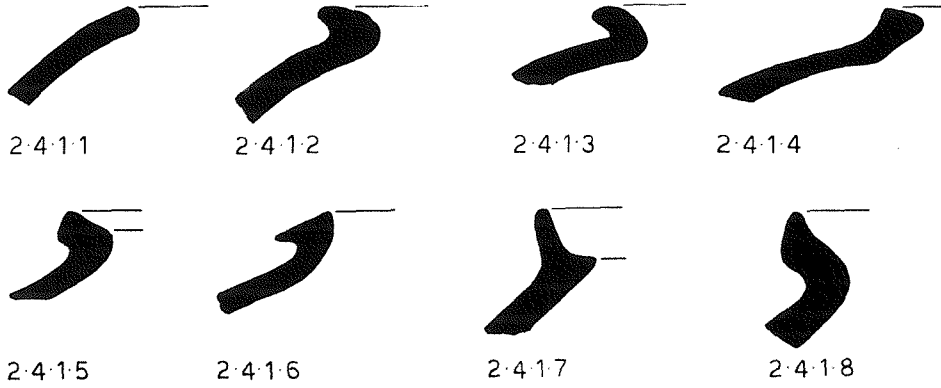

Fig. 8.5 Third millennium Mesopotamian ceramics. Classification of vessel types: 5 (Jars; lids) ($\frac{1}{4}$)

THIRD MILLENNIUM MESOPOTAMIAN CERAMICS
Classification of vessel types: 6 (Jar rim sherds)

Hole-mouthed jar rims (2.4.1)



Short neck jar rims (2.4.2)

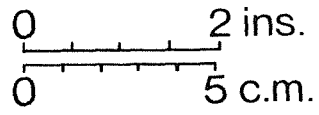
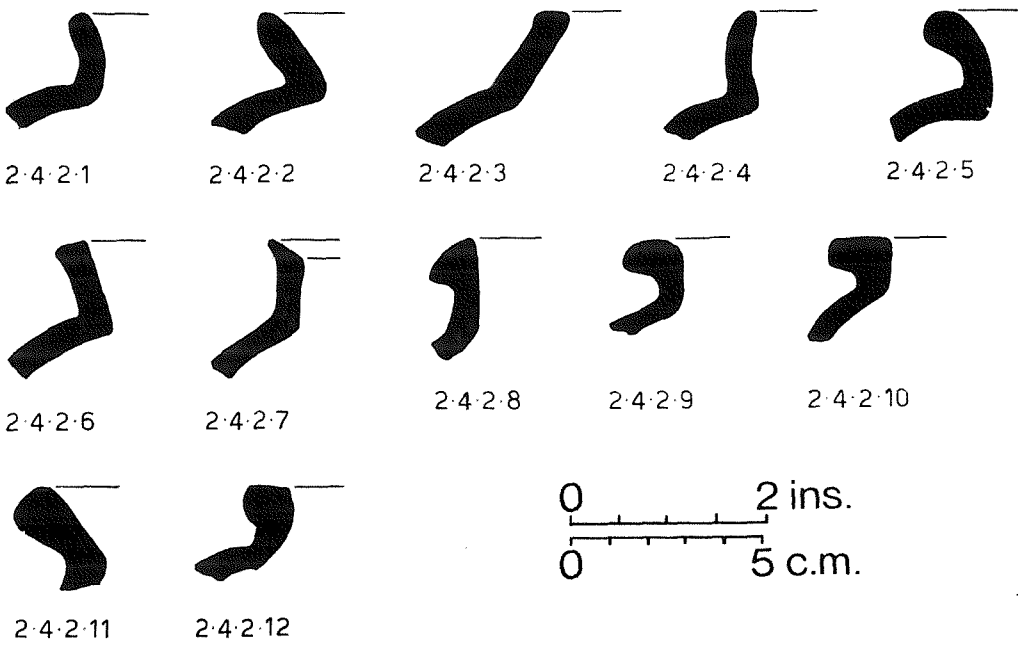

Fig. 8.6 Third millennium Mesopotamian ceramics. Classification of vessel types: 6 (Jar rim sherds) ($\frac{1}{2}$)

THIRD MILLENNIUM MESOPOTAMIAN CERAMICS
Classification of vessel types: 7 (Jar rim sherds)

Long neck jar rims (2·4·3)



2·4·3·1



2·4·3·2

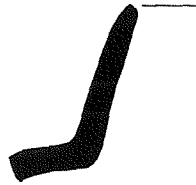

2·4·3·3



2·4·3·4

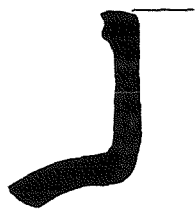

2·4·3·5



2·4·3·6



2·4·3·7

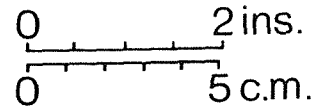

Rolled rims (2·4·4)

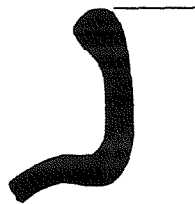

2·4·4·1

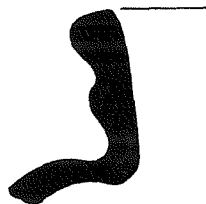

2·4·4·2



2·4·4·3



2·4·4·4

Fig. 8.7 Third millennium Mesopotamian ceramics. Classification of vessel types: 7 (Jar rim sherds) ($\frac{1}{2}$)

THIRD MILLENNIUM MESOPOTAMIAN CERAMICS
Classification of vessel types: 8 (Jar rim sherds)

Bevelled rim (2.4.5)



2.4.5.1



2.4.5.2



2.4.5.3



2.4.5.4



2.4.5.5



2.4.5.6



2.4.5.7

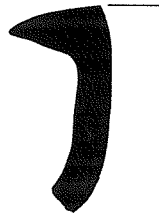

2.4.5.8



2.4.5.9

Collar/band rim (2.4.6)



2.4.6.1



2.4.6.2



2.4.6.3



2.4.6.4



2.4.6.5



2.4.6.6



2.4.6.7



2.4.6.8

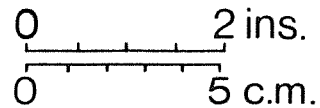

Fig. 8.8 Third millennium Mesopotamian ceramics. Classification of vessel types: 8 (Jar rim sherds) ($\frac{1}{2}$)

THIRD MILLENNIUM MESOPOTAMIAN CERAMICS
Classification of vessel types: 9 (Jar rim sherds)

Collar/band rim; dished/grooved (2.4.7)



2.4.7.1



2.4.7.2



2.4.7.3



2.4.7.4



2.4.7.5



2.4.7.6

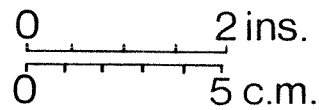

Flat rim (2.4.8)



2.4.8.1



2.4.8.2



2.4.8.3



2.4.8.4



2.4.8.5



2.4.8.6



2.4.8.7



2.4.8.8



2.4.8.9

Fig. 8.9 Third millennium Mesopotamian ceramics. Classification of vessel types: 9 (Jar rim sherds) ($\frac{1}{2}$)

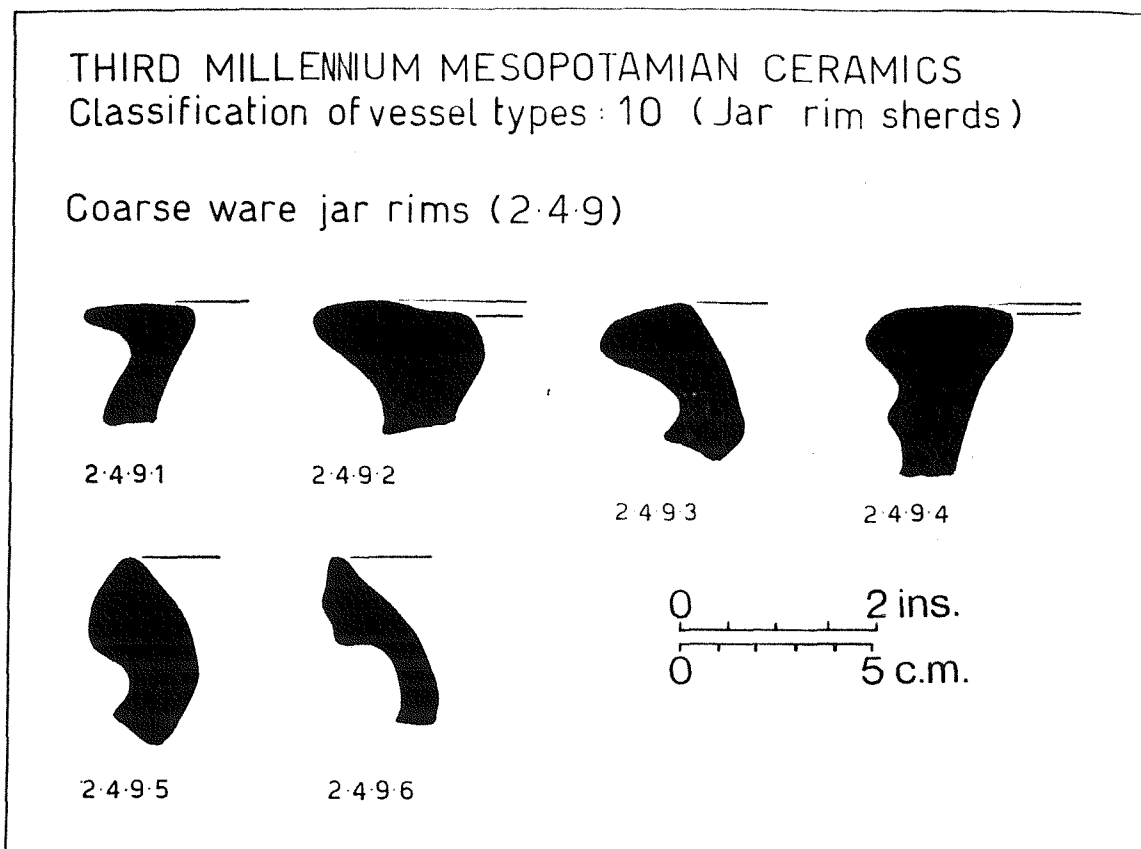
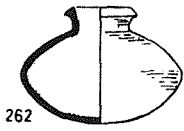

Fig. 8.10 Third millennium Mesopotamian ceramics. Classification of vessel types: 10 (Jar rim sherds) ($\frac{1}{2}$)

THIRD MILLENNIUM MESOPOTAMIAN CERAMICS Classification of vessel types: 11 (Bottles; jars)

Bottles (3:1-3:3)



Carinated bottles (3:4-3:5)

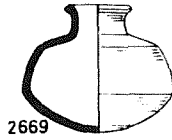

Ovoid bottles (3:6)

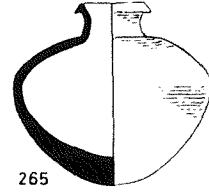

Multi-ribbed bottles (3:7)

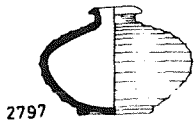

Drinking bottles (4:1)

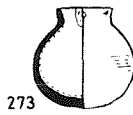

Pilgrim flasks (4:2)

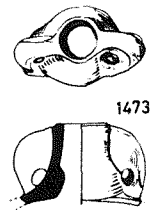

Spouted jars (5:1-5:4)

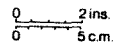
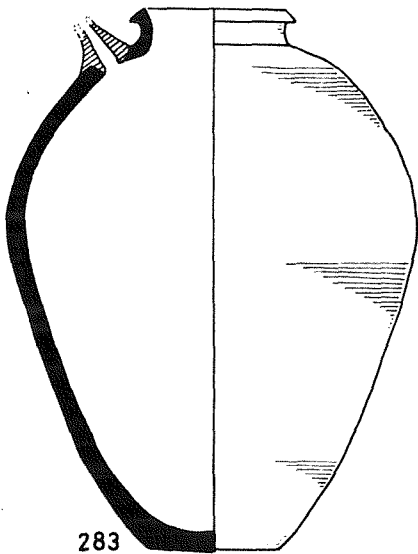

Wing-lugged jars (6)

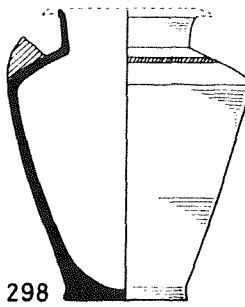

Footed cup-based jars (7)

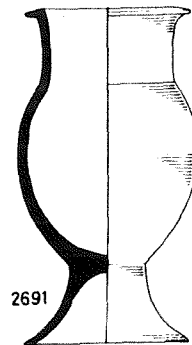
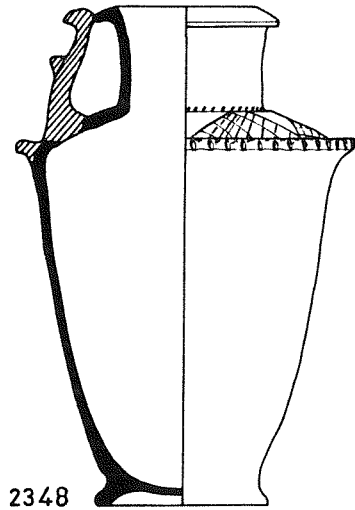

Fig. 8.11 Third millennium Mesopotamian ceramics. Classification of vessel types: 11 (Bottles; jars) (1/4)

THIRD MILLENNIUM MESOPOTAMIAN CERAMICS

Classification of vessel types: 12 (Jars; stemmed dishes; stands)

Upright-handled jars (9)



Hollow stands (11)

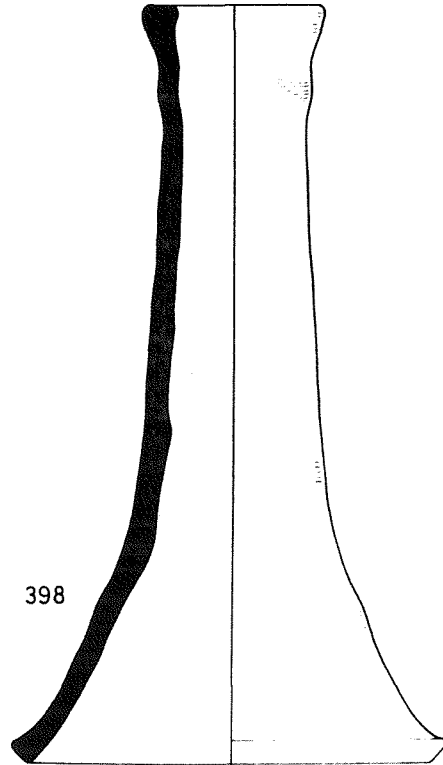

Stemmed dishes (10)

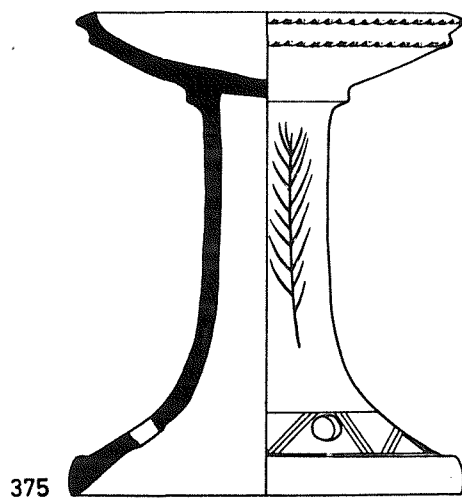

0 2 ins
0 5 c.m.

Fig. 8.12 Third millennium Mesopotamian ceramics. Classification of vessel types: 12 (Jars; stemmed dishes; stands) ($\frac{1}{2}$)

Table 8.2 Third millennium Mesopotamian ceramics: concordance of vessel types from Ur, Al 'Ubaid, Kish, Jamdat Nasr, and the Diyala region

THIRD MILLENNIUM MESOPOTAMIAN CERAMICS: CONCORDANCE OF VESSEL TYPES					
VESSEL TYPE	UR (Woolley 1934)	AL UBAID (Hall & Woolley 1919)	KISH (Mackay 1925; 1929)	JAMDAT NASR (Mackay 1931)	DIYALA (Delougaz 1952)
Conical bowls (1.1)	4a-5c, 247	I-III	O	L	B.001.200a B.002.200a,b B.003.200a,b
Transitional bowls (1.2)	3-7A	IV			B.003.210b
Goblets (1.3)	7b, 7c	V, VI, VII			B.007.700 B.076.700 B.077.700a,b
Bevel-rim bowls (BRB)			F	L	
Cups (1.4)	30a	IX, XIII	H	H	B.043.200a B.052.200a
Large bowls: flat base (1.5)	21 - 23	XIV	F	K	
Round-based bowls/ basins (1.6)		XV, XVI	F, M	K	
Ring-based bowls (1.7)		XVII, XIX	F		A.001.300
Band-/collar-rim bowls (1.8)	26, 27		(S)	K	
Sieve bowls (1.9)	248		R	J	B.001.200b B.032.500 B.042.500a
Moulded bowls (1.10)					B.041.710
Bowls with perforated rim (1.11)					B.041.503 B.043.503
Bowls: coarse ware (1.15)	1	XX	G	M	C.011
Spouted bowls (1.17)					
Small jars: flat base, plain rim (2.1.1.1)	35, 109a, 109c, 110c, 121, 122, 125-127, 179b	LIX, LXIII VIII	K, KA	L	B.175.220,224 B.185.220,224
Small jars with rim: flat base (2.1.1.2)	32a, 32b, 34, 110b, 135-137		K, M	L	A.573.200
Small jars: round base (2.1.2)	37, 41a, 83d, 90		F, L, M	E, F	A.654.520
Small jars: ring base (2.1.3)					
Medium jars: round base (2.2.1)	36, 80, 83, 93, 94, 95, 210		L		
Medium jars: flat base (2.2.2)	115, 120a, 120b	XXXI, XXXVIII XXXIX, XLVII	L	E, F, G, (K)	B.516.270 B.454.270
Medium jars: ring base (2.3.1)	158, 193		C, D		C.525.370a
Large jars: flat base (2.3.1)		XXIX, XXX, XXXII, XLI		E, F, G	D.544.240
Large jars: convex base (2.3.2)	59-61, 63 142, 157	XXXIII-XXXVI	M, (S)		
Large jars: round base (2.3.3)	98, 106a, 106b		L		B.556.520 C.555.510

VESSEL TYPE	UR (Woolley 1934)	AL UBAID (Hall & Woolley 1919)	KISH (Mackay 1925; 1929)	JAMDAT NASR (Mackay 1931)	DIYALA (Delougaz 1952)
Large jars: ring base (2.3.4)	144, 145, 148, 149 151, 155, 188	XXII, XLII	C, F(?), (S)	E, F, (K)	C.525.370b
Lids (2.6)	(247)				B.664.520b
Bottles (3.1-3.3)	41a-52b, 238	XLIII-XLVI	N		B.663.520a B.663.540b B.664.540c
Bottles: carinated (3.4-3.5)			N		B.633-B635
Bottles: ovoid body (3.6)		XLVIII, XLIX	N		
Bottles: multi-ribbed (3.7)					
Drinking bottles (4.1)	253	XCIV	J, JB		
Pilgrim flasks (4.2)					B.816.521
Spouted jars: flat base (5.1)	204, 209b	LXXVIII-LXXX LXXXII, XCI	D	A	C.526.262 C.556.242
Spouted jars: convex base (5.2)	209a	LXXXI, LXXXVI, LXXXVII, XC	D	A	D.535.542 D.545.542
Spouted jars: ring base (5.3)	208, 211, 212	LXXXIII-LXXXV	D		C.525.362a C.526.262
Spouted jars: pinched ring base (5.4)					C.514.362
Spouted jars: nipple lugs on shoulder (5.5)					
Wing-lugged jars (6)	251	XXVI XXVII			B.416.371, 373 B.526.273 C.515.373 C.516.271
Footed/cup-based jars (7)	241	XCVII	E	(K)	
Lugged jars (8.4)				B, C	C.413.253 C.414.253 D.504.353
'Well-type' (8.15)	235				
Strap handles (8.18.1)				D	
Upright-handled jars (9)	210		A		B.516, B.526 C.515-C.517, C.525-C.527 D.516 D.526
Stemmed dishes (10)	242, 243	XCVIII	B		C.363-C.367
Hollow stands (11)	245	XCVI	RA, Q		C.353-C.357
Miniatures (12)	177		J, JA(S)	E	-

CONTEXT (COLUMN 5)

The archaeological context of each sample is indicated in column 5. Unfortunately in most cases there is no recorded context for the pottery from Ur. Wherever possible a context has been quoted from the British Museum registers in the Department of Western Asiatics, although this is usually confined to a grave letter. Occasionally the grave number (e.g. PG 90) has been written on the pot and this number has been quoted both under the context and with the site number (column 2).

The archaeological context for pottery from Kish has been quoted from the Ashmolean Museum registers and with reference to Mackay's publications of the assemblages from Kish (Mackay, 1925; 1929) and Jamdat Nasr (Mackay, 1931).

Pottery from Abu Salabikh is located by reference to column 5 where the excavated square is recorded (see Postgate 1978, 79, fig. 1; 1980, 96-97; 1982, 58, fig. 45 and 60, fig. 47; 1983, fig. 354; Postgate and Moon 1982, 129, fig. 9) and to column 2 where the batch number and level is recorded.

PUBLICATION (COLUMN 6)

References generally relate to published illustrations and only the excavation report or the most recent publication is quoted. More than one reference is given when it is considered worthwhile to compare these illustrated examples in the context of different publications.

Much of the pottery from Abu Salabikh has yet to be published. With the exception of occasional references to a similar pot type illustrated elsewhere there are no published references for pottery from the Main Mound. The pottery illustrated in the catalogue of the first 99 graves excavated at Abu Salabikh (Martin et al. 1985) was published after completion of the catalogue. Reference is made, however, to McAdam's illustrated types from the West Mound (McAdam 1983, 53-86).

FABRIC CLASSIFICATION (COLUMN 7)

Excavation reports are usually published with a detailed account of the pottery from the site, but all too often scant attention has been paid to the fabrics themselves. This may be partly owing to the apparent homogeneity of much of the pottery from third millennium sites, but fabrics are frequently overlooked as potential chronological indicators. In this pottery corpus the aim has been to include descriptions of the fabric categories to which vessels can be attributed as an integral part of the assessment.

Sixteen principal fabric types have been identified initially from a visual comparison providing information concerning the possible origin, type and ware. Further, more sophisticated, comparisons based on a microscopic examination of some six hundred samples provide more detailed evidence frequently diagnostic of source (see Section 8.3).

- A Fine sandy wares
- B Green-buff wares
- C Fine wares
- D Shell-tempered wares
- E Medium sandy wares
- F Shelly wares
- Grog tempered wares (Kish only)
- G Coarse sandy wares
- H Grey wares
- I Fine (levigated) wares
- J Medium sand-tempered buff wares
- K Coarse sand-tempered buff wares
- L Fine red wares
- M Coarse red wares
- N Medium vegetable tempered wares (BRB fabric)
- P Coarse vegetable tempered wares
- Q Very coarse sand and vegetable-tempered wares.

It is not always possible to obtain samples for thin sectioning and petrological analysis. Upright-handled jars and stemmed dishes have an intrinsic value which precludes sampling unless they are incomplete; the same frequently applies to any whole pot. Thin sections are therefore mainly derived from sherds, yet almost

every fabric identified in each assemblage is represented by a thin section.

Since a chronological and typological comparison of the pottery fabrics has been attempted, the principal fabric groups remain the same for each site. Thus Fabric A from Kish is similar to Fabric A from Ur and Fabric A from Salabikh. An attempt has been made to maintain this rationalisation throughout the fabric sub-groups, although some compensation has had to be made for variation between local clays from different sites.

In order to facilitate comparisons between pottery assemblages a concordance of fabric types has been prepared (Table 8.3) to indicate the presence or absence of individual fabric categories at each site included in the corpus. Thus it is immediately apparent that grey ware (Fabric Group H) is present principally in the pottery assemblages from Abu Salabikh. In this case it is restricted to the West Mound, indicating a chronologically early fabric type.

LATE FOURTH AND THIRD MILLENNIUM MESOPOTAMIAN CERAMICS: CONCORDANCE OF FABRIC TYPES

- | | | | | |
|------------------------|-------------------------|------------------------------------|-----------------|-----------------------|
| 1. Ur | 6. Uruk/Warka | 11. Abu Salabikh: north east mound | 16. Tell Agrab | 21. Halawa |
| 2. Tell Sakheri Sughir | 7. Para | 12. Abu Salabikh: west mound | 17. Khafajah | 22. Tell Al Rubeidheh |
| 3. Tell Al'Ubaid | 8. Nippur | 13. Kish | 18. Tell Asmar | 23. Suwari |
| 4. Eridu | 9. Abu Salabikh Area E | 14. Jamdat Nasr | 19. Abu Qasim | 24. Tell Al 'Usiyeh |
| 5. Lagash | 10. Abu Salabikh Area A | 15. Tell Al Wilayah | 20. Kheit Qasim | 25. Umm An Nar |
| | | | | 26. Hili |

	1	2	3	4	5	6	7	8	9	10	11	12	13	14	15	16	17	18	19	20	21	22	23	24	25	26	
Pine sandy wares																											
Ai	-	Ai	-	Ai	-	-	-	-	-	Ai	Ai	-	Ai	Ai	Ai	-	-	-	-	-	-	-	-	-	-	-	
-	-	-	-	-	-	-	-	-	-	-	-	-	-	-	-	-	-	-	-	-	-	Ai	-	-	-	-	
Aii	Aii	Aii	Ai	Aii	-	Ai	-	Aii	-	-	Aii	Aii	-	Aii	-	Aii	-	-	-	-	-	-	Aii	-	-	-	
-	-	-	-	-	-	-	-	-	-	-	-	-	-	-	-	-	-	-	-	-	-	Aii	-	-	-	-	
Aiii	-	Aiii	Aii	-	-	Aii	-	Aiii	-	Aiii	Aiii	Aiii	Aiii	-	-	-	-	-	-	-	-	-	-	-	-	Aiii	-
Aiv	Aiv	Aiv	-	-	Aiv	Aiv	Aiv	Aiv	Aiv	Aiv	Aiv	Aiv	Aiv	Aiv	-	Aiv	Aiv	Aiv	-	Aiv	-	-	-	-	-	Aiv	Aiv
Av	Av	Av	-	-	-	-	-	-	Av	Av	-	Av	Av	-	-	-	Av	-	-	-	-	-	-	-	-	-	
Avi	-	Avi	-	-	-	-	-	-	Avi	Avi	-	Avi	Avi	-	-	-	-	-	-	-	-	-	-	-	-	-	
Avii	-	Avii	-	-	-	-	-	-	Avii	-	-	Avii	Avii	Avii	-	-	Avii	-	-	-	-	-	-	-	-	-	
-	-	-	-	-	-	-	-	-	-	-	-	-	Aviii	Aviii	-	-	-	-	-	-	-	-	-	-	-	-	
-	-	-	-	-	-	-	-	-	Aviii	Aviii	-	Aviii	-	-	-	-	-	-	-	-	-	-	-	-	-	-	
-	-	-	-	-	-	-	-	-	-	-	-	Aix	-	-	-	-	-	-	-	-	-	-	-	-	-	-	
-	-	-	-	-	-	-	-	-	-	-	-	Ax	-	-	-	-	-	-	-	-	-	-	-	-	-	-	
Green-buff wares																											
Bi	-	Bi	-	-	Bi	Bi	Bi	Bi	Bi	Bi	Bi	Bi	Bi	Bi	-	Bi	-	-	-	Bi	-	-	Bi	-	Bi	-	
-	-	-	-	-	-	-	-	-	-	-	-	-	-	-	-	-	-	-	-	-	-	Bi	-	-	-	-	

Table 8.3 Late fourth and third millennium Mesopotamian ceramics: concordance of fabric types

1	2	3	4	5	6	7	8	9	10	11	12	13	14	15	16	17	18	19	20	21	22	23	24	25	26
Bii	Bii	Bii	Bii	-	-	-	-	Bii	-	Bii	Bii	Bii	Biv	-	-	-	-	-	Bii	-	-	-	-	-	-
-	-	-	-	-	-	-	-	-	-	-	-	-	-	-	-	-	-	-	-	-	Bii	-	-	-	-
Biii	-	-	-	-	-	-	-	Biii	Biii	Biii	Biii	Biii	Bii	-	-	-	-	-	-	-	-	-	-	-	-
-	-	-	-	-	-	-	-	-	-	-	-	-	-	-	-	-	-	-	-	-	Biii	-	-	-	-
Biv	Biv	-	-	-	-	-	-	Biv	-	-	-	Biv	-	-	-	Biv	-	-	-	-	-	-	-	-	-
Bv	-	-	-	-	-	-	-	Bv	Bv	-	Bv	Bv	Biii	-	-	-	-	-	-	-	-	-	-	-	-
-	-	-	-	-	-	-	-	-	-	-	-	-	-	-	-	-	-	-	-	-	Bv	-	-	-	-
Bvi	-	-	-	-	-	-	-	Bvi	-	-	Bvi	Bvi	-	-	-	-	-	-	Bvi	-	-	-	-	Bvi	-
-	Bvii	-	-	-	-	-	-	Bvii	-	-	-	-	-	-	-	-	-	-	-	-	-	-	-	-	-
-	-	-	-	-	-	-	-	Bviii	Bviii	-	Bviii	Bviii	-	-	-	-	-	-	-	-	-	-	-	-	-
-	-	-	-	-	-	-	-	Bix	Bix	-	Bix	-	-	-	-	-	-	-	-	-	-	-	-	-	-
Fine wares																									
Ci	Ci	Ci	-	-	Ci	-	-	Ci	Ci	Ci	Ci	Ci	Ci	-	-	-	-	-	Ci	Ci	-	-	-	-	-
-	-	-	-	-	-	-	-	-	-	-	-	-	-	-	-	-	-	-	-	-	Ci	-	-	-	-
-	-	-	-	-	-	-	-	-	-	-	-	Cii	Cii	-	-	-	-	-	-	-	Cii	-	-	-	-
Cii	-	-	-	-	-	-	-	Cii	Cii	-	Cii	Ciii	-	-	-	-	-	-	-	-	-	-	-	-	-
Ciii	-	-	-	-	-	-	-	Ciii	Ciii	-	Ciii	-	-	-	-	-	-	-	-	-	-	-	-	-	-
-	-	-	-	-	-	-	-	-	-	-	-	-	-	-	-	-	-	-	-	-	Ciii	-	-	-	-
Civ	-	-	-	-	-	-	-	-	-	-	-	-	-	-	-	-	-	-	-	-	-	-	-	-	-
-	-	-	-	-	-	-	-	-	-	-	-	-	-	-	-	-	-	-	-	-	Civ	-	-	-	-

1	2	3	4	5	6	7	8	9	10	11	12	13	14	15	16	17	18	19	20	21	22	23	24	25	26
Shell tempered wares																									
Di	-	-	-	-	-	-	-	Di	-	-	Di	-	-	-	-	-	-	-	-	-	-	-	-	-	-
-	-	-	-	-	-	-	-	-	-	-	-	-	-	-	-	-	-	-	-	-	Di	-	-	-	-
Dii	-	-	-	-	-	-	-	-	-	-	Dii	-	-	-	-	-	-	-	-	-	-	-	-	-	-
-	-	-	-	-	-	-	-	Dii	Dii	-	Diii	-	-	-	-	-	-	-	-	-	-	-	-	-	-
Diii	-	-	-	-	-	-	-	-	-	-	-	Dii	-	-	-	-	-	-	-	-	-	-	-	-	-
-	-	-	-	-	-	-	-	-	-	-	-	-	-	-	-	-	-	-	-	-	Dii	-	-	-	-
-	-	-	-	-	-	-	-	-	-	-	-	-	-	-	-	-	-	-	-	-	-	-	-	-	-
-	-	-	-	-	-	-	-	Diii	Diii	-	-	Di	Di	-	-	-	-	-	-	-	-	-	-	-	-
-	-	-	-	-	-	-	-	-	-	-	-	Diii	-	-	-	-	-	-	-	-	-	-	-	-	-
-	-	-	-	-	-	-	-	-	-	-	-	-	-	-	-	-	-	-	-	-	Diii	-	-	-	-
Div	-	Div	-	-	-	-	-	-	-	-	-	-	-	-	-	-	-	-	-	-	-	-	-	-	-
-	-	-	-	-	-	-	-	-	-	-	-	-	-	-	-	-	-	-	-	-	Div	-	-	-	-
Medium sandy wares																									
Ei	Ei	Ei	Ei	Aiii	-	Aiii	Ei	Ei	Ei	Ei	Ei	Ei	Ei	-	-	-	-	Ei	-	-	Ei	-	Ei	Ei	Ei
-	-	-	-	-	-	-	-	Eii	Eii	-	Eii	Eii	Eii	-	-	-	-	Eii	-	-	Eii	-	Eii	-	-
Eii	-	-	-	-	-	-	-	-	-	-	-	Eiii	Eiii	-	-	-	-	-	-	-	-	-	-	-	-
-	-	-	-	-	-	-	-	-	-	-	-	Eiii	-	-	-	-	-	-	-	-	-	-	-	-	-
Eiii	Eiii	Eiii	-	-	-	-	-	-	-	-	-	-	-	-	-	-	-	-	-	-	-	-	-	-	-
-	-	-	-	-	-	-	-	-	-	-	-	Eiv	-	-	-	-	-	-	-	-	-	-	-	-	-

1	2	3	4	5	6	7	8	9	10	11	12	13	14	15	16	17	18	19	20	21	22	23	24	25	26
Shelly wares																									
-	-	-	-	-	-	-	-	-	-	-	Fi	-	-	-	-	-	-	-	-	-	-	-	-	Fi	-
Fi	-	-	-	-	-	-	-	-	-	-	-	-	-	-	-	-	-	-	-	-	-	-	-	-	-
Fii	-	-	-	-	-	-	-	-	-	-	-	-	-	-	-	-	-	-	-	-	-	-	-	-	-
Grog-tempered wares (Kish only)																									
-	-	-	-	-	-	-	-	-	-	-	-	Fi	-	-	-	-	-	-	-	-	-	-	-	-	-
-	-	-	-	-	-	-	-	-	-	-	-	Fii	-	-	-	-	-	-	-	-	-	-	-	-	-
Coarse sandy wares																									
Gii	-	-	-	-	-	-	-	Gi	-	-	Gi	-	-	-	-	-	-	-	Gi	Gi	-	-	-	Gi	-
Gi	-	-	-	-	-	-	-	Gii	-	-	Gii	-	-	-	-	-	-	-	-	-	-	-	-	Gii	-
-	Giii	Giii	-	-	-	-	-	-	Giii	-	-	-	-	-	-	-	-	-	-	-	-	-	-	-	-
Grey wares																									
Hi	-	-	-	-	-	-	-	Hi	-	-	Hi	-	-	-	-	-	-	-	-	-	-	-	-	-	-
-	-	-	-	-	-	-	-	-	-	-	Hii	-	-	-	-	-	-	-	-	-	-	-	-	-	-
-	-	-	-	-	-	-	-	-	-	-	Hiii	Hi	-	-	-	-	-	-	-	-	-	-	-	-	-
-	-	-	-	-	-	-	-	-	-	-	-	Hii	-	-	-	-	-	-	-	-	-	-	-	-	-
-	-	-	-	-	-	-	-	-	-	-	-	Hiii	-	-	-	-	-	-	-	-	-	-	-	-	-
-	-	-	-	-	-	-	-	-	-	-	-	Hiv	-	-	-	-	-	-	-	-	-	-	-	-	-
-	-	-	-	-	-	-	-	-	-	-	-	Hiv	-	-	-	-	-	-	-	-	-	-	-	-	-
-	-	-	-	-	-	-	-	-	-	-	-	Hv	-	-	-	-	-	-	-	-	-	-	-	-	-
-	-	-	-	-	-	-	-	-	-	-	-	Hvi	-	-	-	-	-	-	-	-	Hvi	-	-	-	-

1	2	3	4	5	6	7	8	9	10	11	12	13	14	15	16	17	18	19	20	21	22	23	24	25	26
-	-	-	-	-	-	-	-	-	-	-	Hvii	-	-	-	-	-	-	-	-	-	Hvii	-	-	-	-
-	-	-	-	-	-	-	-	-	-	-	Hviii	-	-	-	-	-	-	-	-	-	-	-	-	-	-
li	-	-	-	-	-	-	-	-	-	-	Hix	-	-	-	-	-	-	-	-	-	-	-	-	-	-
-	-	-	-	-	-	-	-	-	-	-	Hx	-	-	-	-	-	-	-	-	-	-	-	-	-	-
-	-	-	-	-	-	-	-	-	-	-	Hxi	-	-	-	-	-	-	-	-	-	-	-	-	-	-
-	-	-	-	-	-	-	-	-	-	-	Hxii	-	-	-	-	-	-	-	-	-	-	-	-	-	-
-	-	-	-	-	-	-	-	-	-	-	Hxiii	-	-	-	-	-	-	-	-	-	-	-	-	-	-
Fine (levigated) wares																									
-	-	-	-	-	-	-	-	-	-	-	Ii	Ii	-	-	-	-	-	-	-	-	-	-	-	-	-
-	-	-	-	-	-	-	-	-	-	-	Iii	Iii	-	-	-	-	-	-	-	-	-	-	-	-	-
Medium sand-tempered buff wares																									
Ji	-	-	-	-	-	-	-	-	Ji	-	-	Ji	-	-	-	-	-	-	-	-	-	-	-	-	-
Jii	Jii	-	-	-	-	-	-	-	Jii	-	-	Jii	-	-	-	-	-	-	-	-	-	-	-	-	-
-	-	-	-	-	-	-	-	-	-	-	Jiii	-	-	-	-	-	-	-	-	-	-	-	-	-	-
-	-	-	-	-	-	-	-	-	-	-	Jiv	-	-	-	-	-	-	-	-	-	-	-	-	-	-
Coarse sand-tempered buff wares																									
-	-	-	-	-	-	-	-	-	-	-	Ki	-	-	-	-	-	-	-	-	-	-	-	-	-	-
Ki	-	-	-	-	-	-	-	-	-	-	-	-	-	-	-	-	-	-	-	-	-	-	-	-	-
Kii	Kii	-	-	-	-	-	-	-	-	-	-	-	-	-	-	-	-	-	-	-	-	-	-	-	-
Fine red wares																									
-	-	-	-	-	-	-	-	-	Li	-	-	Li	-	-	-	-	-	-	-	-	-	-	-	-	-

1	2	3	4	5	6	7	8	9	10	11	12	13	14	15	16	17	18	19	20	21	22	23	24	25	26
-	-	-	-	-	-	-	-	Lii	-	-	Lii	-	-	-	-	-	-	-	-	-	-	-	-	-	-
-	-	-	-	-	-	-	-	Liii	-	-	Liii	-	-	-	-	-	-	-	-	-	-	-	-	-	-
-	-	-	-	-	-	-	-	-	-	-	Liv	-	-	-	-	-	-	-	-	-	-	-	-	-	-
Coarse red wares																									
-	-	-	-	-	-	-	-	Mi	-	-	Mi	-	-	-	-	-	-	-	-	-	-	-	-	-	-
-	-	-	-	-	-	-	-	Mii	Mii	-	Mii	-	-	-	-	-	-	-	-	-	-	-	-	-	-
-	-	-	-	-	-	-	-	Miii	-	-	Miii	-	-	-	-	-	-	-	-	-	-	-	-	-	-
-	-	-	-	-	-	-	-	Miv	-	-	Miv	-	-	-	-	-	-	-	-	-	-	-	-	-	-
-	-	-	-	-	-	-	-	Mv	-	-	Mv	-	-	-	-	-	-	-	-	-	Mv	-	-	-	-
-	-	-	-	-	-	-	-	Mvi	-	-	-	-	-	-	-	-	-	-	-	-	Mvi	-	-	-	-
-	-	-	-	-	-	-	-	-	-	-	Mvii	-	-	-	-	-	-	-	-	-	Mvii	-	-	-	-
-	-	-	-	-	-	-	-	-	-	-	Mviii	-	-	-	-	-	-	-	-	-	Mviii	-	-	-	-
Medium vegetable-tempered wares (BRB fabric)																									
-	-	-	-	-	-	-	-	Ni	-	Ni	Ni	Gi	-	-	-	-	-	-	-	-	-	-	-	-	-
-	-	-	-	-	-	-	-	Nii	-	-	Nii	Gii	-	-	-	-	-	-	-	-	-	-	-	-	-
-	-	-	-	-	-	-	-	Niii	-	-	Niii	-	-	-	-	-	-	-	-	-	-	-	-	-	-
-	-	-	-	-	-	-	-	Niv	-	-	Niv	-	-	-	-	-	-	-	-	-	-	-	-	-	-
-	-	-	-	-	-	-	-	-	-	-	Nv	-	-	-	-	-	-	-	-	-	-	-	-	-	-
-	-	-	-	-	-	-	-	-	-	-	Nvi	-	-	-	-	-	-	-	-	-	-	-	-	-	-
-	-	-	-	-	-	-	-	-	-	-	Nvii	-	-	-	-	-	-	-	-	-	-	-	-	-	-

1	2	3	4	5	6	7	8	9	10	11	12	13	14	15	16	17	18	19	20	21	22	23	24	25	26	
Coarse vegetable-tempered wares																										
Li	-	-	-	-	-	-	-	Pi	-	-	Pi	-	-	-	-	-	-	-	-	-	-	-	-	-	-	-
-	-	Lii	-	-	-	-	-	-	-	-	Pii	-	-	-	-	-	-	-	-	-	-	-	-	-	-	-
-	Kii	-	-	-	-	-	-	-	-	-	Piii	Li	-	-	-	-	-	-	-	-	-	-	-	-	-	-
Very coarse sand and vegetable-tempered wares																										
-	-	-	-	-	-	-	-	Qi	-	-	Qi	-	-	-	-	-	-	-	-	-	-	-	-	-	-	-
-	-	-	-	-	-	-	-	Qii	-	-	Qii	-	-	-	-	-	-	-	-	-	-	-	-	-	-	-
-	-	-	-	-	-	-	-	Qiii	-	-	Qiii	-	-	-	-	-	-	-	-	-	-	-	-	-	-	-
-	-	-	-	-	-	-	-	-	-	-	Qiv	-	-	-	-	-	-	-	-	-	-	-	-	-	-	-
-	-	-	-	-	-	-	-	Qv	-	-	Qv	-	-	-	-	-	-	-	-	-	-	-	-	-	-	-

ANALYSIS (COLUMNS 8 - 11)

The remaining four columns of the catalogue are a record of analyses carried out on the pottery samples (Sections 8.3 and 8.4). The thin section number is recorded in column 8 and in some cases two thin sections have been taken from the same pot. Column 9 contains the neutron activation number which will appear on subsequent cluster analyses. Columns 10 and 11 are a record of photographic archive of pottery fabrics and thin sections respectively (see also Figs. 8.93 and 8.94).

Finally, an asterisk in column 12 indicates that the pot or sherd is illustrated and may be located by its sample number on the adjoining plates.

8.2.3 Late fourth and third millennium Mesopotamian ceramics :
classification and analysis

Table 8.4 has been organised in numerical order of sample reference number. Information included in column 7, 8 and 9 is discussed in detail in Sections 8.3 and 8.4.

Table 8.4 Late Fourth and third millennium Mesopotamian ceramics: classification and analysis

LATE FOURTH AND THIRD MILLENNIUM MESOPOTAMIAN CERAMICS: CLASSIFICATION AND ANALYSIS

Key to columns

- | | | |
|------------------------------|-------------------------|-----------------------------|
| 1 Reference number | 5 Context | 9 Neutron activation number |
| 2 Museum/site number | 6 Publication | 10 Photograph number |
| 3 Date | 7 Fabric classification | 11 Photomicrograph number |
| 4 Typological classification | 8 Thin-section number | 12 Illustration |

1	2	3	4	5	6	7	8	9	10	11	12
UR											
1. <u>Bowls</u>											
1.1 Conical bowls: rim diameters > 15.0cm											
0001	BM 1935-1-13, 416 137897	ED	1.1	-	-	Aii	-	-	-	-	*
0002	BM 1935-1-13, 415 137896	ED	1.1	-	-	Aii	-	-	-	-	*
0003	BM 1919-10-11, 350	ED	1.1	-	-	Eiii	-	-	-	-	*
0004	BM 1928-10-10, 648 121951	ED	1.1	-	-	Biii	-	-	-	-	*
0005	Birmingham 111'52	ED	1.1	-	-	Di	-	-	-	-	*
0006	BM 1935-1-13, 393 137874 U14937	ED	1.1	-	-	Aiii	-	-	-	-	*
0007	BM 1935-1-13, 414 137895	ED	1.1	-	-	Di	-	-	-	-	*
0008	BM 1935-1-13, 419 137900	ED	1.1	-	-	Bv	-	-	-	-	*
0009	BM 1927-5-27, 296	ED	1.1	-	-	Bv	-	-	-	-	*
0010	BM 1935-1-13, 413 137894	ED	1.1	-	-	Di	-	-	-	-	*
0011	BM 1919-10-11, 4800	ED	1.1	-	-	Bii	143	-	-	-	*
0012	BM 1919-10-11, 551	ED	1.1	-	-	Diii	174	-	-	52/26	*
0013	BM 1919-10-11, 501 1178246	ED	1.1	-	-	Aii	-	-	-	-	*

1	2	3	4	5	6	7	8	9	10	11	12
0014	BM 1935-1-13, 610 138091	ED	1.1	-	-	Aii	-	-	-	-	*
0015	BM 1919-10-11, 4897	ED	1.1	-	-	Ci	-	-	-	-	*
0016	BM 1928-10-10, 644 121947	ED	1.1	-	-	Biii	-	-	-	-	*
0017	Birmingham 111'45	ED	1.1	-	-	Aiv	261	-	-	-	*
0018	BM 1919-10-11, 4895	ED	1.1	-	-	Fi	-	-	-	-	*
0019	BM 1935-1-13, 710 138291	ED	1.1	-	-	Aiv	-	-	-	-	*
0020	Birmingham C69	ED	1.1	-	-	Bi	-	-	-	-	*
0021	BM 1928-10-10, 645 121948	ED	1.1	Tomb A	-	Bii	-	-	-	-	*
0022	BM 1919-10-11, 355	ED	1.1	-	-	Ei	-	-	-	-	*
0023	Birmingham C80	ED	1.1	-	-	Aiv	-	-	-	-	*
0024	BM 1919-11-11, 1748	ED	1.1	-	-	Bii	144	-	-	52/10	*
0025	BM 1919-10-11, 514 117859	ED	1.1	-	-	Bi	-	-	-	-	*
1.1	Conical bowls: rim diameter < 15.0cm										
0026	Birmingham 455'33	ED	1.1	-	-	Eiii	-	-	-	-	*
0027	BM 1919-10-11, 436	ED	1.1	Tomb H	-	Cii	149	-	-	-	*
0028	BM 1928-10-10, 643 121946	ED	1.1	-	-	Biv	-	-	-	-	*
0029	Birmingham C65	ED	1.1	-	-	Ei	-	-	-	-	*
0030	BM 1928-10-10, 646 121949	ED	1.1	-	-	Aii	-	-	-	-	*
0031	Birmingham 107'52	ED	1.1	-	-	Av	-	-	-	-	*
0032	BM 1919-10-11, 548	ED	1.1	-	-	Aiii	-	-	-	-	*
0033	Birmingham C62	ED	1.1	-	-	Aiii	-	-	-	-	*

1	2	3	4	5	6	7	8	9	10	11	12
0034	BM 1919-10-11, 4894	ED	1.1	-	-	Aii	-	-	-	-	*
0035	Birmingham C64	ED	1.1	-	-	Di	-	-	-	-	*
0036	Birmingham C63	ED	1.1	-	-	Aiii	-	-	-	-	*
0037	BM 1919-10-11, 4896	ED	1.1	-	-	Other :2	177	-	10/28	52/25	*
0038	Birmingham 104'52	ED	1.1	-	-	Aii	-	-	-	-	*
0039	Birmingham 106'52	ED	1.1	-	-	Bi	279	-	13/2	-	*
0040	Birmingham C70	ED	1.1	-	-	Ciii	-	-	-	-	*
0041	Birmingham C68	ED	1.1	-	-	Di	-	-	-	-	*
0042	Birmingham C61	ED	1.1	-	-	Biii	-	-	-	-	*
0043	BM 1928-10-10, 647 121950	ED	1.1	-	-	Bii	-	-	-	-	*
0044	BM 1919-10-11, 552	ED	1.1	-	-	Fi	175	-	-	-	*
0045	Birmingham 105'52	ED	1.1	-	-	Aii	-	-	-	-	*
0046	Birmingham C67	ED	1.1	-	-	Ci	-	-	-	-	*
0047	BM 1919-10-11, 4912	ED	1.1	-	-	Aiv	-	-	-	-	*
0048	BM 1919-10-11, 4915 117685	ED	1.1	-	-	Cii	-	-	-	-	*
0049	BM 1856-9-8, 74	ED	1.1	-	-	Bv	-	-	-	-	*
0050	BM 1919-10-11, 4899	ED	1.1	-	-	Aii	127	-	-	-	*
0051	BM 1919-10-11, 4927	ED	1.1	-	-	Ai	111	-	-	-	*
0052	BM 1924-9-20, 349 117086 U1687	ED	1.1	-	-	Bii	-	-	-	-	*
0053	BM 1935-1-13, 417 137898	ED	1.1	-	-	Cii	-	-	-	-	*

1	2	3	4	5	6	7	8	9	10	11	12
0054	BM 1919-10-11, 351 117847	ED	1.1	-	-	Aii	-	-	-	-	*
0055	Birmingham C78	ED	1.1	-	-	Aiii	-	-	-	-	*
0056	BM 1919-10-11, 4911	ED	1.1	-	-	Ai	-	-	-	-	*
0057	BM 1919-10-11, 4928	ED	1.1	-	-	Biii	-	-	-	-	*
0058	BM 1919-10-11, 4814 115400	ED	1.1	-	-	Cii	-	-	-	-	*
0000	BM 1856-9-8, 30	ED	1.1	-	-	Bv	-	-	-	-	*
0060	BM 1919-10-11, 517	ED	1.1	-	-	Ci	-	-	-	-	*
0061	Birmingham C66	ED	1.1 waster	-	-	Bv	-	-	-	-	*
0062	BM 1919-10-11, 515	ED	1.1	-	-	Di	-	-	-	-	*
0063	BM 1935-1-13, 736 138317	ED	1.1	-	-	Aii	128	-	-	-	*
0064	BM 1919-10-11, 516	ED	1.1	-	-	Ciii	-	-	-	-	*
0065	BM 1919-10-11, 553	ED	1.1	-	-	Cii	150	-	-	52/14	*
0066	BM A1919-10-11	ED	1.1	-	-	Ai	-	-	-	-	*
0067	Birmingham C79	ED	1.1	-	-	Aiii	-	-	-	-	*
0068	Birmingham 103'52	ED	1.1	-	-	Aiv	-	-	-	-	*
0069	BM 1919-10-11, 554	ED	1.1	-	-	Bi	-	-	-	-	*
0070	BM 1928-10-10, 641	ED	1.1	-	-	Civ	-	-	-	-	*
0071	Birmingham 7'33 3 U6689	ED	1.1	-	-	Ci	-	-	-	-	*
0072	Birmingham 176'52	ED	1.1	-	-	Di	-	-	-	-	*
0073	BM 1928-10-10, 639	ED	1.1	-	-	Ci	-	-	-	-	*

1	2	3	4	5	6	7	8	9	10	11	12
0074	BM 1935-1-13, 429 137910	ED	1.1	-	-	Bii	-	-	-	-	*
0075	BM 1935-1-13 410 137891 U17857	ED	1.1	-	-	Aiii	-	-	-	-	*
0076	Birmingham no acc.	ED	1.1	-	-	Other :3	319	B120	12/8	-	-
0077	BM 1919-10-11, 4976	-	1.1	Tell-Sakhari	-	Bi	-	-	-	-	*
0078	BM 1919-10-11, 523	-	1.1 waster	-	-	Bv	-	-	-	-	*
0079	Birmingham no acc.	-	1.1	-	-	Aiii	313	B119	12/5	-	*
1.3 Goblets											
1.3.1 Footed Goblets											
0080	BM 1935-1-13, 700 138281	-	1.3.1	-	-	Aiv	-	-	-	-	*
0081	BM 1928-10-10, 767 U12778	-	1.3.1 14.1.1	-	-	Bi Bi	159 163	-	-	-	*
0082	Birmingham 119'52	-	1.3.1	-	-	Di	-	-	-	-	-
0083	BM 1929-10-17, 713 12774	-	1.3.1	-	-	Aiv	-	-	-	-	*
0084	BM 1928-10-10, 650 121953	-	1.3.1	-	-	Aiv	-	-	-	-	*
0085	BM 1928-10-10, 652 121955	-	1.3.1	-	-	Aiv	-	-	-	-	*
0086	Birmingham 7'33-7 C-60	-	1.3.1	-	-	Aii	-	-	-	-	*
0087	BM 1919-10-11, 2799	-	1.3.1	-	-	Bii	141	-	10/38	-	*
0088	BM 1928-10-10, 654 121957	-	1.3.1	-	-	Aiv	-	-	-	-	*
0089	BM 1928-10-10, 653 121956	-	1.3.1	-	-	Bii	-	-	-	-	*
0090	BM 1928-10-10, 651 121954	-	1.3.1	-	-	Aiii	-	-	-	-	*
0091	BM 1929-10-17, 709	-	1.3.1	-	-	Aiv	-	-	-	-	*

1	2	3	4	5	6	7	8	9	10	11	12
0092	Birmingham C-59	-	1.3.1	-	-	Ci	-	-	-	-	-
0093	BM 1935-1-13, 569 138050	-	1.3.1	-	-	Aii	-	-	-	-	*
0094	BM 1919-10-11, 4976	-	1.3.1	-	-	Bii	-	-	-	-	*
0095	Birmingham 1919-10-11, 2798	ED I/II	1.3.1	-	-	Aii	276	B118	-	-	*
1.3.2 Solid-footed goblets											
0096	BM 1935-1-13, 704 138285	ED I	1.3.2	-	-	Avi	-	-	-	-	*
0097	BM 1935-1-13, 692 138273	ED I	1.3.2	-	-	Aii	117 118	-	-	-	*
0098	Birmingham 1919-10-11, 2393	ED I	1.3.2 (waster)	-	-	-	322	B117	-	-	*
0099	BM 1935-1-13, 690 138272	ED I	1.3.2	-	-	Aiv	-	-	-	-	*
0100	BM 1919-11-11, 1753	ED I	1.3.2	-	-	Biii	-	-	11/3	52/11	*
Bevel-rim bowl (ERB)											
0101	BM 1919-10-11, 513	Uruk	-	-	-	Kii	-	-	-	-	*
1.6 Round-based bowls/basins											
1.6.2 Round-based bowls: large											
0102	BM 1919-10-11, 4936 120407	-	1.6.2	-	-	Aiv	-	-	-	-	*
0103	BM 1919-10-11, 4934 120405	-	1.6.2	-	-	Li	-	-	-	-	*
0104	BM 1919-10-11, 4934 120406	-	1.6.2	-	-	Li	-	-	-	-	*
0105	BM 1935-1-13, 806 139459	-	1.6.2	-	-	Di	171	-	9/10	52/24	*
1.8 Band/collar rim bowls											
0106	BM 1919-10-11, 561	Akkad.?	1.8	-	-	Ciii	-	-	-	-	*
0107	BM 1919-10-11, 562	Akkad.?	1.8	-	-	Bi	162	-	-	-	*

1	2	3	4	5	6	7	8	9	10	11	12
0108	BM 1919-10-11, 4948	Akkad.?	1.8	-	-	Ciii	-	-	-	-	*
0109	BM 1919-10-11, 2790	Akkad.?	1.8	-	-	Avi	-	-	-	-	*
1.9 Sieve bowls											
1.9.1 Sieve bowls: flat base (string-cut)											
0110	BM 1924-9-20, 144 116883 U1472	Akkad.?	1.9.1 14.1.1	-	-	Aiii	-	-	-	-	*
1.9.2 Sieve bowls: round base											
0111	BM 1923-11-10, 85 116496	ED ?	1.9.2	-	-	Aiii	-	-	-	-	*
0112	BM 1919-10-11, ?	ED ?	1.9.2	-	-	Bv	-	-	-	-	*
0113	Birmingham 44'52	ED ?	1.9.2	-	-	Avi	-	-	-	-	*
0114	BM 1928-10-10, 673 121976	ED ?	1.9.2	-	-	Aiii	-	-	-	-	*
0115	BM 1929-10-17, 737	ED ?	1.9.2	-	-	Bv	-	-	-	-	*
Bowls: other											
0116	BM 1935-1-13, 138312	ED ?	1.14.3.1 14.1.1	-	-	Aiii	172	-	9/29	-	*
0117	BM 1919-10-11, 353	-	1.14.8.10 8.17.1	-	-	Hi	-	-	-	-	*
2 Jars											
2.1 Small jars											
2.1.1 Small jars: flat base (string-cut)											
0118	BM 1928-10-10, 506 121776	ED III?	2.1.1.1	-	-	Aiii	-	-	-	-	*
0119	BM 1935-1-13, 577 138058	ED III?	2.1.1.1	-	-	Bii	-	-	-	-	*
0120	Birmingham 159'52	ED III?	2.1.1.1	-	-	Ciii	-	-	-	-	*

1	2	3	4	5	6	7	8	9	10	11	12
0121	BM 1928-10-10, 509 121779	ED III?	2.1.1.1	-	-	Bvi	-	-	-	-	*
0122	BM 1935-1-13, 572 138053	ED	2.1.1.1	-	-	Bi	-	-	-	-	*
0123	Birmingham C-33	ED	2.1.1.1	-	-	Ciii	-	-	-	-	*
0124	Birmingham C-32	ED III?	2.1.1.1	-	-	Bi	-	-	-	-	-
0125	Birmingham C-29	ED III?	2.1.1.1	-	-	Aiv	-	-	-	-	*
0126	Birmingham C-34	ED III?	2.1.1.1	-	-	Ciii	-	-	-	-	*
0127	Birmingham C-26	ED III?	2.1.1.1	-	-	Ciii	-	-	-	-	-
0128	Birmingham 161'52 1206	ED III?	2.1.1.1	-	-	Aiv	-	-	-	-	*
0129	BM 1919-10-10, 5205	ED III?	2.1.1.1	-	-	Aii	-	-	-	-	*
0130	BM 1928-10-10, 511 121781	ED III?	2.1.1.1	-	-	Diii	-	-	-	-	*
0131	Birmingham C-20	ED III?	2.1.1.1	-	-	Di	-	-	-	-	*
0132	BM 1919-10-11, 511	ED III?	2.1.1.1	-	-	Biii	-	-	-	-	*
0133	Birmingham C-35	ED III?	2.1.1.1	-	-	Ciii	-	-	-	-	-
0134	BM 1928-10-10, 510 121780	ED III?	2.1.1.1	-	-	Biii	-	-	-	-	*
0135	BM 1928-10-10, 507 121777	ED III?	2.1.1.1	-	-	Aii	-	-	-	-	*
0136	Birmingham C-31	ED III?	2.1.1.1	-	-	Ciii	-	-	-	-	-
0137	Birmingham C-17	ED III?	2.1.1.1	-	-	Ciii	-	-	-	-	-
0138	BM 1928-10-10, 508 121778	ED III?	2.1.1.1	-	-	Diii	-	-	-	-	*
0139	Birmingham C-15	ED III?	2.1.1.1	-	-	Aiv	-	-	-	-	*
0140	Birmingham 160'52	ED III?	2.1.1.1	-	-	Ciii	-	-	-	-	*
0141	Birmingham 170'52	ED III?	2.1.1.1	-	-	Ciii	-	-	-	-	*
0142	Birmingham C-23	ED III?	2.1.1.1	-	-	Li	-	-	-	-	*

1	2	3	4	5	6	7	8	9	10	11	12
0143	BM 1935-1-13, 571 138052	ED III?	2.1.1.1	-	-	Avi	-	-	-	-	*
0144	Birmingham C-19	ED III?	2.1.1.1	-	-	Di	266	-	-	-	*
0145	BM 1935-1-13, 568 138049	ED III?	2.1.1.1	-	-	Bii	-	-	-	-	*
0146	Birmingham C-18	ED III?	2.1.1.1	-	-	Ciii	-	-	-	-	*
0147	BM 1856-9-8, 22 118399	ED III?	2.1.1.1	-	-	Civ	-	-	-	-	*
0148	BM 1935-1-13, 420 137901	ED III?	2.1.1.1	PG 175	-	Ciii	-	-	-	-	*
0149	Birmingham C-14	ED III?	2.1.1.1	-	-	Aii	-	-	-	-	*
0150	BM 1935-1-13, 570 138051	ED III?	2.1.1.1	-	-	Aiii	-	-	-	-	*
0151	BM 1935-1-13, 586 138067	ED III?	2.1.1.1.1	-	-	Aii	-	-	-	-	*
0152	BM 1928-10-10, 518 121788	ED III?	2.1.1.1.2	-	-	Avi	-	-	-	-	*
0153	BM 1935-1-13, 591 138072	ED III?	2.1.1.1.3	-	-	Aiii	-	-	-	-	*
0154	BM 1928-10-10, 530 121800	ED III?	2.1.1.1.3	-	-	Aiii	-	-	-	-	*
0155	BM 1928-10-10, 526 121796	ED III?	2.1.1.1.3	-	-	Aiv	-	-	-	-	*
0156	BM 1935-1-13, 676 138257	ED III?	2.1.1.1.3	-	-	Aiv	-	-	-	-	*
0157	Birmingham C-40	ED III?	2.1.1.1.3	-	-	Di	-	-	-	-	*
0158	BM 1935-1-13, 576 138057	ED III?	2.1.1.1.4	-	-	Aiii	136	-	10/3	52/4	*
0159	BM 1935-1-13, 584 138065	ED	2.1.1.1.5	-	-	Aiii	139	-	10/6	52/9	*
0160	BM 1935-1-13, 421 137902	ED	2.1.1.1.5	PG 76	Woolley 1934, 415	Diii	-	-	-	-	*
0161	BM 1928-10-10, 608 121911	ED	2.1.1.1.6	-	-	Aiv?	-	-	-	-	*
0162	BM 1935-1-13, 575 138056	Akkad.	2.1.1.1.7	-	-	Ci	265	-	-	-	-
0163	BM 1919-10-11, 399	ED	2.1.1.2.1	-	-	Ciii	-	-	-	-	*

1	2	3	4	5	6	7	8	9	10	11	12
0164	BM 1928-10-10, 529 121799	ED?	2.1.1.2.1	-	-	Di	169	-	-	-	*
0165	BM 1928-10-10, 528 121798	ED?	2.1.1.2.1	-	-	Ci	-	-	-	-	*
0166	Birmingham 433'62	ED	2.1.1.2.1	-	-	Di	-	-	-	-	*
0167	BM 1928-10-10, 517 121787	ED	2.1.1.2.1	-	-	Aiv	-	-	-	-	*
0168	BM 1919-10-11, 386	ED	2.1.1.2.1	Tomb I	-	Aiii	-	-	-	-	*
0169	BM 1919-10-11, ?	ED	2.1.1.2.1	-	-	Div	164	-	9/8	-	*
0170	BM 1928-10-10, 515 121785	ED	2.1.1.2.1	-	-	Aiii	-	-	-	-	*
0171	BM 1919-10-11, 531	ED	2.1.1.2.1	-	-	Div	-	-	-	-	*
0172	Birmingham 141'52	ED	2.1.1.2.1	-	-	Di	317	-	-	-	*
0173	BM 1928-10-10, 514 121784	ED	2.1.1.2.1	-	-	Bv	-	-	-	-	*
0174	BM 1919-10-11, 390	ED	2.1.1.2.1	Tomb J	-	Eii	-	-	-	-	*
0175	BM 1928-10-10, 520 121790	ED	2.1.1.2.1	-	-	Bii	-	-	-	-	*
0176	Birmingham 7'33-214	ED	2.1.1.2.1	-	-	Bii	-	-	-	-	*
0177	BM 1919-10-11, 559	ED	2.1.1(?) .2.1	-	-	Ciii	158	-	9/25	-	*
0178	BM 1928-10-10, 606 121909	ED	2.1.1.2.1.1	-	-	Aii	-	-	-	-	*
0179	BM 1928-10-10, 593 121896	ED	2.1.1.2.1.1	-	-	Biii?	-	-	-	-	*
0180	BM 1927-10-3, 116 119121 U2737	ED	2.1.1.2.1.1	-	-	Biii	176	-	9/32	52/27	*
0181	BM 1928-10-10, 519 121789	ED	2.1.1.2.2	-	-	Ciii	-	-	-	-	*
0182	Birmingham 168'52	ED	2.1.1.2.2	-	-	Biii	-	-	-	-	*
0183	BM 1928-10-10, 524 121794	ED	2.1.1.2.2	-	-	Eii	-	-	-	-	*
0184	BM 1928-10-10, 525 121795	ED	2.1.1.2.2	-	-	Aiii	-	-	-	-	*

1	2	3	4	5	6	7	8	9	10	11	12
0185	BM 1935-1-13, 590 138071	ED	2.1.1.2.2.1	-	-	Aiii	-	-	-	-	*
0186	BM 1919-10-11, ?	ED?	2.1.1.2.3	-	-	Di	-	-	18/24	-	*
0187	BM 1928-10-10, 512 121782	Akkad.?	2.1.1.2.4	-	-	Avi	-	-	-	-	*
0188	BM 1928-10-10, 513 121783	Akkad.?	2.1.1.2.5	-	-	Avi	-	-	-	-	*
0189	BM 1928-10-10, 512 121791	ED?	2.1.1.2.6	-	-	Aiv	-	-	-	-	*
2.1.2 Small jars: round base											
0190	BM 1928-10-10, 590 121893 U10816	ED	2.1.2.1	PG 789	-	Aiv	-	-	-	-	*
0191	BM 1928-10-10, 586 121889	ED	2.1.2.1	-	-	Aii	-	-	-	-	*
0192	BM 1928-10-10, 596 121899	ED	2.1.2.1	-	-	Ciii	-	-	-	-	*
0193	BM 1928-10-10, 595 121898	ED?	2.1.2.2	-	-	Eii	-	-	-	-	*
0194	BM 1928-10-10, 585 121888	ED?	2.1.2.2	-	-	Aiv	-	-	-	-	*
0195	BM 1919-10-11, 558	ED?	2.1.2(?) .2	-	-	Ci	-	-	-	-	*
0196	BM 1928-10-10, 581 121884	ED	2.1.2.2	-	-	Avi	-	-	-	-	*
0197	BM 1928-10-10, 587 121890	Akkad.	2.1.2.2	-	-	Avi	-	-	-	-	*
0198	BM 1928-10-10, 582 121885	ED	2.1.2.2	-	-	Biii	-	-	-	-	*
0199	BM 1928-10-10, 580 121883	Akkad.	2.1.2.2	-	-	Aiv	-	-	-	-	*
0200	BM 1928-10-10, 579 121849	ED?	2.1.2.3	ED Tombs	-	Aiii	-	-	-	-	*
0201	BM 1928-10-10, 583 121886	Akkad.	2.1.2.3	-	-	Bv	-	-	-	-	*
0202	BM 1928-10-10, 577 121847	Akkad.	2.1.2.3	-	-	Aii	-	-	-	-	*
0203	Birmingham 184'52	ED?	2.1.2.4	-	-	Bi	-	-	-	-	*
0204	BM 1928-10-10, 584 121887	ED?	2.1.2.5	-	-	Gi	-	-	-	-	*

1	2	3	4	5	6	7	8	9	10	11	12
2.2 Medium jars											
2.2.1 Medium jars: round base											
0205	BM 1928-10-10, 574 121844	ED?	2.2.1.1	-	-	Avi	-	-	-	-	*
0206	BM 1928-10-10, 578	ED?	2.2.1.2 2.4.1.2	-	-	Aiii	-	-	-	-	*
0207	BM 1919-10-10, ? 121188	ED?	2.2.1.3	-	-	Ji	-	-	-	-	*
0208	BM 1919-10-10, ? 121186	ED?	2.2.1.3	-	-	Aii	-	-	-	-	*
0209	BM 1935-1-13, 600 138081	ED?	2.2.1.3	-	-	Bii	-	-	-	-	*
0210	BM 1935-1-13, 732 138313	ED?	2.2.1.3	-	-	Bii	-	-	-	-	*
0211	BM 1928-10-10, 572 121842	Akkad.	2.2.1.3	-	-	Avi	-	-	-	-	*
0212	BM 1919-10-11, 567	-	2.2.1.3	-	-	Ci	-	-	-	-	*
0213	BM 1935-1-13, 717 138298	ED III?	2.2.1.4	-	-	Aiii	-	-	-	-	*
0214	BM 1935-1-13, 707 138288	Akkad.?	2.2.1.6 8.17.3	-	-	Ci	-	-	-	-	-
0215	BM 1935-1-13, 588 138069	Akkad.	2.2.1.6	-	-	Ci	-	-	-	-	-
0216	BM 1919-10-11, 360	Akkad.	2.2.1.5	Tomb J	-	Cii	-	-	-	-	*
0217	BM 1935-1-13, 678 138259	Akkad.	2.2.1.5	-	-	Cii	-	-	-	-	*
0218	BM 1935-1-13, 733 138314	Akkad.?	2.2.1.5	-	-	Ci	-	-	-	-	-
2.2.2 Medium Jars: flat base											
0219	BM 1933-10-13, 251	ED II?	2.2.2.2	-	-	Avi	-	-	-	-	*
0220	BM 1928-10-10, 523 121793	ED	2.2.2.3	-	-	Bii	-	-	-	-	*
0221	BM 1928-10-10, 522 121792	ED	2.2.2.3	-	-	Aiii	-	-	-	-	*
0222	BM 1935-1-13, 592 138073	ED II/III?	2.2.2.5	-	-	Biii	-	-	-	-	*

1	2	3	4	5	6	7	8	9	10	11	12
0223	BM 1935-1-13, 589 138070	ED II/III?	2.2.2.5	-	-	Aii	-	-	-	-	*
0224	BM 1928-10-10, 599 121902	Akkad.	2.2.2.6	-	-	Other 5	-	-	-	-	-
0225	BM 1928-10-10, 531 121801	Akkad.	2.2.2.6	-	-	Other 6	-	-	-	-	-
2.2.3 Medium jars: ring base											
0226	BM 1935-1-13, 683 138264	ED II/III?	2.2.3.1	-	-	Avi	-	-	-	-	*
0227	Birmingham 96'52	ED II/III?	2.2.3.2 14.3.1	-	-	Avi	-	-	-	-	*
0228	BM 1935-1-13, 595 138076	Akkad.?	2.2.3.5	-	-	Ci	-	-	-	-	-
0229	BM 1919-10-11, 2771	Uruk	2.1 8.18.1	-	-	Jii	178	-	11/17 11/36	52/28 52/29	* -
2.3 Large jars											
2.3.2 Large jars: convex base											
0230	BM 1928-10-10, 560 121830	ED?	2.3.2.1	-	-	Bi	-	-	-	-	*
0231	BM 1935-1-13, 620 138101	ED?	2.3.2.1	-	-	Ci	-	-	-	-	*
0232	BM 1928-10-10, 569 121839	ED?	2.3.2.1	-	-	Cii	-	-	-	-	*
0233	BM 1928-10-10, 571 121841	ED?	2.3.2.2	-	-	Cii	-	-	-	-	*
0234	BM 1928-10-10, 567 121837	ED?	2.3.2.2	-	-	Cii?	-	-	-	-	*
0235	BM 1928-10-10, 563 121833	ED?	2.3.2.2	-	-	Cii	-	-	-	-	*
0236	BM 1928-10-10, 559 121829	ED?	2.3.2.2	-	-	Cii	-	-	-	-	*
0237	BM 1928-10-10, 558 121828	ED?	2.3.2.2	-	-	Cii	-	-	-	-	*
0238	BM 1928-10-10, 565 121835	ED?	2.3.2.2	-	-	Div	-	-	-	-	*
0239	Birmingham 7'33-2	ED?	2.3.2.3	-	Woolley 1934 pl.262, no.173	Avi	-	-	-	-	*

1	2	3	4	5	6	7	8	9	10	11	12
0240	BM 1928-10-10, 562 121832	ED?	2.3.2.5	-	-	Cii	-	-	-	-	*
2.3.3 Large jars: round base											
0241	BM 1924-9-20, 363 117114 U1665	Akkad.?	2.3.3.1	-	-	Li	-	-	-	-	*
0242	BM 1935-1-13, 621 138102	ED?	2.3.3.1	-	c.f. Woolley 1934, 391, pl.257, no.98	Dii	-	-	-	-	*
2.3.4 Large jars: ring base											
0243	BM 1928-10-10, 561 121831	ED	2.3.4.3	ED Graves	-	Di	-	-	-	-	*
0244	BM 1927-10-3, 277	ED	2.3.4.3	-	-	Ci	-	-	-	-	*
0245	BM 1928-10-10, 540 121810	ED	2.3.4.3	ED Graves	-	Di	-	-	-	-	*
0246	BM 1926-10-10, 543 121813	ED	2.3.4.3	ED Graves	-	Di	-	-	-	-	*
0247	BM 1928-10-10, 542 121812	ED	2.3.4.3	-	Woolley 1934, 389	Avi	-	-	-	-	*
0248	BM 1928-10-10, 539 121809	ED III?	2.3.4.3	ED Graves	-	Eii	-	-	-	-	*
0249	BM 1928-10-10, 541 121811	ED III?	2.3.4.3	-	-	Di	-	-	-	-	*
0250	BM 1935-1-13, 616 138097	ED III?	2.3.4.4	-	-	Avi	-	-	-	-	*
0251	BM 1928-10-10, 632 121935	L. ED III?	2.3.4.5	ED Tombs	-	Avi	-	-	-	-	*
0252	BM 1935-1-13, 680 138261	Akkad.?	2.3.4.5	-	-	Ei	-	-	-	-	*
0253	BM 1935-1-13, 685 138261	Akkad.?	2.3.4.6	-	-	Ci	148	-	10/12	-	*
0254	BM 1928-10-10, 627 121930	E. Akkad.?	2.3.4.7	-	-	Bi	-	-	-	-	*
2.4 Jar rim sherds											
2.4.3 Jar rim sherds: long neck											
0255	BM 1933-1-12, 81	ED	2.4.3.3 5?	-	-	Aiii	137	-	10/35	-	*

1	2	3	4	5	6	7	8	9	10	11	12	
2.4.5 Jar sherds: bevelled rim												
0256	Birmingham	no acc.	ED	2.4.5.1	-	-	Ei	302	-	12/29	-	*
0257	Birmingham	no acc.	ED	2.4.5.6	-	-	Ei	301	-	B31	-	*
0258	BM 1933-10-13,	252	ED I	2.4.5.8	-	-	Aiii	138	-	9/1	-	*
3 Bottles												
3.1 Bottles: bevelled rim												
0259	BM 1919-10-11,	?	ED?	3.1	-	-	Avi	-	-	-	-	*
0260	BM 1919-10-11,	389	ED?	3.1	Tomb J	-	Avi	-	-	-	-	*
0261	BM 1919-10-11,	381	ED?	3.1	Tomb J	-	Aiv	-	-	-	-	*
0262	BM 1928-10-10,	495 121765	ED?	3.1	-	-	Ci	-	-	-	-	*
3.2 Bottles: everted rim												
0263	BM 1927-10-3,	114 119119 U2984B	ED?	3.2	-	-	Avi?	-	-	-	-	*
0264	BM 1928-10-10,	497 121767	ED?	3.2	-	-	Avi	-	-	-	-	*
0265	BM 1928-10-10,	496 121766	ED?	3.2	-	-	Avi?	-	-	-	-	*
3.3 Bottles: long neck												
0266	BM 1928-10-10,	501 121771	ED?	3.3	-	-	Avi	-	-	-	-	*
0267	BM 1928-10-10,	498 121768 U75	ED?	3.3	-	-	Gii	-	-	-	-	*
3.4 Bottles: carinated shoulder and square body												
0268	BM 1929-10-17,	706	ED?	3.4	-	-	Other :7	-	-	-	-	*
0269	BM 1928-10-10,	499 121769	ED?	3.4	-	-	Ci	-	-	-	-	*
0270	BM 1928-10-9,	461 120903	ED?	3.4	-	-	Aiv	-	-	-	-	*

1	2	3	4	5	6	7	8	9	10	11	12
3.5 Bottles: carinated shoulder											
0271	BM 1928-10-10, 500 121770	ED?	3.5	-	-	Avi	-	-	-	-	*
0272	BM 1928-10-10, 589 121892	ED?	3.5	-	-	Avi	-	-	-	-	*
4.1 <u>'Drinking' bottles: double-mouthed</u>											
0273	BM 1924-9-20, 131 116870 U1542	ED?	4.1	-	-	Avi	-	-	-	-	*
5 <u>Spouted jars</u>											
5.1 Spouted jars: flat base											
5.1.1 Small spouted jars: flat base											
0274	BM 1935-1-13, 578 138059	ED II/III?	5.1.1.1	-	-	Ciii	-	-	-	-	*
0275	BM 1933-10-13, 249	ED II/III?	5.1.1.2 5.7.2	-	-	Av	264	-	-	51/9	*
5.1.2 Spouted jars: flat base, round body											
0276	Birmingham 94'52	ED II/III?	5.1.2 5.7.4	-	-	Cii	314	B19	-	-	*
0277	Birmingham 93'52	ED II/III?	5.1.2 5.7.6?	-	-	Avi	-	-	-	-	*
0278	BM 1935-1-12, 122	ED II/III?	5.1.2	-	-	Aiii	-	-	-	-	*
5.1.3 Spouted jars: flat base, carinated shoulder											
0279	BM 1929-10-17, 697	ED II/III?	5.1.3 5.7.1	-	-	Avi	-	-	-	-	*
0280	BM 1929-10-10, 485 121755	ED II/III?	5.1.3 5.7.2	-	-	Aii	133	-	-	-	*
5.1.4 Spouted jars: flat base, round shoulder, tall											
0281	Birmingham 56'52	ED I?	5.1.4 5.7.3?	-	-	Avi	-	-	-	-	*

1
5
1

1	2	3	4	5	6	7	8	9	10	11	12
0282	Birmingham 38'52	ED I?	5.1.4 5.7.3	-	-	Avi	-	-	-	-	*
0283	Birmingham 188'52 1913-10-11, 274 114184	ED I?	5.1.4 5.7.3	-	-	Avi	-	-	-	-	*
5.1.6 Spouted jars: flat base, tall bottle-neck											
0284	BM 1933-10-13, 250	ED?	5.1.6 5.7.3	-	-	Avi	-	-	-	-	*
0285	BM 1930-12-13, 277 U14452	ED I?	5.1.6 5.7.4	-	-	Aiv	-	-	-	-	*
5.3 Spouted jars: ring base											
5.3.1 Spouted jars: ring base, plain rim											
0286	BM 1927-5-27, 272 U6451	ED II,III?	5.3.1 5.7.4	-	-	Avi	-	-	-	-	*
0287	BM 1928-10-10, 876 128547 U6451	ED II,III?	5.3.1 5.7.2	ED Graves	-	Avi	-	-	-	-	*
0288	BM 1928-10-10, 486 121756	ED II/III?	5.3.1 5.7.2	-	-	Aiii	-	-	-	-	*
0289	BM 1928-10-10, 631 121934	Akkad.	5.3.1 5.7.2	-	-	Aiii	-	-	-	-	*
5.3.2 Spouted jars: ring base, bevelled rim											
0290	BM 1930-12-13, 276	ED II/III	5.3.2 5.7.2	-	-	Biii	-	-	-	-	*
5.3.3 Spouted jars: ring base, carinated shoulder											
0291	BM 1928-10-10, 862 128533	ED II/III?	5.3.3 5.7.2	ED Tombs	-	Aiii	-	-	-	-	*
0292	BM 1928-10-10, 879 128550	ED II/III?	5.3.3 5.7.5	-	-	Aii	132	-	-	-	*

1	2	3	4	5	6	7	8	9	10	11	12
5.4 Spouted jars: pinched ring base											
5.4.1 Spouted jars: pinched ring base, flared rim											
0293	BM 1928-10-10, 487 121757	ED II/III?	5.4.1 5.7.2	-	-	Di	-	-	-	-	*
5.6 Spouted jars: other											
0294	BM 1928-10-10, 840 128511	E. Akkad.?	5.6 5.7.4	-	-	Avi	-	-	-	-	*
5.7 Spouted jar sherds: spouts											
5.7.1 Short spouts											
0295	Birmingham no acc.	ED	5.7.1	-	-	Aiii	277	-	13/6	-	-
6 <u>Wing-lugged jars</u>											
6.1 Small wing-lugged jars											
6.1.1 Small wing-lugged jars: plain lug											
0296	BM 1935-1-13, 593 138074	ED I?	6.1.1	-	-	Avi?	-	-	-	-	*
6.1.2 Small wing-lugged jars: perforated lug											
0297	BM 1935-1-13, 737 138318	ED I?	6.1.2	-	-	Bii	-	-	-	-	*
6.2 Wing-lugged jars: pinched ring base											
0298	BM 1935-1-12, 120	ED I?	6.2	-	-	Avi	-	-	-	-	*
0299	BM 1935-1-12, 119	ED I?	6.2	-	-	Avi	-	-	-	-	*
0300	BM 1935-1-12, 118 134624	ED I?	6.2	ED Tombs	-	Avi	-	-	-	-	*
0301	BM 1935-10-13, 247	ED I?	6.2	-	-	Aii	131	-	-	-	*
7 <u>Footed/Cup-based jars (Pedestal jars)</u>											
0302	BM 1935-1-13, 734 138315	Akkad.?	7	-	-	Ai	110	-	-	-	*

1	2	3	4	5	6	7	8	9	10	11	12	
8	<u>Body sherds (jars)</u>											
8.1	Rouletted decoration											
0303	Birmingham	no acc.	Uruk	8.1	-	-	Aii	275	B33	-	-	*
8.2	'Gouged' decoration											
0304	Birmingham	no acc.	Uruk	8.2	-	-	Ji	308	B61	12/19	-	*
8.3	Combed decoration											
0305	Birmingham	no acc.	L. Uruk?	8.3 8.6.3	-	-	Bii	285	B36	17/10	-	*
0306	Birmingham	no acc.	L. Uruk?	8.3 8.6.3	-	-	Ki	309	B63	12/13	51/12 51/13	*
0307	Birmingham	no acc.	L. Uruk?	8.3 8.8.1	-	-	Ii	307	-	12/26	51/16	*
0308	Birmingham	no acc.	L. Uruk?	8.3 8.8.1	-	-	Hi Hi	305 306	-	12/23	-	*
0309	Birmingham	no acc.	L. Uruk?	8.3 8.8.1	-	-	Gii	304	-	12/21	-	*
8.4	Lugged jar sherds											
8.4.1	Lugged jar sherds: lug perforated											
0310	Birmingham	no acc.	L. Uruk?	8.4.1.1 8.8.4 2.4.2.6	-	-	Ciii	318	B310	-	-	*
0311	Birmingham	no acc.	E. ED I?	8.4.1.3 2.4.2.6	-	-	Biii	287	-	12/32	-	*
0312	Birmingham	no acc.	E. ED I?	8.4.1.3 2.4.2.6	-	-	Biii	290	-	-	-	*
0313	Birmingham	no acc.	E. ED I?	8.4.1.3	-	-	Biii	288	B59	-	-	*
0314	Birmingham	no acc.	E. ED I?	8.4.1.3	-	-	Biii	282	B49	-	-	*
0315	Birmingham	no acc.	E. ED I?	8.4.1.3	-	-	Biii	291	-	12/33	-	*

1	2	3	4	5	6	7	8	9	10	11	12	
8.5 Incised decoration												
8.5.2 Incised decoration: cross-hatched												
0316	Birmingham	no acc.	ED	8.5.2	-	-	Ai	273	-	-	-	*
0317	Birmingham	no acc.	ED	8.5.2 8.5.7	-	-	Bii	280	-	13/4	-	*
0318	Birmingham	no acc.	ED	8.5.2 8.5.7	-	-	Biv	299	-	-	-	*
0319	Birmingham	no acc.	ED	8.5.2 8.5.7	-	-	Aii	268	-	-	-	*
0320	Birmingham	no acc.	ED	8.5.2 8.5.7	-	-	Aii	267	-	-	-	*
0321	Birmingham	no acc.	ED	8.5.2	-	-	Aiii	270	-	-	-	*
0322	Birmingham	no acc.	ED	8.5.2 8.5.7	-	-	Biii	289	-	-	-	*
0323	Birmingham	no acc.	ED	8.5.2 8.5.7	-	-	Biii	292	-	-	-	*
0324	Birmingham	no acc.	ED	8.5.2 8.5.7	-	-	Biii	293	-	-	-	*
0325	Birmingham	no acc.	ED	8.5.2 8.5.7	-	-	Biii	297	-	-	-	*
0326	Birmingham	no acc.	ED I?	8.5.2	-	-	Gi	303	-	12/15	51/10 51/11	*
0327	Birmingham	no acc.	ED	8.5.2	-	-	Biii	298	-	-	-	*
0328	Birmingham	no acc.	ED I/II?	8.5.2	-	-	Ei	300	-	-	-	*
0329	Birmingham	no acc.	ED	8.5.2 8.5.7	-	-	Bii	281	B50	-	-	*
0330	Birmingham	no acc.	ED	8.5.2 8.5.7	-	-	Biii	294	-	12/36	-	*

1	2	3	4	5	6	7	8	9	10	11	12
0331	Birmingham 333'55	ED	8.5.2 8.5.7	-	-	Dii	283	B15	13/11	-	*
0332	Birmingham no acc.	ED	8.5.2 8.5.7	-	-	Biii	286	B38	13/16	-	-
0333	Birmingham no acc.	ED	8.5.2 8.6.5	-	-	Biii	296	-	-	-	*
0334	Birmingham no acc.	ED	8.5.2 8.6.5	-	-	Biii	295	-	-	-	*
8.5.4 Incised decoration: herringbone											
0335	BM 1919-10-11, 2800	ED II?	8.5.4 8.5.7	-	-	Bi	161	-	11/11	52/19	*
8.7 Cut ware											
0336	Birmingham 499'62	ED I?	8.7 8.6.1 8.4.1.4 2.4.2.4	-	-	Aiii	278	-	-	-	*
8.7.1 Cut ware: ribbed with cross-hatched decoration and perforated lug											
0337	A 1953: 1334a	ED I	8.7.1 2.4.2.4	-	-	Aii	115	-	-	-	*
8.7.2 Cut ware with incised, cross-hatched decoration											
0338	A 1953: 1334b	ED I	8.7.2	-	-	Aii	116	-	-	-	*
0339	A 1953: 1334c	ED I	8.7.2 8.13.1	-	-	Ai	107	-	-	-	*
0340	A 1953: 1334d	ED I	8.7.2	-	-	Ai	108	-	-	-	*
0341	A 1953: 1334e	ED I	8.7.2	-	-	Aiv	-	-	-	-	*
0342	A 1953: 1334f	ED I	8.7.2	-	-	Aiv	-	-	-	-	*
0343	A 1953: 1334g	ED I	8.7.2	-	-	Aiv	-	-	-	-	*
0344	A 1953: 1334h	ED I	8.7.2	-	-	Aiv	-	-	-	-	*

1
53
1

1	2	3	4	5	6	7	8	9	10	11	12
8.8 Striated/grooved decoration (Tab-rim jars)											
8.8.1 Horizontal grooves											
0345	Birmingham	no acc.	ED I?	8.8.1 2.4.2.3	-	-	Aii	274	-	13/9	- *
0346	Birmingham	no acc.	ED I?	8.8.1 8.3	-	-	Aiii	272	-	16/6	- *
0347	Birmingham	no acc.	ED I?	8.8.1	-	-	Aii	269	-	-	- *
8.9 Reserve-slipped decoration											
8.9.1 Diagonal reserve slip											
0348	Birmingham	no acc.	ED I?	8.9.1 8.6.1	-	-	Aii	271	-	-	- *
0349	A 1953: 1334a		ED I?	8.9.1 5	-	-	Aii	114	-	13/19	- *
8.9.4 Diagonal-cross-horizontal reserve slip											
0350	A 1953: 1334		ED I/II	8.9.4 5	-	-	Aii	113	-	-	- *
8.12 Decorated ribs: notched/nicked											
8.12.1 Single rib with notched decoration											
0351	A 1953: 1334b		ED	8.12.1	-	-	Ai	-	A211	13/22	- *
0352	A 1953: 1334c		ED	8.12.1	-	-	Gi	-	-	-	- *
0353	A 1953: 1334d		ED II/III	8.12.1	-	-	Avi	-	-	13/26	- *
9 <u>Upright-handled jars</u>											
0354	BM 1935-1-13, 817 139470		ED II?	?9	-	Woolley 1934, 162; 388; 554 pl. 187	Avi	109	-	9/38 52/2	- *
10 <u>Stemmed dishes</u>											
10.1 Stemmed dishes: plain											

1	2	3	4	5	6	7	8	9	10	11	12
0355	BM 1935-1-12, 101	ED II/III	10.1	-	-	Aiii	-	-	-	-	*
10.1.1 Stemmed dishes: plain with perforated stem											
0356	BM 1935-1-13, 800 139453	ED II/III	10.1.1	-	Moon 1982, 57, fig. 10, no. 49	Avi	122	-	-	52/3	*
0357	BM 1935-1-13, 800 139453	ED II/III	10.7.1	-	Moon 1982, 57, fig. 10, no. 49	Avi	121	-	-	-	-
0358	BM 1935-1-13, 800 139453	ED II/III	10.8.1	-	Moon 1982, 57, fig. 10, no. 49	Avi	120	-	-	-	-
10.1.2 Stemmed dishes: notched ribs and perforated, fenestrated stem											
0359	BM 1935-1-13, 804 139457	ED II/III	10.1.2	-	Moon 1982, 57, fig. 10, no. 50	Avi	-	-	-	-	*
0360	BM 1919-10-11, 519	ED II/III	10.1.2 10.8.2	-	-	Aii	130	-	-	-	*
10.2 Stemmed dishes: incised, geometric decoration											
0361	BM 1935-1-13, 814 139467	ED II/III	10.2	-	-	Aii	124	-	-	-	*
0362	BM 1935-1-13, 813 139466	ED III?	10.2 10.8.4	-	-	Ci	145	-	9/23	-	*
0363	BM 1935-1-13, 812 139465	ED II/III	10.2 10.8.4	-	-	Ai	126	-	-	-	*
0364	BM 1935-1-13, 812 139465	ED III?	10.2 10.8.4	-	-	Ci	146	-	-	-	-
0365	BM 1935-1-13, 811 139464	ED III?	10.2 10.8.4	-	-	Ciii	170	-	11/14	52/23	*
0366	BM 1935-1-13, 802 139455	ED II/III	10.2	-	-	Aii	119	-	-	-	*
10.2.1 Stemmed dishes: incised, geometric decoration; ribbed and/or perforated											
0367	BM 1935-1-13, 805 139458	ED II/III	10.2.1 10.8.5	-	-	Bii	140	-	-	-	*
0368	BM 1935-1-13, 819 139472	ED III?	10.2.1 10.8.5	-	-	Ci	147	-	-	52/13	*
0369	BM 1935-1-13, 801 139454	ED II/III	10.2.1	-	-	Biv	142	-	9/3	52/7 52/8	*

1	2	3	4	5	6	7	8	9	10	11	12
0370	BM 1935-1-13, 798 139451	ED II/III	10.2.1 10.8.5	-	Moon 1982, 60, fig. 10, no. 52	Avii	-	-	-	-	*
0371	BM 1935-1-13, 816 139469	ED III?	10.2.1	-	-	Ciii	-	-	-	-	*
10.2.2 Stemmed dishes: incised, geometric decoration; ribbed											
0372	BM 1927-10-3, 278	ED II/III	10.2.2	PG 90	-	Aiv	129	-	-	-	*
10.2.3 Stemmed dishes: incised, geometric decoration; fenestrated											
0373	BM 1935-1-13, 799 139452	ED II/III	10.2.3	-	Moon 1982, 60, fig. 12, no. 57	Aiii Aiii	134 135	-	-	52/12	*
0374	BM 1935-1-13, 799 139452	ED II/III	10.2.3	-	-	Avi	-	-	-	-	*
10.3 Stemmed dishes: incised decoration; flora											
0375	BM 1935-1-13, 797 139450	ED III?	10.3	-	Moon 1982, 60, fig. 10, no. 53	Ciii	-	-	-	-	*
0376	BM 1935-1-13, 815 139468	ED II/III	10.3	-	-	Avi	125	-	9/19	-	*
10.3.1 Stemmed dishes: fenestrated, incised decoration; flora											
0377	BM 1927-10-3, 279 U2537	ED II/III	10.3.1	-	-	Avi	123	-	-	-	*
0378	BM 1928-10-10, 665 121968	ED II/III	10.3.1	PG 85	Woolley 1934, 534 Moon 1982, 60, fig. 11, no. 56	Ji	-	-	-	-	*
10.4 Stemmed dishes: incised decoration; flora, architecture and female attributes											
0379	BM 1928-10-10, 880 128551 U13709	ED I?	10.4	-	Woolley 1934, 388, pl. 218 Moon 1982, 60, fig. 12, no. 58	Diii?	173	-	10/25	-	*
10.5 Stemmed dishes: incised decoration; flora, fauna, architecture and/or female attributes											
0380	BM 1935-1-13, 792 139445	ED III?	10.5	-	Moon 1982, 60, fig. 12, no. 59	Ciii	156	-	-	52/16	*
0381	BM 1935-1-13, 794 139447	ED III?	10.5	-	Moon 1982, 60, fig. 10, no. 54	Ciii	151	-	10/17	-	*
0382	BM 1935-1-13, 792 139445	ED III?	10.5	-	Moon 1982, 60, fig. 12, no. 59	Eii	157	-	9/6	52/17	*
0383	BM 1935-10-10, 480 121750 U8536	ED II/III	10.5	PG 175	Woolley 1934, 534 Moon 1982, 60, fig. 11, no. 55	Ai	112	-	-	-	*

1	2	3	4	5	6	7	8	9	10	11	12
0384	BM 1935-1-13, 793 139446	ED III?	10.5	-	Moon 1982, 62, fig. 13, no. 60	Ciii	-	-	-	-	*
0385	BM 1935-1-13, 803 139456	ED III?	10.5	-	-	Ciii	155	-	11/9	-	*
0386	BM 1928-10-10, 479 121749	ED III?	10.5	PG 87	Woolley 1934, 414-415	Ciii	-	-	-	-	*
0387	A 1953: 1332 U15814	ED II/III	10.5	-	-	Di	167	A208	10/21	52/20	*
10.6	Stemmed dishes: plastic decoration added										
0388	BM 1935-1-13, 807 139460 U8245 (?)	ED II/III	10.6	-	c.f. Woolley 1934, 530; pl. 180b	Li	-	-	-	-	*
10.7	Stemmed dish rims										
10.7.1	Stemmed dish rims: plain										
0389	BM 1935-1-13, 810 139463	ED III?	10.7.1	-	-	Ciii	-	-	-	-	*
0390	BM 1935-1-13, 808 139461	ED III?	10.7.1	-	-	Ciii	153	-	-	52/15	*
0391	BM 1935-1-13, 808 139461	ED III?	10.7.1	-	-	Ciii	154	-	-	-	-
10.7.2	Stemmed dish rims: notched rib										
0392	BM 1935-1-13, 796 139449	ED III?	10.7.2	-	-	Ciii	-	-	-	-	*
10.7.3	Stemmed dish rims: notched rib and 'wavy-line' decoration										
0393	BM 1935-1-13, 809 139462	ED III?	10.7.3	-	-	Ciii	152	-	-	-	*
0394	BM 1935-1-13, 818 139471	ED II/III	10.7.3	-	-	Bi	160	-	10/19	52/18	*
11	<u>Hollow Stands</u>										
11.1	Small perforated stand ('wash-stand')										
0395	BM 1929-10-17, 719	ED	11.1	-	-	Aiv	-	-	-	-	*
11.2	Large hollow stands: plain										
0396	BM 1928-10-10, 481 121751	ED II/III	11.2	-	-	Di	-	-	-	-	*

1	2	3	4	5	6	7	8	9	10	11	12
0397	BM 1919-10-11, 4943	ED	11.2	-	-	Bv	-	-	-	-	-
0398	BM 1927-5-27, 269 118739	ED	11.2	-	-	Di Di	166 168	-	9/26 9/28	52/21 52/22	*
0399	BM 1919-10-11, 2793	ED	11.2	-	-	Di	165	-	-	-	*
0400	Birmingham no acc.	ED	11.2	-	-	Di	312	B16	-	-	*
0401	Birmingham no acc.	ED	11.2	-	-	Fii	311	B24	-	-	*
0402	Birmingham no acc.	ED	11.2	-	-	Fi	310	B25	12/2	51/14 51/15	*
12	<u>Miniatures</u>										
12.1	Miniatures: bowl/goblet										
0403	BM 1924-9-20, 137 116876 U1514	ED	12.1	-	-	Aii	-	-	-	-	*
12.3	Miniatures: 'bag-pot' or 'thumb-pot'										
0404	BM 1924-9-20, 139 116878 U1484	ED	12.3	-	-	Avi	-	-	-	-	*
0405	BM 1924-9-20, 135 116874 U1739	ED	12.3	-	-	Ciii	-	-	-	-	*
12.4	Miniatures: jars										
0406	BM 1928-10-10, 492 121762	ED	12.4	-	-	Biii	-	-	-	-	*
0407	BM 1919-10-11, ?	ED	12.4	-	-	Ai	-	-	-	-	*
0408	BM 1919-10-11, 375	ED	12.4	Tomb J	-	Ai	-	-	-	-	*
0409	BM 1924-9-20, 133 116872 U1480	ED	12.4 8.12.1	-	-	Eii	-	-	-	-	*
0410	BM 1924-9-20, 134 116873 U1479	Akkad. ?	12.4 13.3.4	-	-	Ci	-	-	-	-	*
0411	BM 1935-1-13, 392 137873 U14445	ED	12.4	-	-	Di?	-	-	-	-	*

I
S
I

1	2	3	4	5	6	7	8	9	10	11	12
0412	BM 1928-10-10, 875 128546	ED	12.4 8.5.2 8.12.1	-	-	Bii	-	-	-	-	*
12.4.2 Miniature jar with perforated shoulder-tabs											
0413	BM 1924-9-20, 132 116871 U1483	ED	12.4.2 8.5.2	-	-	Ciii	-	-	-	-	*
12.5 Miniature stand: perforated											
0414	BM 1928-10-10, 672 121975	ED	12.5	-	-	Di	-	-	-	-	*
13 <u>Painted ware</u> (body sherds)											
13.2 Painted ware: polychrome											
13.2.1 Polychrome: red on white slip											
0415	Birmingham no acc.	ED ?	13.2.1	-	-	Aiv	262	-	-	-	-
13.2.3 Polychrome: red and black on white slip											
0416	Birmingham no acc.	ED ?	13.2.3	-	-	Other :4	320	B123	-	51/8	-
0417	Birmingham no acc.	ED ?	13.2.3	-	-	Eii	321	B124	12/11	-	-
0418	Birmingham no acc.	ED ?	13.2.3	-	-	Aiv	263	-	-	-	-
TELL SAKHERI SUGHIR											
1 <u>Bowls</u>											
1.1 Conical bowls											
0419	SS A 049	ED I	1.1	Locus A	Wright 1969, 48-52, 125, tb.14	Bvii	182	-	-	-	-
0420	SS H 111	ED I	1.1	Locus H	Wright 1969, 48-52, 125, tb.14	Ei	183	-	-	-	-
0421	SS G 111	ED I	1.1	Locus G	Wright 1969, 48-52, 125, tb.14	Eiii	189	-	-	-	-

1	2	3	4	5	6	7	8	9	10	11	12
2	<u>Jars</u>										
2.1	Small jars										
0422	SS O 013	ED I	2.1	Locus O	Wright 1969, 48-52, 125, tb.14	Kii	192	-	-	-	-
0423	SS N 066	ED I	2.1	Locus N	Wright 1969, 48-52, 125, tb.14	Jii	194	-	-	-	-
0424	SS N 066	ED I	2.1	Locus N	Wright 1969, 48-52, 125, tb.14	Jii	195	-	-	-	-
0425	SS P 012	ED I	2.1	Locus P	Wright 1969, 48-52, 125, tb.14	Giii	191	-	-	-	-
0426	SS Q 081	ED I	2.1	Locus Q	Wright 1969, 48-52, 125, tb.14	Jii	193	-	-	-	-
0427	SS R 109	ED I	2.1	Locus R	Wright 1969, 48-52, 125, tb.14	Av	188	-	-	-	-
0428	SS S 012	ED I	2.1	Locus S	Wright 1969, 48-52, 125, tb.14	Aiv	187	-	-	-	-
2.3	Large jars										
0429	SS M 066	ED I	2.3	Locus M	Wright 1969, 48-52, 125, tb.14	Aii	185	-	-	-	-
0430	SS C 049	ED I	2.3	Locus C	Wright 1969, 48-52, 125, tb.14	Biv	186	-	-	-	-
0431	SS Y 080	ED I	2.1	Locus Y	Wright 1969, 48-52, 125, tb.14	Aii	184	-	-	-	-
8	<u>Body sherds (jars)</u>										
8.9	Reserve slipped decoration										
8.9.2	Horizontal reserve slip										
0432	SS E 066	ED I	8.9.2	-	Wright 1969, 48-52, 125, tb.14	Bii	190	-	-	-	-
	<u>Clay Samples</u>										
0433	SS J 107	-	Baked brick	Locus J	Wright 1969, 48-52, 125, tb.14	-	196	-	-	-	-
0434	SS K 107	-	Clay lump (baked)	Locus K	Wright 1969, 48-52, 125, tb.14	-	197	-	-	-	-

1	2	3	4	5	6	7	8	9	10	11	12
0435	SS L	-	Silt-clay (unfired)	Locus L	Wright 1969, 48-52, 125, tb.14	-	198	-	-	-	-
TELL AL UBAID											
1	<u>Bowls</u>										
1.1	Conical bowls										
0436	BM 1924-9-20, 348 T.O. 151 117085	ED III	1.1 rim > 15cm	Grave 40	Hall & Woolley 1927, 195, 207	Ai	-	-	-	-	*
0437	BM 1924-9-20, 459 T.O. 462	ED II/IIIA	1.1	Grave 80	Hall & Woolley 1927, 201, 212 Martin 1982, 174-175	Bi	-	-	-	-	*
0438	BM 1919-10-11, 2394	ED	1.1	-	-	Bii	-	-	-	-	*
0439	BM 1919-10-11, 2493	ED	1.1	-	-	Ci	-	-	-	-	*
0440	BM 1919-10-11, 2383 117973	ED	1.1	-	-	Ci	-	-	-	-	*
0441	BM 1919-10-11, 2384 117974	ED	1.1	-	-	Bii	-	-	-	-	*
0442	BM 1919-10-11, 2382 117972	ED	1.1	-	-	Ai	-	-	-	-	*
0443	BM 1919-10-11, 2397 (waster)	ED	1.1 14.1.1	-	-	Giii	-	-	-	-	*
0444	BM 1919-10-11, 2395 (waster)	ED	1.1	-	-	Giii	-	-	-	-	*
1.3	Goblets										
1.3.1	Footed goblets										
0445	BM 1924-9-20, 305 T.O. 227 117042	ED I/II	1.3.1	Grave 13	Hall & Woolley 1927, 191, 208	Av	-	-	-	-	*
0446	Birmingham 188'52	ED II/IIIA	1.3.1	-	-	Aiv	-	-	-	-	*

1	2	3	4	5	6	7	8	9	10	11	12
0447	BM 1924-9-20, 306 117043 T.O. 189	ED II/IIIA	1.3.1	-	Hall & Woolley 1927, 207	Aiv	-	-	-	-	*
0448	BM 1919-10-11, 2396	ED II/IIIA	1.3.1 14.1.1	-	-	Bii	204	-	-	-	*
1.3.2 Solid-footed goblets											
0449	BM 1924-9-20, 307 117044	ED I?	1.3.2 14.1.1	-	-	Aiv	-	-	-	-	*
1.14 Bowl rim sherds											
1.14.5 Bowl sherds: medium; dished rim											
0450	BM 1919-10-11, 2453	ED?	1.14.5.4	-	-	Aii	201	-	-	-	*
1.14.7 Bowl sherds: large rims											
0451	BM 1919-10-11, 2490	ED	1.14.7.2	-	-	Bi	205	-	9/33	51/3 51/4	*
0452	BM 1924-9-20, 411 117162 T.O. 505	ED I?	1.14.7.6.1	Grave 14	Hall & Woolley 1927, 191, 213	Aii	-	-	-	-	*
2 Jars											
2.1 Small jars											
2.1.1 Small jars: flat base (string-cut)											
0453	BM 1924-9-20, 312 117049 C. 10.13	ED I?	2.1.1.1	C.10	Hall & Woolley 1927, 190; pl. 44	Aiii	-	-	-	-	*
0454	BM 1924-9-20, 303 117040 C. 68.8	ED II/IIIA	2.1.1.1	C.68	Hall & Woolley 1927, 199	Aiii	-	-	-	-	*
0455	BM 1924-9-20, 344 117081 C. 89.8	ED II/IIIA	2.1.1.1	C.89	Hall & Woolley 1927, 202	Aiii	-	-	-	-	*
0456	BM 1924-9-20, 117052 C. 56.9	ED II/IIIA	2.1.1.1	C.56	Hall & Woolley 1927, 197; pl. 45	Lii	-	-	-	-	*

1	2	3	4	5	6	7	8	9	10	11	12
2.2 Medium jars											
2.2.2 Medium jars: flat base											
0457	BM 1924-9-20, 343 117080 T.O. 79	ED I?	2.2.2.5	Grave 12	Hall & Woolley 1927, 191; 205 Martin 1982, 168, tb.1a	Bii	-	-	-	-	*
0458	BM 1924-9-20, 342 117079 T.O. 459	ED I?	2.2.2.5	Grave 74	Hall & Woolley 1927, 203; 212 Martin 1982, 168, tb.1a	Aiv	-	-	-	-	*
0459	BM 1924-9-20, 339 117076 T.O. 470	Akkad. ?	2.2.2.7 2.4.6	-	Hall & Woolley 1927, 212	Avi	-	-	-	-	*
2.2.3 Medium jars: ring base											
0460	BM 1924-9-20, 336 117073	ED II/IIIA	2.2.3.2	-	-	Avi	-	-	-	-	*
2.3 Large jars											
2.3.1 Large jars: flat base											
0461	BM 1924-9-20, 297 117034	ED II/IIIA	2.3.1.1	-	Martin 1982, 169, tb.1b	Aiv	-	-	-	-	*
0462	BM 1924-9-20, 293 117030 T.O. 49	ED I	2.3.1.2	Grave 1	Hall & Woolley 1927, 189; 205; pl.43 Martin 1982, 169, tb.1b	Aiv	199	-	-	51/1	*
0463	BM 1924-9-20, 296 117033 T.O. 473	ED II/IIIA	2.3.1.3	-	Hall & Woolley 1927, 212	Aiv	-	-	-	-	*
0464	BM 1924-9-20, 334 117071	ED II/IIIA	2.3.1.3	-	-	Aii	-	-	-	-	*
2.3.2 Large jars: convex base											
0465	BM 1924-9-20, 335 117072 T.O. 165	ED II/IIIA	2.3.2.1	Grave 41	Hall & Woolley 1927, 195; 207 Martin 1982, 174-175, tb.5	Aiv	-	-	-	-	*
0466	BM 1924-9-20, 286 117023 T.O. 465	ED II/IIIA	2.3.2.4	Grave 88	Hall & Woolley 1927, 202; 212	Aii	-	-	-	-	*
0467	BM 1924-9-20, 294 117031 T.O. 476	ED I?	2.3.2.5	Grave 77	Hall & Woolley 1927, 200; 212 Martin 1982, 168, tb.1a	Aii	-	-	-	-	*
2.3.4 Large jars: ring base											
0468	BM 1924-9-20, 283 117020 T.O. 480	ED II/IIIA	2.3.4.2	Grave 80	Hall & Woolley 1927, 201; 212	Aiii	-	-	-	-	*

1	2	3	4	5	6	7	8	9	10	11	12
2.4 Jar rim sherds											
2.4.3 Jar rim sherds: long neck											
0469	BM 1919-10-11, 2447	ED	2.4.3.1	-	-	Div	209	-	9/16	-	*
2.4.5 Jar sherds: bevelled rim											
0470	BM 1919-10-11, 2358	ED	2.4.5.6	-	-	Bi	206	-	10/31	-	*
2.4.6 Jar sherds: collar/band rim											
0471	BM 1919-10-11, 2346	ED	2.4.6.5	-	-	Bi	207	-	-	-	*
0472	BM 1919-10-11, 2491	ED	2.4.6.6	-	-	Ci	208	-	-	51/5	*
2.4.8 Jar sherds: flat rim											
0473	BM 1919-10-11, 2352 (waster)	ED	2.4.8.3 8.6.1	-	-	Giii?	210	-	11/20	51/2	*
3 Bottles											
3.1 Bottles: bevelled rim											
0474	BM 1919-10-11, 2496 117951	ED	3.1	-	-	Aiii	-	-	-	-	*
0475	BM 1924-9-20, 322 117059 T.O. 89	ED II/IIIA	3.1	Grave 17	Hall & Woolley 1927, 191; 206 Martin 1982, 169, tb.1b	Aiv	-	-	-	-	*
0476	BM 1924-9-20, 320 117057 T.O. 120	ED II/IIIA	3.1	Grave 29	Hall & Woolley 1927, 193; 206	Aiv	-	-	-	-	*
0477	BM 1924-9-20, 319 117056 T.O. 457	ED II/IIIA	3.1	Grave 70	Hall & Woolley 1927, 199; 212	Eiii	-	-	-	-	*
3.3 Bottles: long neck											
0478	BM 1924-9-20, 324 117061 T.O. 75	ED II/IIIA	3.3	Grave 7	Hall & Woolley 1927, 190; 205	Avi	-	-	-	-	*
3.5 Bottles: carinated shoulder											
0479	BM 1924-9-20, 321 117058 T.O. 456	ED II?	3.5	Grave 6	Hall & Woolley 1927, 189; 212 Martin 1982, 169 tb.1b; 179, tb.6	Aii	-	-	-	-	*

1	2	3	4	5	6	7	8	9	10	11	12
4.1 'Drinking' bottles: double mouthed											
0480	BM 1924-9-20, 345 117082 T.O. 504	ED II/IIIA	4	Grave 86	Hall & Woolley 1927, 202; 213	Aiv	-	-	-	-	*
5 <u>Spouted jars</u>											
5.1 Spouted jars: flat base											
5.1.4 Spouted jars: flat base, round shoulder, tall											
0481	BM 1924-9-20, 300 117037 T.O. 48	ED I?	5.1.4	Grave 1	Hall & Woolley 1927, 189; 205; pl.43 Martin 1982, 168 tb.1a	Ai	-	-	-	-	*
5.1.5 Spouted jars: flat base, reserve slip decoration on shoulder											
0482	BM 1925-9-20, 282 117019 Tb 77	ED II?	5.1.5 8.9.2 5.7.3	Grave 10	Hall & Woolley 1927, 190; 205; pl.44	Aii	-	-	-	-	*
0483	BM 1924-9-20, 279 117016	ED II?	5.1.5 8.9.2	-	-	Aii	-	-	-	-	*
0484	BM 1924-9-20, 278 117015	ED I?	5.1.5 8.9.2	-	-	Avi	-	-	-	-	*
5.2 Spouted jars: convex base											
5.2.1 Spouted jars: convex base, rounded shoulder, tall (short spout)											
0485	BM 1924-9-20, 332 117069 T.O. 506	ED I?	5.2.1 5.7.1	Grave 88	Hall & Woolley 1927, 202; 213 Martin 1982, 168. tb.1a	Avi	-	-	-	-	*
5.2.2 Spouted jars: convex base, carinated shoulder											
0486	BM 1924-9-20, 292 117029 T.O. 502	ED II/IIIA	5.2.2 5.7.6	Grave 76	Hall & Woolley 1927, 200; 213	Avii	-	-	-	-	*
0487	BM 1924-9-20, 291 117028 C. 35.19	ED I?	5.2.2 5.7.6	Grave 35	Hall & Woolley 1927, 193-194	Aii	-	-	-	-	*
0488	BM 1919-10-11, 2492	ED I?	? 5.2.2	-	-	Aiii	202	-	-	-	*

1	2	3	4	5	6	7	8	9	10	11	12
5.3 Spouted jars: ring base											
5.3.3 Spouted jars: ring base, carinated shoulder											
0489	BM 1924-9-20, 287 117024 T.O. 500	ED II/IIIA	5.3.1 5.7.2 5.7.6	-	Hall & Woolley 1927, 213 Martin 1982, 179. tb.6	Aiv	-	-	-	-	*
5.4 Spouted jars: pinched ring base											
5.4.1 Spouted jars: pinched ring base, flared rim											
0490	BM 1924-9-20, 285 117022 C. 20.3	ED III	5.4.1 5.7.4	Grave 20	Hall & Woolley 1927, 191	Avii	-	-	-	-	*
5.4.3 Spouted jars: pinched ring base, ribbed shoulder carination											
0491	BM 1924-9-20, 413 T.O. 511	ED I?	5.4.3 8.6.1 8.9.4 8.12.1	Grave 88	Hall & Woolley 1927, 202; 213	Aiii	-	-	-	-	*
0492	BM 1924-9-20, 416	ED I?	5.4.3 8.5.5 8.12.1 5.7.3	-	-	Aiv	-	-	-	-	*
6 <u>Wing-lugged jars</u>											
6.2 Wing-lugged jars: pinched ring base											
0493	BM 1924-9-20, 333 117070 T.O. 510	ED I?	6.2 8.6.2.1	Grave 88	Hall & Woolley 1927, 202; 213 Martin 1982, 168, tb.1a	Ei	-	-	-	-	*
6.3 Large wing-lugged jars: added ring base (perforated lug)											
0494	BM 1924-9-20, 280 117017 T.O. 509	ED I?	6.3 8.6.1	Grave 74	Hall & Woolley 1927, 200; 213	Aii	-	-	-	-	*
8 <u>Body sherds (jars)</u>											
8.5 Incised decoration											
8.5.2 Incised decoration: cross-hatched											
0495	BM 1919-10-11, 1450 115389	ED III?	8.5.2	-	Hall & Woolley 1927, pl.19	Avii	200	-	-	51/6	*

1	2	3	4	5	6	7	8	9	10	11	12
8.9 Reserve-slipped decoration											
8.9.1 Diagonal reserve slip											
0496	BM 1919-10-11, 2343 121258	ED II/IIIA	8.9.1 8.6.1	-	Hall & Woolley 1927, pl.20	Aiv	-	-	-	-	*
8.12 Decorated ribs: notched/nicked											
8.12.1 Single rib with notched decoration											
0497	BM 1919-10-11, 1458 121249	ED III?	8.12.1	-	Hall & Woolley 1927, pl.19	Aii	-	-	-	-	*
0498	BM 1919-10-11, 2442	ED III?	8.12.1	-	-	Bii	203	-	-	-	*
11 <u>Hollow stands</u>											
11.2 Large hollow stands: plain											
0499	BM 1919-10-11, 2485	ED II/III?	11.2	-	-	Aiii	-	-	-	-	*
0500	BM 1919-10-11, 2484 115449	ED II/III?	11.2	-	-	Aiii	-	-	-	-	-
<u>Building materials</u>											
Door binding											
0501	BM 1919-10-11, 2808	-	-	-	-	-	-	-	-	-	*
ERIDU											
1 <u>Bowls</u>											
1.2 'Transitional' bowls											
0502	BM 1919-10-11, 4130 (waster)	ED II?	1.2	-	-	-	-	-	11/23	-	*
1.3 Goblets											
1.3.1 Footed goblets											
0503	BM 1919-11-11, 550 (waster)	ED I/II?	1.3.1 14.1.1	-	-	Ei?	214	-	-	-	*

1	2	3	4	5	6	7	8	9	10	11	12
0504	BM 1919-11-11, 552 (waster)	ED I/II?	1.3.1 14.1.1	-	-	Bii	180	-	-	-	*
0505	BM 1919-11-11, 551 (waster)	ED I/II?	1.3.1 14.1.1	-	-	-	181	-	-	-	*
0506	BM 1919-11-11, 953 (waster)	ED I/II?	1.3.1 14.1.1	-	-	-	179	-	9/13	-	*
Bevel-rim bowl (BRB)											
0507	BM 1919-10-11, 4028	Uruk	BRB	-	-	Aii	-	-	-	-	*
2	<u>Jars</u>										
2.1	Small jars										
2.1.1	Small jars: flat base (string-cut)										
0508	BM 1919-10-11, 4055	ED	2.1.1.2.1	-	-	Bii	-	-	-	-	*
2.4	Jar rim sherds										
2.4.4	Jar sherds: rolled rim										
0509	BM 1919-10-11, 4403	ED	2.4.4.2	-	-	Bii	213	-	-	-	*
2.4.6	Jar sherds: collar/band rim										
0510	BM 1919-10-11, 4625	ED	2.4.6.1	-	-	Bii	-	-	-	-	*
10	<u>Stemmed dishes</u>										
10.8	Stemmed dish bases										
10.8.2	Stemmed dish bases: ribbed										
0511	BM 1919-10-11, 4621	ED	? 10.8.1	-	-	Ai	211 212	-	9/35	51/7	*

1	2	3	4	5	6	7	8	9	10	11	12
LAGASH											
1	<u>Bowls</u>										
1.1	Conical bowls										
0512	Iraq Museum	no acc.	ED I?	1.1 14.1.1	-	-	Ai	-	-	-	*
1.14	Bowl rim sherds										
1.14.6	Bowl sherds with rim										
0513	Iraq Museum	no acc.	L. ED III?	1.14.6.9	-	-	Aii	215"	-	7/30	*
2	<u>Jars</u>										
2.4	Jar rim sherds										
2.4.6	Jar sherds: collar/band rim										
0514	Iraq Museum	no acc.	ED	2.4.6.1	-	-	Aiii	216	-	-	*
10	<u>Stemmed dishes</u>										
10.8	Stemmed dish bases										
10.8.2	Stemmed dish bases: ribbed										
0515	Iraq Museum	no acc.	ED	10.8.2	-	-	Aiii	-	-	8/3	*
WARKA (URUK)											
1	<u>Bowls</u>										
1.1	Conical bowls										
0516	Iraq Museum	no acc.	ED?	1.1	-	-	Aiv	221	-	7/5	*
9	<u>Upright handled jars</u>										
0517	Iraq Museum	no acc.	ED II?	? 9 8.5.1	-	-	Bi	224	-	7/6	*

1	2	3	4	5	6	7	8	9	10	11	12	
10	<u>Stemmed dishes</u>											
10.7	Stemmed dish rims											
10.7.2	Stemmed dish rims: notched rib and 'wavy' line											
0518	Iraq Museum	no acc.	ED II/III?	10.7.2	-	-	Ci Ci	222 223	-	-	-	*
FARA												
1	<u>Bowls</u>											
1.1	Conical bowls											
0519	Fara survey		ED III?	1.1	Surface	-	Bi	230	-	-	-	*
0520	Fara survey		ED III?	1.1 13.1.1	Surface	-	Ai	229	-	-	-	*
1.3	Goblets											
1.3.1	Footed goblets											
0521	Fara survey		ED I?	1.3.1	Surface	-	Aiv	228	-	-	-	*
0522	Fara survey		ED I?	1.3.1 14.1.1	Surface	-	Bi	231	-	-	-	*
1.3.2	Solid footed goblets											
0523	Fara survey		ED I?	1.3.2 14.1.1	Surface	-	Bi	232	-	-	-	-
1.14	Bowl rim sherds											
1.14.8	Vertical-sided bowls											
0524	Fara survey		ED II/III?	1.14.8.5	Surface	-	Aii	227	-	-	-	*

1	2	3	4	5	6	7	8	9	10	11	12	
2	<u>Jars</u>											
2.1	Small jars											
2.1.1	Small jars: flat base (string-cut)											
0525	Iraq Museum	no acc.	ED III?	2.1.1.1	-	-	Ai	-	-	-	-	*
2.4	Jar rim sherds											
2.4.1	Jar rim sherds: hole-mouthed											
0526	Fara survey		ED I/II?	2.4.1.4	Surface	-	Bi	233	-	-	-	*
2.4.6	Jar sherds: collar/band rim											
0527	Fara survey		ED III?	2.4.6.2	Surface	-	Aiii	225	-	-	-	*
8	<u>Body sherds (jars)</u>											
8.12	Decorated ribs: notched/nicked											
0528	Fara survey		ED III?	8.12.1	Surface	-	Aiii	226	-	7/9	-	*
NIPPUR												
2	<u>Jars</u>											
2.4	Jar rim sherds											
2.4.6	Jar sherds: collar/band rim											
0529	Iraq Museum	no acc.	ED III?	2.4.6.7	-	-	Aiv	236	-	-	-	*
10	<u>Stemmed dishes</u>											
10.8	Stemmed dish bases											
10.8.2	Stemmed dish bases: ribbed											
0530	Iraq Museum	no acc.	ED	10.8.2	-	-	-	234	-	-	-	*

1	2	3	4	5	6	7	8	9	10	11	12	
11	<u>Hollow stands</u>											
11.3	Hollow stands: ribbed											
0531	Iraq Museum	no acc.	ED	11.3	-	-	A	235	-	-	-	*
ABU SALABIKH: MAIN MOUND, AREA E												
1	<u>Bowls</u>											
1.1	Conical bowls											
0532	0054	(11)	ED IIIA	1.1	6G 64b	-	-	-	-	-	-	-
0533	0055	(28)	ED	1.1	6G 64b	-	-	-	-	-	-	-
0534	0208	(34)	L. ED III	1.1	6G 65d	-	-	-	-	-	-	-
0535	0209	(1)	ED	1.1	6G 65c	-	-	-	-	-	-	-
0536	0304	(1)	ED	1.1	6G 55d	-	-	-	-	-	-	-
0537	0306	(25)	ED III	1.1	6G 55a	-	-	-	-	-	-	-
0538	0354	(7)	ED IIIA/B	1.1	6G 55a	-	-	-	-	-	-	-
0539	0355	(1)	ED III	1.1	6G 55d	-	-	-	-	-	-	-
0540	0357	(50)	ED III	1.1	6G 55d	-	-	-	-	-	-	-
0541	0403	(2)	ED III	1.1	6G 66	-	-	-	-	-	-	-
0542	0404	(94)	ED IIIB	1.1	6G 66	-	-	-	-	-	-	-
0543	0507	(107)	ED III	1.1	6G 37b	-	-	-	-	-	-	-
0544	0509	(26)	ED III	1.1	6G 37c	-	-	-	-	-	-	-
0545	0584	(1)	ED III	1.1	6G 37a	-	Aii	329	-	-	-	-
0546	0584	(20)	ED III	1.1	6G 37a	-	Aii	-	-	-	-	-

1	2	3	4	5	6	7	8	9	10	11	12
0547	0584	(16)	ED III	1.1	6G 37a	-	Aiii	-	-	-	-
0548	0584	(23)	ED III	1.1	6G 37a	-	Aiv	-	-	-	-
0549	0584	(7)	ED III	1.1	6G 37a	-	Av	-	-	-	-
0550	0584	(6)	ED III	1.1	6G 37a	-	Avi	-	-	-	-
0551	0584	(6)	ED III	1.1	6G 37a	-	Avii	-	-	-	-
0552	0584	(7)	ED III	1.1	6G 37a	-	Bi	-	-	-	-
0553	0584	(4)	ED III	1.1	6G 37a	-	Ci	-	-	-	-
0554	0584	(2)	ED III	1.1	6G 37a	-	Cii	-	-	-	-
0555	0611	(46)	ED III	1.1	6G 74b	-	-	-	-	-	-
0556	0614	(22)	ED IIIA	1.1	6G 74b	-	-	-	-	-	-
0557	1804	(6)	ED III	1.1	6G 85c	-	Aii	-	-	-	-
0558	1804	(13)	ED III	1.1	6G 85c	-	Aiii	-	-	-	-
0559	1804	(1)	ED III	1.1	6G 85c	-	Aiv	-	-	-	-
0560	1804	(3)	ED III	1.1	6G 85c	-	Av	-	-	-	-
0561	1804	(2)	ED III	1.1	6G 85c	-	Avi	-	-	-	-
0562	1804	(1)	ED III	1.1	6G 85c	-	Avii	-	-	-	-
0563	1804	(6)	ED III	1.1	6G 85c	-	Bi	-	-	-	-
0564	1804	(2)	ED III	1.1	6G 85c	-	Ci	-	-	-	-
0565	1804	(1)	ED III	1.1	6G 85c	-	Cii	-	-	-	-
0566	1804	(2)	ED III	1.1 rim > 15cm	6G 85c	-	Di	-	-	-	-
0567	1805: 6G 85: 43		ED III	1.1 rim > 15cm	6G 85c	-	Ciii	-	-	-	*

I
83
I

1	2	3	4	5	6	7	8	9	10	11	12
0568	1805: 6G 85: 32	ED III	1.1	6G 85c	-	Cii	-	-	-	-	*
0569	1805: 6G 85: 48	ED III	1.1	6G 85c	-	Aiii	-	-	-	-	*
0570	1805 (1)	ED III	1.1	6G 85c	-	Ai	-	-	-	-	-
0571	1805 (6)	ED III	1.1	6G 85c	-	Aii	-	-	-	-	-
0572	1805 (15)	ED III	1.1	6G 85c	-	Aiii	-	-	-	-	-
0573	1805 (3)	ED III	1.1	6G 85c	-	Aiv	-	-	-	-	-
0574	1805 (1)	ED III	1.1	6G 85c	-	Av	-	-	-	-	-
0575	1805 (1)	ED III	1.1	6G 85c	-	Avi	-	-	-	-	-
0576	1805 (1)	ED III	1.1	6G 85c	-	Avii	-	-	-	-	-
0577	1805 (12)	ED III	1.1	6G 85c	-	Bi	-	-	-	-	-
0578	1805 (4)	ED III	1.1	6G 85c	-	Bii	-	-	-	-	-
0579	1805 (1)	ED III	1.1	6G 85c	-	Di	-	-	-	-	-
0580	1809: 6G 85: 51	ED III	1.1	6G 85b	-	Ciii	-	-	-	-	-
0581	1809 (2)	ED III	1.1	6G 85b	-	Ai	-	-	-	-	-
0582	1809 (7)	ED III	1.1	6G 85b	-	Aii	-	-	-	-	-
0583	1809 (13)	ED III	1.1	6G 85b	-	Aiii	-	-	-	-	-
0584	1809 (5)	ED III	1.1	6G 85b	-	Aiv	-	-	-	-	-
0585	1809 (3)	ED III	1.1	6G 85b	-	Av	-	-	-	-	-
0586	1809 (1)	ED III	1.1	6G 85b	-	Avi	-	-	-	-	-
0587	1809 (2)	ED III	1.1	6G 85b	-	Avii	-	-	-	-	-
0588	1809 (3)	ED III	1.1	6G 85b	-	Bii	-	-	-	-	-

1	2	3	4	5	6	7	8	9	10	11	12
0589	1809	(1)	ED III	1.1	6G 85b	-	Bii	-	-	-	-
0590	1809	(5)	ED III	1.1	6G 85b	-	Ciii	-	-	-	-
0591	2235	(9)	ED IIIA/B	1.1	6G 62a	-	-	-	-	-	-
0592	2420	(4)	ED III	1.1	6G 36d	-	Aii	-	-	-	-
0593	2420	(8)	ED III	1.1	6G 36d	-	Aiii	-	-	-	-
0594	2420	(12)	ED III	1.1	6G 36d	-	Aiv	-	-	-	-
0595	2420	(2)	ED III	1.1	6G 36d	-	Av	-	-	-	-
0596	2420	(6)	ED III	1.1	6G 36d	-	Bi	-	-	-	-
0597	2420	(2)	ED III	1.1	6G 36d	-	Cii	-	-	-	-
0598	2440	(345)	ED IIIB?	1.1	6G 36a	-	-	-	-	-	-
0599	2701	(1)	ED II/IIIA	1.1	6G 64b	-	Aii	-	-	-	-
0600	2701	(4)	ED II/IIIA	1.1	6G 64b	-	Aiii	-	-	-	-
0601	2701	(11)	ED II/IIIA	1.1	6G 64b	-	Aiv	-	-	-	-
0602	2701	(4)	ED II/IIIA	1.1	6G 64b	-	Bi	-	-	-	-
0603	2701	(1)	ED II/IIIA	1.1	6G 64b	-	Ciii	-	-	-	-
0604	2701	(1)	ED II/IIIA	1.1	6G 64b	-	Di	-	-	-	-
0605	2729	(6)	ED II	1.1	6G 64b	-	Ai	-	-	-	-
0606	2729	(61)	ED II	1.1	6G 64b	-	Aii	-	-	-	-
0607	2729	(81)	ED II	1.1	6G 64b	-	Aiii	-	-	-	-
0608	2729	(96)	ED II	1.1	6G 64b	-	Aiv	-	-	-	-
0609	2729	(31)	ED II	1.1	6G 64b	-	Av	-	-	-	-

1	2	3	4	5	6	7	8	9	10	11	12	
0610	2729	(43)	ED II	1.1	6G 64b	-	Avii	-	-	-	-	-
0611	2729	(89)	ED II	1.1	6G 64b	-	Bi	-	-	-	-	-
0612	2729	(13)	ED II	1.1	6G 64b	-	Biv	-	-	-	-	-
0613	2729	(54)	ED II	1.1	6G 64b	-	Cii	-	-	-	-	-
0614	2729	(72)	ED II	1.1	6G 64b	-	Ciii	-	-	-	-	-
0615	2785	(4)	ED IB	1.1	6G 64b	-	Aii	-	-	-	-	-
0616	2785	(7)	ED IB	1.1	6G 64b	-	Aiii	-	-	-	-	-
0617	2785	(7)	ED IB	1.1	6G 64b	-	Aiv	-	-	-	-	-
0618	2785	(3)	ED IB	1.1	6G 64b	-	Bi	-	-	-	-	-
0619	2785	(1)	ED IB	1.1	6G 64b	-	Bii	-	-	-	-	-
0620	2785	(12)	ED IB	1.1	6G 64b	-	Cii	-	-	-	-	-
0621	2792	(1)	ED IB	1.1	6G 64b	-	Aii	-	-	-	-	-
0622	2792	(4)	ED IB	1.1	6G 64b	-	Aiii	-	-	-	-	-
0623	2792	(5)	ED IB	1.1	6G 64b	-	Aiv	-	-	-	-	-
0624	2792	(6)	ED IB	1.1	6G 64b	-	Bi	-	-	-	-	-
0625	2792	(8)	ED IB	1.1	6G 64b	-	Cii	-	-	-	-	-
0626	2792	(6)	ED IB	1.1	6G 64b	-	Ciii	-	-	-	-	-
0627	3203	(8)	L. ED I	1.1	6G 64b	-	-	-	-	-	-	-
0628	3205	(11)	L. ED I	1.1	6G 64b	-	-	-	-	-	-	-
0629	3215	(2)	L. ED I	1.1	6G 64b	-	Cii	-	-	-	-	-
0630	3215	(1)	L. ED I	1.1	6G 64b	-	Aiv	-	-	-	-	-

1	2	3	4	5	6	7	8	9	10	11	12
0631	3222	(2)	ED II	1.1	6G 64b	-	Aiv	-	-	-	-
0632	3222	(1)	ED II	1.1	6G 64b	-	Bii	-	-	-	-
0633	3222	(3)	ED II	1.1	6G 64b	-	Cii	-	-	-	-
0634	3223	(1)	ED II	1.1	6G 64b	-	Aiii	-	-	-	-
0635	3223	(5)	ED II	1.1	6G 64b	-	Aiv	-	-	-	-
0636	3223	(8)	ED II	1.1	6G 64b	-	Cii	-	-	-	-
0637	3229	(1)	L. ED I	1.1	6G 64b	-	Ci	-	-	-	-
0638	3237	(3)	L. ED I	1.1	6G 64b	-	Bii	-	-	-	-
0639	3237	(7)	L. ED I	1.1	6G 64b	-	Cii	-	-	-	-
0640	3237	(1)	L. ED I	1.1	6G 64b	-	Di	-	-	-	-
0641	3238	(1)	L. ED I	1.1	6G 64b	-	Aiii	-	-	-	-
0642	6000	: 6F05:29	ED III	1.1	6F 05b	-	Bii	-	-	-	*
0643	6000	: 6F05:23	ED III	1.1	6F 05b	-	Bii	-	-	-	*
0644	6000	(19)	ED III	1.1	6F 05b	-	Aii	-	-	-	-
0645	6000	(54)	ED III	1.1	6F 05b	-	Avi	-	-	-	-
0646	6000	(17)	ED III	1.1	6F 05b	-	Bii	-	-	-	-
0647	6000	(31)	ED III	1.1	6F 05b	-	Cii	-	-	-	-
"Grosse blumentopf"											
0648	0304		ED	-	6G 55d	-	Eii	-	-	-	-
0649	2792		ED IB	1.1	6G 64d	-	Eii	-	-	-	-

1	2	3	4	5	6	7	8	9	10	11	12
1.2 Transitional bowls											
1.2.1 Transitional bowls: cut rim											
0650	0354	ED IIIA/B	1.2.1	6G 55a	-	Di	-	-	-	-	-
0651	2729 (2)	ED II	1.2.1	6G 64b	-	Bii	-	-	-	-	-
0652	2792	ED IB	1.2.1	6G 64b	-	Bii	-	-	-	-	-
0653	3203	L. ED I	1.2.1 13.3.1	6G 64b	-	Bii	-	-	-	-	-
0654	3223	ED II	1.2.1	6G 64b	-	Bii	-	-	-	-	-
0655	6000 (2)	ED III	1.2.1	6F 05b	-	Bix	-	-	-	-	-
Bevel-rim bowls (BRB)											
0656	2792	ED IB	BRB	6G 64b	-	Ni	-	-	-	-	-
0657	3205	L. ED I	BRB	6G 64b	-	Niii	-	-	-	-	-
0658	3237	L. ED I	BRB	6G 64b	-	Niii	-	-	-	-	-
1.7 Ring-based bowls											
1.7.1 Ring-based bowls: large											
0659	1805 : 6G 85:31	ED III	1.7.1	6G 85c	-	Avi	-	-	-	-	*
0660	1809 : 6G 85:72	ED III	1.7.1	6G 85b	-	Li	-	-	-	-	*
1.9 Sieve bowls											
1.9.2 Sieve bowls: round base											
0661	0054	ED IIIA	1.9.2?	6G 64b	-	Aiii	-	-	-	-	-
0662	2792	ED IB	1.9.2?	6G 64b	-	Aiv	-	-	-	-	-
0663	3222	ED II	1.9.2	6G 64b	-	Bi	-	-	-	-	-

1
88
1

1	2	3	4	5	6	7	8	9	10	11	12
1.14 Bowl rim sherds											
1.14.1 Bowl sherds: fine; plain rim											
0664	0611	ED III	1.14.1.1	6G 74b	-	Aiv	-	-	-	-	-
0665	1805	ED III	1.14.1.1	6G 85c	-	Bi	-	-	-	-	-
0666	0404	ED IIIB	1.14.1.2	6G 66	-	Aiii	-	-	-	-	-
1.14.2 Bowl sherds: fine; rolled rim											
0667	0306	ED III	1.14.2.1	6G 55a	-	Aii	-	-	-	-	-
0668	0584	ED III	1.14.2.1	6G 37a	-	Avi Avi	332 333	584D	-	-	*
0669	1804	ED III	1.14.2.1	6G 85c	-	Aiv	-	-	-	-	-
0670	1809	ED III	1.14.2.1	6G 85c	-	Lii	-	-	-	-	-
0671	3223	ED II	1.14.2.1	6G 64b	-	Cii	-	-	-	-	-
1.14.3 Bowl sherds: medium; plain rim											
0672	0584	(2)	ED III	1.14.3.1	6G 37a	-	Aiii	-	-	-	-
0673	0584		ED III	1.14.3.1	6G 37a	-	Li	-	-	-	-
0674	1804		ED III	1.14.3.1	6G 85c	-	Ciii	-	-	-	-
0675	2701		ED II/IIIA	1.14.3.1	6G 64b	-	Di	-	-	-	-
0676	2729	(3)	ED II	1.14.3.1	6G 64b	-	-	-	-	-	-
0677	2792		ED IB	1.14.3.1	6G 64b	-	Aiii	-	-	-	-
0678	3203		L. ED I	1.14.3.1	6G 64b	-	Eii	-	-	-	-
0679	2440		ED IIIB?	1.14.3.1 .1	6G 36a	-	Cii	-	-	-	-
0680	2729		ED II	1.14.3.3	6G 64b	-	Ei	-	-	-	-

I
68
I

1	2	3	4	5	6	7	8	9	10	11	12
0681	0357	ED III	1.14.3.4	6G 55d	-	Aii	-	-	-	-	-
0682	0611	ED III	1.14.3.4	6G 74b	-	Cii	-	-	-	-	-
0683	2729	ED II	1.14.3.4	6G 64b	-	Avi	-	-	-	-	-
1.14.4 Bowl sherds; medium; cut rim											
0684	0584	ED III	1.14.4.1	6G 37a	-	Aii	-	-	-	-	-
0685	0584	ED III	1.14.4.1	6G 37a	-	Ci	-	-	-	-	-
0686	2729	ED II	1.14.4.1	6G 64b	-	Avi	-	-	-	-	-
0687	3203	L. ED I	1.14.4.1 13.3.1	6G 64b	-	Biii	-	-	-	-	-
1.14.5 Bowl sherds: medium; dished rim											
0688	0208	L. ED III	1.14.5.1	6G 65c	-	Cii	-	-	-	-	-
0689	0357	(2)	ED III	1.14.5.1	6G 55d	-	Cii	-	-	-	-
0690	0404	ED IIIB	1.14.5.1	6G 66	-	Cii	-	-	-	-	-
0691	0404	ED IIIB	1.14.5.1	6G 66	-	Bi	-	-	-	-	-
0692	0404	(2)	ED IIIB	1.14.5.1	6G 66	-	Cii	-	-	-	-
0693	1809	ED III	1.14.5.1	6G 85b	-	Aii	-	-	-	-	-
0694	2729	(2)	ED II	1.14.5.1	6G 64b	-	Aiv	-	-	-	-
0695	2729	ED II	1.14.5.2	6G 64b	-	Avi	-	-	-	-	-
0696	2792	ED IB	1.14.5.3	6G 64b	-	Eii	-	-	-	-	-
1.14.6 Bowl sherds: medium; bevelled/everted rim											
0697	0404	ED IIIB	1.14.6.1	6G 66	-	Av	-	-	-	-	-
0698	0404	ED IIIB	1.14.6.1	6G 66	-	Cii	-	-	-	-	-

1	2	3	4	5	6	7	8	9	10	11	12
0699	2440		ED IIIB?	1.14.6.1	6G 36a	-	Aii	-	-	-	-
0700	2440		ED IIIB?	1.14.6.1	6G 36a	-	Di	-	-	-	-
0701	2729	(2)	ED II	1.14.6.1	6G 64b	-	Aiv	-	-	-	-
0702	2440		ED IIIB?	1.14.6.2	6G 36a	-	Aii	-	-	-	-
0703	2440		ED IIIB?	1.14.6.2	6G 36a	-	Aiv	-	-	-	-
0704	3222		ED II	1.14.6.2	6G 64b	-	Bii	-	-	-	-
0705	6000		ED III	1.14.6.2	6F 05b	-	Li	-	-	-	-
0706	0507		ED III	1.14.6.3	6G 37b	-	Aiii	326	507	-	-
0707	0508		ED IIIA?	1.14.6.3	6G 37c	-	Cii	-	-	-	-
0708	2440	(2)	ED IIIB?	1.14.6.3	6G 36a	-	Aiii	-	-	-	-
0709	2729	(2)	ED II	1.14.6.3	6G 64b	-	Avi	-	-	-	-
0710	3223		ED II	1.14.6.3	6G 64b	-	Ei	-	-	-	-
0711	2701		ED II/IIIA	1.14.6.5	6G 64b	-	Di	-	-	-	-
0712	2785		ED IB	1.14.6.5	6G 64b	-	Di	-	-	-	-
0713	2785		ED IB	1.14.6.5	6G 64b	-	Aiv	-	-	-	-
0714	2440		ED IIIB?	1.14.6.6	6G 36a	-	Biii	347	2440J	-	*
0715	2440	(4)	ED IIIB?	1.14.6.6	6G 36a	-	Aiv	-	-	-	-
0716	2440	(3)	ED IIIB?	1.14.6.6	6G 36a	-	Cii	-	-	-	-
0717	3223		ED II	1.14.6.8	6G 64b	-	Eii	-	-	-	-
0718	2729	(3)	ED II	1.14.6.8 1.16.5	6G 64b	-	Di	-	-	-	-
0719	6000	(4)	ED III	1.14.6.9	6F 05b	-	Ciii	-	-	-	-

1	2	3	4	5	6	7	8	9	10	11	12
1.14.7 Bowl sherds: large rim											
0720	0404	(2)	ED IIIB	1.14.7.1	6G 66	-	Aiii	-	-	-	-
0721	0404	(2)	ED IIIB	1.14.7.1	6G 66	-	Cii	-	-	-	-
0722	3223		ED II	1.14.7.1	6G 64b	-	Ei	-	-	-	-
0723	3223		ED II	1.14.7.1	6G 64b	-	Bi	-	-	-	-
0724	0137		ED II	1.14.7.2	6G 54c	-	Eii	-	-	-	*
0725	0584		ED III	1.14.7.2	6G 37a	-	Ciii	-	-	-	-
0726	0584		ED III	1.14.7.2	6G 37a	-	Bii	-	-	-	-
0727	1809		ED III	1.14.7.2	6G 85b	-	Ciii	-	-	-	-
0728	2729		ED II	1.14.7.2	6G 64b	-	Ei	-	-	-	-
0729	2440	(2)	ED IIIB?	1.14.7.2.1	6G 36a	-	Aiv	-	-	-	-
0730	0055		ED IIIA	1.14.7.2.1 1.16.3	6G 64	-	Pi	-	-	-	-
0731	2729		ED II	1.14.7.2.1 1.16.3	6G 64b	-	Ni	-	-	-	-
0732	0208	(2)	L. ED III	1.14.7.2 'Well-type'	6G 65d	-	-	-	-	-	-
0733	2729		ED II	1.14.7.2.2 1.16.3	6G 64b	-	Nii	-	-	-	-
0734	0209		ED	1.14.7.3	6G 65c	-	-	-	-	-	-
0735	0404	(3)	ED IIIB	1.14.7.3	6G 66	-	Aiii	-	-	-	-
0736	0404		ED IIIB	1.14.7.3	6G 66	-	Bi	-	-	-	-
0737	0507		ED III	1.14.7.3	6G 37b	-	Aiii	-	-	-	-
0738	0611		ED III	1.14.7.3	6G 37a	-	Biii	-	-	-	-

1	2	3	4	5	6	7	8	9	10	11	12
0739	2729		ED II	1.14.7.3	6G 64b	-	Ei	-	-	-	-
0740	0304	(2)	ED	1.14.7.3.1	6G 55d	-	-	-	-	-	-
0741	0507	(3)	ED III	1.14.7.3.1	6G 37b	-	-	-	-	-	-
0742	2729	(2)	ED II	1.14.7.3.1 1.16.3	6G 64b	-	Niv	-	-	-	-
0743	1805		ED III	1.14.7.3.2	6G 85c	-	Di	-	-	-	-
0744	0507		ED III	1.14.7.5	6G 37b	-	Aiv	-	-	-	-
0745	1809		ED III	1.14.7.5.1	6G 85b	-	Bi	-	-	-	-
0746	2729		ED II	1.14.7.5.2 1.16.3	6G 64b	-	Ni	-	-	-	-
0747	3203		L. ED I	1.14.7.6 1.15.1	6G 64b	-	Eii	-	-	-	-
0748	2729	(2)	ED II	1.14.7.6.1 1.16.3	6G 64b	-	Biii	-	-	-	-
0749	2440	(2)	ED IIIB?	1.14.7.7	6G 36a	-	Cii	-	-	-	-
1.14.8 Vertical-sided bowls											
0750	0306		ED III	1.14.8.1	6G 55a	-	Bvi	327	-	-	*
0751	2440		ED IIIB?	1.14.8.6	6G 36a	-	Aii	-	-	-	-
0752	2420		ED III	1.14.8.6.1	6G 36d	-	Bii	-	-	-	-
0753	0584		ED III	1.14.8.8.1	6G 37a	-	Aiv	-	-	-	-
1.15 Large bowl sherds: coarse ware rims											
0754	0304		ED	1.15	6G 55d	-	-	-	-	-	-
0755	0306	(2)	ED III	1.15	6G 55a	-	-	-	-	-	-

1	2	3	4	5	6	7	8	9	10	11	12
0756	0357		ED III	1.15	6G 55d	-	-	-	-	-	-
0757	0584		ED III	1.15	6G 37a	-	Qv	-	-	-	-
0758	0616		ED III	1.15	6G 74b	-	-	-	-	-	-
0759	2420		ED III	1.15	6G 36d	-	Qi	-	-	-	-
0760	2440		ED IIIB?	1.15	6G 36a	-	Qii	-	-	-	-
0761	0584	(3)	ED III	1.15.1	6G 37a	-	Qv	-	-	-	-
0762	2420		ED III	1.15.1	6G 36d	-	Qiii	-	-	-	-
0763	6000		ED III	1.15.1	6F 05b	-	Qii	-	-	-	-
0764	0507		ED III	1.15.2	6G 37b	-	-	-	-	-	-
0765	3222	(2)	ED II	1.15.3	6G 64b	-	Qv	-	-	-	-
0766	0357		ED III	1.15.3 8.6.7	6G 37b	-	-	-	-	-	-
0767	0584		ED III	1.15.4	6G 37a	-	Qiii	-	-	-	-
0768	2729	(2)	ED II	1.15.4	6G 64b	-	Qv	-	-	-	-
0769	6000		ED III	1.15.4.1 13.3.2	6F 05b	-	Qi	-	-	-	-
0770	1809		ED III	1.15.5.1	6G 85c	-	Qi	-	-	-	-
0771	0584		ED III	1.15.6 13.3.3	6G 37a	-	Qii	-	-	-	-
0772	2729	(2)	ED II	1.15.6.1 1.16.3	6G 64b	-	Qv	-	-	-	-
1.15.9 Bowl sherds: coarse ware, shallow dish											
0773	1805		ED III	-	6G 85c	-	Qiii	-	-	-	-
0774	2420		ED III	1.15.9	6G 36d	-	Qiii	-	-	-	-

1	2	3	4	5	6	7	8	9	10	11	12
1.15.10 Bowl sherds: coarse ware rims, decorated rib											
0775	0507	ED III	-	6G 37b	-	-	-	-	-	-	-
0776	0509	ED III	-	6G 37c	-	-	-	-	-	-	-
2 Jars											
2.1 Small jars											
2.1.1 Small jars: flat base (string cut)											
0777	1809 : 6G 85:5	ED III	2.1.1.1	6G 85b	-	Aiv	-	-	-	-	-
0778	6000 : 6F 05:16	ED III	2.1.1.1	6G 05b	-	Aiv	-	-	-	-	*
2.1.2 Small jars: round base											
0779	6000 : 6F 05:27	ED III	2.1.2.2	6G 05b	-	Aiii	-	-	-	-	*
2.2 Medium jars											
2.2.1 Medium jars: round base											
0780	1804 : 6F 85:25	ED III	2.2.1.3 2.4.8.5	6G 85c	-	Bi	-	-	-	-	*
0781	1804 : 6G 85:28	ED III	2.2.1.3 2.4.8.5	6G 85c	-	Ciii	-	-	-	-	-
0782	1804 : 6G 85:1	ED III	2.2.1.3 2.4.8.5	6G 85c	-	Bi	-	-	-	-	-
0783	6000 : 6F 05:22	ED III	2.2.1.3 2.4.8.5	6F 05b	-	Ci	-	-	-	-	*
2.3 Large jars											
2.3.4 Large jars: ring base											
0784	6000 : 6F 05:51	ED III	2.3.4.1 2.4.3.2	6F 05b	-	Ciii	-	-	-	-	-

1	2	3	4	5	6	7	8	9	10	11	12
2.4 Jar rim sherds											
2.4.1 Jar rim sherds: hole-mouthed											
0785	1809		ED III	2.4.1.1	6G 85b	-	Ci	-	-	-	-
0786	3238		L. ED I	2.4.1.1	6G 64b	-	Mii	-	-	-	-
0787	1804		ED III	2.4.1.2	6G 85c	-	Bii	-	-	-	-
0788	1805		ED III	2.4.1.2	6G 85c	-	Ci	-	-	-	-
0789	1809		ED III	2.4.1.2	6G 85b	-	Aii	-	-	-	-
0790	1809	(3)	ED III	2.4.1.2	6G 85b	-	Biii	-	-	-	-
0791	2729	(2)	ED II	2.4.1.2	6G 64b	-	Miii	-	-	-	-
0792	2729		ED II	2.4.1.2	6G 64b	-	Jii	-	-	-	-
0793	6000		ED III	2.4.1.2	6F 05b	-	Mv	-	-	-	-
0794	0611		ED III	2.4.1.4	6G 74b	-	Ci	-	-	-	-
0795	2729	(2)	ED II	2.4.1.4	6G 64b	-	Miv	-	-	-	-
0796	0404		ED IIIB	2.4.1.6	6G 66	-	Biii	-	-	-	-
2.4.2 Jar rim sherds: short neck											
0797	0304		ED	2.4.2.1	6G 55d	-	Aii	-	-	-	-
0798	0306	(2)	ED III	2.4.2.1	6G 55a	-	Aiv	-	-	-	-
0799	0356		ED III	2.4.2.1	6G 55d	-	Bi	-	-	-	-
0800	0404	(2)	ED IIIB	2.4.2.1	6G 66	-	Diii	-	-	-	-
0801	0611		ED III	2.4.2.1	6G 74b	-	Aiii	-	-	-	-
0802	1804		ED III	2.4.2.1	6G 85c	-	Bii	-	-	-	-

1	2	3	4	5	6	7	8	9	10	11	12	
0803	1805		ED III	2.4.2.1	6G 85c	-	Aiv	-	-	-	-	
0804	3626		ED IIIA/B	2.4.2.1	6G 75a	-	Mvi	356	-	25/20	-	*
0805	6000		ED III	2.4.2.1	6G 85b	-	Miv	-	-	-	-	
0806	0357		ED III	2.4.2.2	6G 55d	-	Cii	-	-	-	-	
0807	1804		ED III	2.4.2.2	6G 85c	-	Biii	-	-	-	-	
0808	3222	(2)	ED II	2.4.2.2	6G 64b	-	Aiii	-	-	-	-	
0809	0404	(2)	ED IIIB	2.4.2.3	6G 66	-	Aiii	-	-	-	-	
0810	2729		ED II	2.4.2.5	6G 64b	-	Miii	-	-	-	-	
0811	2792		ED IB	2.4.2.5	6G 64b	-	Jii	-	-	-	-	
0812	2440		ED IIIB?	2.4.2.6	6G 36a	-	Aiii	-	2440G	-	-	*
0813	2440		ED IIIB?	2.4.2.6	6G 36a	-	Biii	-	-	-	-	
2.4.3 Jar rim sherds: long neck												
0814	0137		ED II	2.4.3.1	6G 54c	-	Biii	-	-	-	-	*
0815	0354	(2)	ED IIIA/B	2.4.3.1	6G 55a	-	Aiii	-	-	-	-	
0816	0404		ED IIIB	2.4.3.1	6G 66	-	Aiii	-	-	-	-	
0817	0404	(3)	ED IIIB	2.4.3.1	6G 66	-	Aiv	-	-	-	-	
0818	0507	(2)	ED III	2.4.3.1	6G 37b	-	Aii	-	-	-	-	
0819	0507		ED III	2.4.3.1	6G 37b	-	Aiii	-	-	-	-	
0820	0507		ED III	2.4.3.1	6G 37b	-	Bi	-	-	-	-	
0821	0507	(2)	ED III	2.4.3.1	6G 37b	-	Ci	-	-	-	-	
0822	0508		ED IIIA?	2.4.3.1	6G 37b	-	Li	-	-	-	-	

1	2	3	4	5	6	7	8	9	10	11	12
0823	0509		ED III	2.4.3.1	6G 37c	-	Bii	-	-	-	-
0824	0584	(2)	ED III	2.4.3.1	6G 37a	-	Aiv	-	-	-	-
0825	0584		ED III	2.4.3.1	6G 37a	-	Bi	-	-	-	-
0826	0584		ED III	2.4.3.1	6G 37a	-	Ci	-	-	-	-
0827	0611		ED III	2.4.3.1	6G 74b	-	Aii	-	-	-	-
0828	0611	(2)	ED III	2.4.3.1	6G 74b	-	Bi	-	-	-	-
0829	0611		ED III	2.4.3.1	6G 74b	-	Ci	-	-	-	-
0830	0614		ED IIIA	2.4.3.1	6G 74b	-	Ci	-	-	-	-
0831	1805		ED III	2.4.3.1	6G 85c	-	Ciii	-	-	-	-
0832	2440	(3)	ED IIIIB?	2.4.3.1	6G 36a	-	Aii	-	-	-	-
0833	2440		ED IIIIB?	2.4.3.1	6G 36a	-	Aiv	-	-	-	-
0834	2729	(2)	ED II	2.4.3.1	6G 64b	-	Avi	-	-	-	-
0835	2729		ED II	2.4.3.1	6G 64b	-	Bii	-	-	-	-
0836	3222		ED II	2.4.3.1	6G 64b	-	Ai	-	-	-	-
0837	3223		ED II	2.4.3.1	6G 64b	-	Aiii	-	-	-	-
0838	6000		ED III	2.4.3.1	6F 05b	-	Aii	-	-	-	-
0839	6000	(2)	ED III	2.4.3.1	6F 05b	-	Ci	-	-	-	-
0840	6000		ED III	2.4.3.1	6F 05b	-	Ciii	-	-	-	-
0841	0404		ED IIIIB	2.4.3.2	6F 66	-	Di	-	-	-	-
0842	0404	(3)	ED IIIIB	2.4.3.2	6F 66	-	Ciii	-	-	-	-
0843	1235		ED IIIIB	2.4.3.2	5I:11	-	Bi	-	1235I	-	*

1	2	3	4	5	6	7	8	9	10	11	12
0844	1805: 1805:	6G 85: 42 6G 85: 49	ED IIIB ED IIIB	2.4.3.2 2.4.3.2 2.3.4	6G 85c 6G 85c	- -	Bi Bi	- -	- -	- -	- *
0845	2440		ED IIIB?	2.4.3.2	6G 36a	-	Aii	-	-	-	-
0846	2440		ED IIIB?	2.4.3.2	6G 36a	-	Li	-	-	-	-
0847	2729	(2)	ED II	2.4.3.2	6G 64b	-	Ai	-	-	-	-
0848	2729		ED II	2.4.3.2	6G 64b	-	Ci	-	-	-	-
0849	3222		ED II	2.4.3.2	6G 64b	-	Aiv	-	-	-	-
0850	3223		ED II	2.4.3.2	6G 64b	-	Biii	-	-	-	-
0851	6000		ED III	2.4.3.4	6F 05b	-	Bi	-	-	-	-
0852	1235		ED IIIB	2.4.3.7	5I:11	-	Aiv	-	1235c	-	-
2.4.4 Jar sherds: rolled rim											
0853	0507		ED III	2.4.4.1	6G 37b	-	Bi	-	-	-	-
0854	0508		ED IIIA?	2.4.4.1	6G 37c	-	Aii	-	-	-	-
0855	2440		ED IIIB?	2.4.4.1	6G 36a	-	Aiv	-	-	-	-
0856	2729	(2)	ED II	2.4.4.1	6G 64b	-	Eii	-	-	-	-
0857	0404		ED IIIB	2.4.4.2	6G 66	-	Av	-	-	-	-
0858	0404	(2)	ED IIIB	2.4.4.2	6G 66	-	Bi	-	-	-	-
0859	1805		ED III	2.4.4.2	6G 85c	-	Ciii	-	-	-	-
0860	2440	(2)	ED IIIB?	2.4.4.2	6G 36a	-	Aiii	-	-	-	-
0861	2440		ED IIIB?	2.4.4.2	6G 36a	-	Ci	-	-	-	-
0862	2440	(2)	ED IIIB?	2.4.4.2	6G 36a	-	Aiv	-	-	-	-
0863	2440		ED IIIB?	2.4.4.2	6G 36a	-	Biii	-	-	-	-

1	2	3	4	5	6	7	8	9	10	11	12
0864	0584	(2)	ED III	2.4.4.2.1	6G 37a	-	Aiv	-	-	-	-
0865	0584		ED III	2.4.4.2.1	6G 37a	-	Bi	-	-	-	-
2.4.5 Jar sherds: bevelled rim											
0866	0404	(2)	ED IIIB	2.4.5.1	6G 66	-	Aiii	-	-	-	-
0867	0509		ED III	2.4.5.1	6G 37c	-	Aiii	-	-	-	-
0868	0584		ED III	2.4.5.1	6G 37a	-	Aiv	-	-	-	-
0869	0584		ED III	2.4.5.1	6G 37a	-	Bii	-	-	-	-
0870	0611		ED III	2.4.5.1	6G 74b	-	Ci	-	-	-	-
0871	1235		ED IIIB	2.4.5.1	5I:11	-	Cii	-	1235F	-	*
0872	2792		ED IB	2.4.5.1	6G 64b	-	Ei	-	-	-	-
0873	2436		ED IIIB?	2.4.5.1 13.1.1	6G 36a	-	Ei	340	-	24/7	*
0874	2792		ED II	2.4.5.3	6G 64b	-	Di	-	-	-	-
0875	0055		ED	2.4.5.4	6G 64	-	-	-	-	-	-
0876	0403		ED III	2.4.5.4	6G 66	-	Bii	-	-	-	-
0877	1235		ED IIIB	2.4.5.4	5I:11	-	Aii	-	1235G	-	*
0878	1804		ED III	2.4.5.4	6G 85c	-	Biii	-	-	-	-
0879	1804	(2)	ED III	2.4.5.4	6G 85c	-	Ciii	-	-	-	-
0880	1809		ED III	2.4.5.4	6G 85b	-	Li	-	-	-	-
0881	2440	(3)	ED IIIB?	2.4.5.4	6G 36a	-	Aiv	-	-	-	-
0882	2440	(2)	ED IIIB?	2.4.5.4	6G 36a	-	Biii	-	-	-	-
0883	2440		ED IIIB?	2.4.5.4	6G 36a	-	Cii	-	-	-	-

1	2	3	4	5	6	7	8	9	10	11	12
0884	6000 : 6F 05:21	ED III	2.4.5.4 2.3.2	6F 05b	-	Lii	-	-	-	-	*
0885	1235	ED IIIB	2.4.5.4 8.6.1	5I:11	-	Lii	-	1235A	-	-	*
0886	1804	ED III	2.4.5.4.1	6G 85c	-	Aii	-	-	-	-	-
0887	1235	ED IIIB	2.4.5.5	5I:11	-	Aii	-	1235H	-	-	*
0888	1805	ED III	2.4.5.5	6G 85c	-	Aiv	-	-	-	-	-
0889	1805	ED III	2.4.5.5	6G 85c	-	Bi	-	-	-	-	-
0890	6000 : 6F 05:6	ED III	2.4.5.5 8.9.2 2.3.4	6F 05b	-	Cii	-	-	-	-	*
0891	0507	ED III	2.4.5.5.1	6G 37b	-	Av	-	-	-	-	-
0892	1804	ED III	2.4.5.5.1	6G 85c	-	Aii	-	-	-	-	-
0893	1809	ED III	2.4.5.5.1	6G 85b	-	Di	-	-	-	-	-
0894	2440	ED IIIB?	2.4.5.5.1	6G 36a	-	Bi	352	2440D	-	50/1	*
0895	2440	ED IIIB?	2.4.5.5.1	6G 36a	-	Aiv	345	-	-	-	*
0896	2440	ED IIIB?	2.4.5.5.1	6G 36a	-	Av	349	2440I	-	-	*
0897	0209	ED	2.4.5.6	6G 65c	-	-	-	-	-	-	-
0898	0357	ED III	2.4.5.6	6G 55d	-	Cii	-	-	-	-	-
0899	0404 (3)	ED IIIB	2.4.5.6	6G 66	-	Aiii	-	-	-	-	-
0900	0404	ED IIIB	2.4.5.6	6G 66	-	Bi	-	-	-	-	-
0901	0404	ED IIIB	2.4.5.6	6G 66	-	Bii	-	-	-	-	-
0902	0507 (2)	ED III	2.4.5.6	6G 37b	-	Cii	-	-	-	-	-
0903	1235	ED IIIB	2.4.5.6	5I:11	-	Li	-	1235E	-	-	*
0904	1235	ED IIIB	2.4.5.6	5I:11	-	Bi	-	1235D	-	-	*

1	2	3	4	5	6	7	8	9	10	11	12	
0905	2711		ED III	2.4.5.6 13.2.1 13.2.8	6G 64b	-	Bvii	355	-	23/24	-	*
2.4.6 Jar sherds: collar/band rim												
0906	0304		ED	2.4.6.1	6G 55d	-	Aii	-	-	-	-	-
0907	0357	(2)	ED III	2.4.6.1	6G 55d	-	Av	-	-	-	-	-
0908	0404	(3)	ED IIIB	2.4.6.1	6G 66	-	Aiv	-	-	-	-	-
0909	0509	(2)	ED III	2.4.6.1	6G 37c	-	Bi	-	-	-	-	-
0910	0584	(9)	ED III	2.4.6.1	6G 37a	-	Aiv	-	-	-	-	-
0911	0584	(4)	ED III	2.4.6.1	6G 37a	-	Bi	-	-	-	-	-
0912	0584	(6)	ED III	2.4.6.1	6G 37a	-	Bii	-	-	-	-	-
0913	0584		ED III	2.4.6.1	6G 37a	-	Li	-	-	-	-	-
0914	1804		ED III	2.4.6.1	6G 85c	-	Biii	-	-	-	-	-
0915	1804	(2)	ED III	2.4.6.1	6G 85c	-	Cii	-	-	-	-	-
0916	1805	: 6G 85: 38	ED III	2.4.6.1 2.3.4	6G 85c	-	Aiv	-	-	-	-	*
0917	1805		ED III	2.4.6.1	6G 85c	-	Cii	-	-	-	-	-
0918	1809		ED III	2.4.6.1	6G 85c	-	Aii	-	-	-	-	-
0919	1809		ED III	2.4.6.1	6G 85c	-	Bi	-	-	-	-	-
0920	2440	(2)	ED IIIB?	2.4.6.1	6G 36a	-	Bi	-	-	-	-	-
0921	2440		ED IIIB?	2.4.6.1	6G 36a	-	Ci	-	-	-	-	-
0922	2729	(5)	ED II	2.4.6.1	6G 64b	-	Aiv	-	-	-	-	-
0923	2729	(4)	ED II	2.4.6.1	6G 64b	-	Biii	-	-	-	-	-
0924	2729	(2)	ED II	2.4.6.1	6G 64b	-	AV	-	-	-	-	-

1	2	3	4	5	6	7	8	9	10	11	12
0925	2785	(2)	ED IB	2.4.6.1	6G 64b	-	Ei	-	-	-	-
0926	2785		ED IB	2.4.6.1	6G 64b	-	Jii	-	-	-	-
0927	2792	(2)	ED IB	2.4.6.1	6G 64b	-	Bi	-	-	-	-
0928	6000		ED III	2.4.6.1	6F 05b	-	Aii	-	-	-	-
0929	6000		ED III	2.4.6.1	6F 05b	-	Cii	-	-	-	-
0930	0137		ED II	2.4.6.2	6G 54c	-	Aiv	337	-	-	*
0931	2792		ED IB	2.4.6.2	6G 64b	-	Jii	-	-	-	*
0932	6000		ED III	2.4.6.2	6F 05b	-	Jii	-	-	-	-
0933	0354	(2)	ED IIIA/B	2.4.6.3	6G 55a	-	Aii	-	-	-	-
0934	0354	(2)	ED IIIA/B	2.4.6.3	6G 55a	-	Bi	-	-	-	-
0935	0354		ED IIIA/B	2.4.6.3	6G 55a	-	Li	-	-	-	-
0936	2440		ED IIIB?	2.4.6.3	6G 36a	-	Bi	353	-	-	-
0937	2440		ED IIIB?	2.4.6.6	6G 36a	-	Bi	351	2440H	-	*
0938	6000	: 6F 05: 75	ED III	2.4.6.6	6F 05b	-	Ci	-	-	-	*
0939	2440		ED IIIB?	2.4.6.7	6G 36a	-	Aiv	350	-	-	*
0940	0357		ED III	2.4.6.7.1	6G 55d	-	Ci	-	-	-	-
2.4.7 Jar sherds: collar/band rim; dished/grooved											
0941	0055	(2)	ED	2.4.7.1	6G 64	-	-	-	-	-	-
0942	0137		ED II	2.4.7.1	6G 54c	-	Ei	-	-	-	*
0943	0304		ED	2.4.7.1	6G 55d	-	Diii	-	-	-	-
0944	0584		ED III	2.4.7.1	6G 37a	-	Bi	-	-	-	-

1	2	3	4	5	6	7	8	9	10	11	12
0945	1804	ED III	2.4.7.1	6G 85c	-	Aii	-	-	-	-	-
0946	1805	ED III	2.4.7.1	6G 85c	-	Aii	-	-	-	-	-
0947	2729	ED II	2.4.7.1	6G 64b	-	Aiv	-	-	-	-	-
0948	6000	ED III	2.4.7.1	6F 05b	-	Ci	-	-	-	-	-
0949	2078	-	2.4.7.1 8.20	-	-	Bi	-	-	-	-	*
0950	0354	ED IIIA/B	2.4.7.3	6G 55a	-	-	-	-	-	-	-
0951	2729	ED II	2.4.7.3	6G 64b	-	Aiv	-	-	-	-	-
0952	2729	ED II	2.4.7.3	6G 64b	-	Dii	-	-	-	-	-
0953	2729	(2)	ED II	2.4.7.3	6G 64b	Ei	-	-	-	-	-
0954	3203	L. ED I	2.4.7.3	6G 64b	-	Jii	-	-	-	-	-
0955	2420	ED III	2.4.7.4	6G 36d	-	Aii	-	-	-	-	-
0956	2729	(3)	ED II	2.4.7.4	6G 64b	Av	-	-	-	-	-
0957	2729	ED II	2.4.7.4	6G 64b	-	Bi	-	-	-	-	-
0958	2729	ED II	2.4.7.4	6G 64b	-	Ei	-	-	-	-	-
0959	3205	L. ED I	2.4.7.4	6G 64b	-	Bv	-	-	-	-	-
0960	1804	(2)	ED III	2.4.7.5	6G 85c	Bii	-	-	-	-	-
0961	2440	ED IIIB?	2.4.7.5	6G 36a	-	Li	-	-	-	-	-
0962	3223	(2)	ED II	2.4.7.5	6G 64b	Diii	-	-	-	-	-
0963	0354	ED IIIA/B	2.4.7.6	6G 55a	-	Aiv	-	-	-	-	-
0964	0357	ED III	2.4.7.6	6G 55d	-	Ci	-	-	-	-	-

1	2	3	4	5	6	7	8	9	10	11	12
2.4.8 Jar sherds: flat rim											
0965	0614		ED IIIA	2.4.8.1	6G 74b	-	Aii	-	-	-	-
0966	2729	(3)	ED II	2.4.8.2	6G 64b	-	Bi	-	-	-	-
0967	2729		ED II	2.4.8.2	6G 64b	-	Ei	-	-	-	-
0968	2792		ED IB	2.4.8.3	6G 64b	-	Jii	-	-	-	-
0969	3223		ED II	2.4.8.3	6G 64b	-	Ei	-	-	-	-
0970	0306		ED III	2.4.8.3.1	6G 55a	-	Aiv	-	-	-	-
0971	3223		ED II	2.4.8.4.1	6G 64b	-	Diii	-	-	-	-
0972	0404		ED IIIIB	2.4.8.5	6G 66	-	Aii	-	-	-	-
0973	6000		ED III	2.4.8.5	6F 05b	-	Aiv	-	-	-	-
0974	2440		ED IIIIB?	2.4.8.6	6G 36a	-	Aii	341	2440F	-	50/3 *
2.4.9 Jar sherds: coarse ware rims											
0975	2875		ED IB	2.4.9.2	6G 64b	-	Gi	-	-	-	-
0976	3203		L. ED I	2.4.9.2	6G 64b	-	Dii	-	-	-	-
0977	3222		ED II	2.4.9.2	6G 64b	-	Eii	-	-	-	-
0978	3223		ED II	2.4.9.2	6G 64b	-	Aiv	-	-	-	-
0979	1805	: 6G 85 : 46	ED III	2.4.9.4	6G 85c	-	Bi	-	-	-	*
0980	2420		ED III	2.4.9.4	6G 36d	-	Ci	-	-	-	-
3 Bottles											
0981	0584		ED III	3	6G 37a	-	Mi	-	-	-	-

1	2	3	4	5	6	7	8	9	10	11	12
5	<u>Spouted jars (sherds)</u>										
0982	1804	ED III	5 2.4.3.1	6G 85c	-	Bi	-	-	-	-	-
0983	0055	ED	5 2.4.7.1	6G 64	-	-	-	-	-	-	-
5.5	Spouted jar sherds: nipple-lug(s) on shoulder										
0984	0584	ED III	5.5	6G 37a	-	Aiv	-	-	-	-	-
5.7	Spouted jar sherds: spouts										
5.7.1	Short spouts										
0985	0404	(3)	ED IIIB	5.7.1	6G 66	-	Avii	-	-	-	-
0986	0508		ED IIIA?	5.7.1	6G 37c	-	Bvi	-	-	-	-
0987	0584	(4)	ED III	5.7.1	6G 37a	-	Avii	-	-	-	-
0988	0584		ED III	5.7.1	6G 37a	-	Ciii	-	-	-	-
0989	1235		ED IIIB	5.7.1	5I:11	-	Aiv	-	1235B	-	*
0990	2440	(3)	ED IIIB?	5.7.1	6G 36a	-	Bii	-	-	-	-
0991	2729	(6)	ED II	5.7.1	6G 64b	-	Avi	-	-	-	-
0992	2729		ED II	5.7.1	6G 64b	-	Jii	-	-	-	-
0993	2785		ED IB	5.7.1	6G 64b	-	Eii	-	-	-	-
0994	3222		ED II	5.7.1	6G 64b	-	Bvi	-	-	-	-
0995	3223		ED II	5.7.1 13.3.5	6G 64b	-	Avi	-	-	-	-
0996	1804		ED III	5.7.1.1	6G 85c	-	Aiv	-	-	-	-
0997	1809		ED III	5.7.1.1	6G 85b	-	Aiv	-	-	-	-

1	2	3	4	5	6	7	8	9	10	11	12
0998	6000	ED III	5.7.1.1	6F 05b	-	Ciii	-	-	-	-	-
5.7.2 Long spouts											
0999	0354	ED IIIA/B	5.7.2	6G 55a	-	Bvi	-	-	-	-	-
1000	0356	ED III	5.7.2	6G 55d	-	Aiv	-	-	-	-	-
1001	0357	ED III	5.7.2	6G 55d	-	Avii	-	-	-	-	-
1002	2420	ED III	5.7.2	6G 36d	-	Avii	-	-	-	-	-
1003	2792	ED IB	5.7.2	6G 64b	-	Eii	-	-	-	-	-
1004	6000	ED III	5.7.2	6F 05b	-	Avii	-	-	-	-	-
5.7.3 Conical spouts											
1005	0357	ED III	5.7.3	6G 55d	-	Avii	-	-	-	-	-
1006	3216	L. ED I	5.7.3 8.9.2 8.6.1	6G 64b	-	Jii	-	-	-	-	*
5.7.4 Upswept spouts											
1007	1809	ED III	5.7.4	6G 85b	-	Avii	-	-	-	-	-
5.7.8 Plugged spouts											
1008	0508	ED IIIA?	5.7.8	6G 37c	-	Bv	-	-	-	-	-
6 Wing-lugged jars											
6.1 Small wing-lugged jars											
6.1.1 Small wing-lugged jars: plain lug											
1009	1809 : 6G 85 : 67	ED III	6.6.1 8.9.2	6G 85b	-	Lii	-	-	-	-	*

1	2	3	4	5	6	7	8	9	10	11	12
6.2 Wing-lugged jars: pinched ring base											
1010	1809 : 6G 85 : 66	ED III	6.2 8.9.2 14.3.1	6G 85b	-	Li	-	-	-	-	*
1011	1809 : 6G 85 : 68	ED III	6.2 8.9.2 14.3.4	6G 85b	-	Aiv	-	-	-	-	*
1012	1809 : 6G 85 : 65	ED III	6.2 8.9.2 14.3.4	6G 85b	-	Aiv	-	-	-	-	*
7 <u>Footed/Cup-based jars (Pedestal jars)</u>											
1013	0507 (18)	ED III	7 2.4.7.1	6G 37b	-	-	-	-	-	-	-
1014	0509	ED IIIA?	7 2.4.7.1	6G 37c	-	Aiii	-	-	-	-	-
1015	0507	ED III	7 2.4.8.5	6G 37b	-	Aii	-	-	-	-	-
1016	0611 (2)	ED III	7 2.4.8.7	6G 74b	-	Aii	-	-	-	-	-
8 <u>Body sherds (jars)</u>											
8.3 Combed decoration											
8.3.1 Combed decoration: horizontal lines											
1017	2420	ED III	8.3.1	6G 36d	-	Bi	-	-	-	-	-
8.4 Lugged jar sherds											
1018	0357	ED III	8.4	6G 55d	-	Bi	-	-	-	-	-
1019	0507	ED III	8.4	6G 37b	-	Bii	-	-	-	-	-
1020	0611	ED III	8.4	6G 74b	-	Aii	334	-	14/35	-	-
1021	3203	L. ED I	8.4 8.9.4	6G 64b	-	Gii	-	-	-	-	-

1	2	3	4	5	6	7	8	9	10	11	12
8.4.1 Lugged jar sherds: lug perforated											
1022	2420	ED III	8.4.1.1	6G 36d	-	Aiii	-	-	-	-	-
8.4.2 Lugged jar sherds: plain lug											
1023	0584	ED III	8.4.2	6G 37a	-	Ciii	-	-	-	-	-
1024	0584	ED III	8.4.2	6G 37a	-	Lii	-	-	-	-	-
1025	2420	ED III	8.4.2.1 13.1.1	6G 36d	-	Aiv	-	-	-	-	-
8.5 Incised decoration											
1026	0208	L. ED III	8.5	6G 65d	-	Avi	-	-	-	-	-
1027	0354	ED IIIA/B	8.5	6G 55d	-	Mi	-	-	-	-	-
1028	0354	(2)	ED IIIA/B	6G 55d	-	Biv	-	-	-	-	-
1029	0507	ED III	8.5	6G 37b	-	Bi	-	-	-	-	-
1030	0507	ED III	8.5	6G 37b	-	Aiv	-	-	-	-	-
1031	0508	ED IIIA?	8.5	6G 37c	-	Ciii	-	-	-	-	-
1032	2440	ED IIIB?	8.5	6G 36a	-	Aiv	-	-	-	-	-
1033	3205	L. ED I	8.5 13.3.1	6G 64b	-	Aiv	-	-	-	-	-
8.5.1 Incised decoration: combed											
1034	2420	(2)	ED III	8.5.1	6G 36d	-	Aiv	-	-	-	-
1035	2420		ED III	8.5.1	6G 36d	-	Bi	-	-	-	-
1036	2420		ED III	8.5.1	6G 36d	-	Cii	-	-	-	-
1037	2440	(2)	ED IIIB?	8.5.1	6G 36a	-	Ai	-	-	-	-
1038	2440		ED IIIB?	8.5.1	6G 36a	-	Aiv	-	-	-	-

1	2	3	4	5	6	7	8	9	10	11	12
1039	2792	ED IB	8.5.1 8.6.2	6G 64b	-	Gi	-	-	-	-	-
8.5.2 Incised decoration: cross-hatched											
1040	0404	ED IIIB	8.5.2	6G 66	-	Aiii	-	-	-	-	-
1041	0584	ED III	8.5.2	6G 37a	-	Bii	-	-	-	-	-
1042	2420	ED III	8.5.2	6G 36d	-	Mi	-	-	-	-	-
1043	3205	L. ED II	8.5.2	6G 64b	-	Jii	-	-	-	-	-
1044	6000	ED III	8.5.2	6F 05b	-	Aii	-	-	-	-	-
1045	3222	ED II	8.5.2 13.3.3	6G 64b	-	Eii	-	-	-	-	-
8.6 Impressed decoration											
8.6.1 Impressed decoration: horizontal row of triangular nicks											
1046	3222	ED II	8.6.1	6G 64b	-	Ai	-	-	-	-	-
1047	6000	ED III	8.6.1	6F 05b	-	Cii	-	-	-	-	-
1048	3223	ED II	8.6.1 8.9.2	6G 64b	-	Aiv	-	-	-	-	-
8.6.7 Impressed decoration: horizontal row of lozenge shapes											
1049	0357	(2)	ED III	8.6.7	6G 55d	-	Bii	-	-	-	-
1050	2785	ED IB	8.6.7	6G 64b	-	Ji	-	-	-	-	-
8.6.8 Cable-impressed decoration: horizontal											
1051	0208	L. ED III	8.6.8	6G 65d	-	Ci	-	-	-	-	-

1	2	3	4	5	6	7	8	9	10	11	12
8.8 Striated/grooved decoration (Tab-rim jars)											
8.8.1 Horizontal striated/grooved decoration											
1052	2792	ED IB	8.8.1	6G 64b	-	Avii	-	-	-	-	-
1053	3205	L. ED I	8.8.1	6G 64b	-	Avii	-	-	-	-	-
8.9 Reserve-slipped decoration											
8.9.2 Horizontal reserve slip											
1054	0584	ED III	8.9.2	6G 37a	-	Aiii	331	-	-	50/5	-
1055	1805	(5)	ED III	8.9.2	6G 85c	Ci	-	-	-	-	-
1056	1809	ED III	8.9.2	6G 85b	-	Ci	-	-	-	-	-
1057	2420	ED III	8.9.2	6G 36d	-	Bi	-	-	-	-	-
1058	2420	ED III	8.9.2	6G 36d	-	Ci	-	-	-	-	-
1059	2729	(2)	ED II	8.9.2	6G 64b	Ci	-	-	-	-	-
1060	2729	ED II	8.9.2	6G 64b	-	Diii	-	-	-	-	-
1061	3205	L. ED I	8.9.2	6G 64b	-	Jii	-	-	-	-	-
1062	3223	ED II	8.9.2	6G 64b	-	Ei	-	-	-	-	-
1063	3238	L. ED I	8.9.2 13.3.2	6G 64b	-	Avii	-	-	-	-	-
8.10 Leaf-motif (herring-bone pattern)											
1064	0122	ED III	8.10	6G 54c	-	Bii	-	-	-	-	*
8.11 Plain ribs											
8.11.1 Single plain rib on shoulder carination											
1065	0306	(2)	ED III	8.11.1	6G 55a	Aii	-	-	-	-	-



1	2	3	4	5	6	7	8	9	10	11	12	
1066	0584	(2)	ED III	8.11.1	6G 37a	-	Aii	-	-	-	-	
1067	0584	(2)	ED III	8.11.1	6G 37a	-	Bii	-	-	-	-	
1068	1809		ED III	8.11.1	6G 85b	-	Aiii	-	-	-	-	
1069	2420	(2)	ED III	8.11.1	6G 36d	-	Bi	-	-	-	-	
1070	2440	(2)	ED IIIB?	8.11.1	6G 36a	-	Aii	-	-	-	-	
1071	2440	(2)	ED IIIB?	8.11.1	6G 36a	-	Biii	-	-	-	-	
1072	2701		ED II/IIIA	8.11.1	6G 64b	-	Aiv	-	-	-	-	
1073	2729	(2)	ED II	8.11.1	6G 64b	-	Eii	-	-	-	-	
1074	2729		ED IB	8.11.1	6G 64b	-	Eii	-	-	-	-	
1075	6000		ED III	8.11.1	6F 05b	-	Li	-	-	-	-	
1076	2729		ED II	8.11.1 8.5.2	6G 64b	-	Biii	-	-	-	-	
1077	0304	(5)	ED	8.11.1 8.12	6G 55d	-	-	-	-	-	-	
8.11.2 Several plain ribs on shoulder												
1078	0404		ED IIIB	8.11.2	6G 66	-	Aiv Ei	324	404A	-	-	*
1079	0584		ED III	8.11.2	6G 37a	-	Aiv	-	-	-	-	
1080	1809		ED III	8.11.2	6G 85b	-	Aiii	-	-	-	-	
1081	0404		ED IIIB	8.11.2 8.6.1	6G 66	-	Aiv	325	404B	-	-	*
1082	0611	(4)	ED III	8.11.2 8.6.1	6G 74b	-	Aiv	-	-	-	-	

1	2	3	4	5	6	7	8	9	10	11	12
8.12 Decorated ribs: notched/nicked											
8.12.1 Single rib with notched decoration											
1083	2420	ED III	8.12.1	6G 36d	-	Aii	-	-	-	-	-
1084	2440	ED IIIB?	8.12.1	6G 36a	-	Aiv	-	-	-	-	-
1085	2440	ED IIIB?	8.12.1	6G 36a	-	Bii	-	-	-	-	-
1086	2729	(7) ED II	8.12.1	6G 64b	-	Aiv	-	-	-	-	-
1087	2729	(10) ED II	8.12.1	6G 64b	-	Bi	-	-	-	-	-
1088	2729	ED II	8.12.1	6G 64b	-	Eii	-	-	-	-	-
1089	2729	ED II	8.12.1	6G 64b	-	Dii	-	-	-	-	-
1090	2785	ED IB	8.12.1	6G 64b	-	Gii	-	-	-	-	-
1091	2792	ED IB	8.12.1	6G 64b	-	Eii	-	-	-	-	-
1092	3223	ED II	8.12.1	6G 64b	-	Gii	-	-	-	-	-
1093	6000	ED III	8.12.1	6F 05b	-	Ciii	-	-	-	-	-
8.12.2 Several ribs with notched decoration											
1094	0584	ED III	8.12.2	6G 37a	-	Av	-	-	-	-	-
8.12.3 Single ribbed with notched decoration, perforated at intervals											
1095	0055	ED	8.12.3	6G 64	-	Aiv	-	-	-	-	*
8.13 Decorated ribs: cable/piecrust											
8.13.1 Narrow cable rib (fine ware)											
1096	0306	ED III	8.13.1	6G 55a	-	Aii	-	-	-	-	-
1097	0354	ED IIIA/B	8.13.1	6G 55a	-	Ci	-	-	-	-	-

1	2	3	4	5	6	7	8	9	10	11	12
1098	0404		ED IIIB	8.13.1	6G 66	-	Aii	-	-	-	-
1099	0404	(3)	ED IIIB	8.13.1	6G 66	-	Ci	-	-	-	-
1100	0404	(2)	ED IIIB	8.13.1	6G 66	-	Cii	-	-	-	-
1101	0509	(3)	ED III	8.13.1	6G 37c	-	Cii	-	-	-	-
1102	2729	(2)	ED II	8.13.1	6G 64b	-	Ai	-	-	-	-
1103	2729	(5)	ED II	8.13.1	6G 64b	-	Bi	-	-	-	-
1104	2729	(2)	ED II	8.13.1	6G 64b	-	Ciii	-	-	-	-
1105	2785		ED IB	8.13.1	6G 64b	-	Ai	-	-	-	-
8.13.2 Wide cable rib											
1106	0354		ED IIIA/B	8.13.2	6G 55a	-	Aiv	-	-	-	-
1107	0507	(5)	ED III	8.13.2	6G 37b	-	Biii	-	-	-	-
1108	0584		ED III	8.13.2	6G 37a	-	Aii	-	-	-	-
1109	0584		ED III	8.13.2	6G 37a	-	Ni	-	-	-	-
1110	1804		ED III	8.13.2	6G 85c	-	Avi	-	-	-	-
1111	3222	(2)	ED II	8.13.2	6G 64b	-	Bvi	-	-	-	-
1112	3222		ED II	8.13.2 13.3	6G 64b	-	Jii	-	-	-	-
8.15 'Well-type': combed, wavy line decoration											
1113	0306	(94)	Akkad.?	8.15	6G 55a	-	Miii	-	-	-	-
8.16 Decorated coarse ware body sherds (large jars)											
8.16.1 Coarse ware: single plain rib											
1114	0209		ED	8.16.1	6G 65c	-	Qi?	-	-	-	-

1	2	3	4	5	6	7	8	9	10	11	12
1115	2440	ED IIIB?	8.16.1	6G 36a	-	Qi?	-	-	-	-	-
1116	0584	ED III	8.16.1	6G 36a	-	Qi	-	-	-	-	-
1117	0584	ED III	8.16.1 13.3.3	6G 37a	-	Qi	-	-	-	-	-
1118	0584	ED III	8.16.1.1 13.3.2	6G 37a	-	Qi	-	-	-	-	-
8.16.2 Coarse ware: single cable rib											
1119	0357	ED III	8.16.2	6G 55d	-	Qi	-	-	-	-	-
1120	2729	(6) ED II	8.16.2	6G 64b	-	Qi	-	-	-	-	-
1121	2729	ED II	8.16.2	6G 64b	-	Qii	-	-	-	-	-
1122	6000	ED III	8.16.2	6F 05b	-	Qi	-	-	-	-	-
1123	1804	ED III	8.16.2 13.3	6G 85c	-	Qii	-	-	-	-	-
1124	3205	L. ED I	8.16.2 13.3.2	6G 64b	-	Qiii	-	-	-	-	-
1125	2420	ED III	8.16.2 13.3.2	6G 36d	-	Qiii	-	-	-	-	-
8.16.3 Coarse ware: incised decoration											
1126	0584	ED III	8.16.3	6G 37a	-	Qi	-	-	-	-	-
8.17 Burnished											
8.17.1 Grey burnished											
1127	0208	L. ED III	8.17.1	6G 65d	-	Hi	-	-	-	-	-
1128	2701	ED II/IIIA	8.17.1	6G 64b	-	Hi	-	-	-	-	-
8.17.5 Pattern-burnished (cross-hatching)											
1129	3205	L. ED I	8.17.5	6G 64b	-	Ciii	-	-	-	-	-

1	2	3	4	5	6	7	8	9	10	11	12
1130	3215	L. ED I	8.17.5	6G 64b	-	Avii	-	-	-	-	-
8.18 Handles											
8.18.1 Strap handles											
1131	0304	ED	8.18.1	6G 55d	-	Jii	-	-	-	-	-
1132	2729	ED II	8.18.1	6G 64b	-	Jii	-	-	-	-	-
8.18.2 Flap pot 'handles'											
1133	0584	ED III	8.18.2	6G 37a	-	Q?	-	-	-	-	-
1134	0614	ED IIIA	8.18.2	6G 74b	-	-	-	-	-	-	-
1135	1809	ED III	8.18.2	6G 85b	-	Qi	-	-	-	-	-
1136	2420	ED III	8.18.2	6G 36d	-	Q?	-	-	-	-	-
8.20 Carinated shoulder sherd											
1137	1804	ED III	8.20 2.2	6G 85c	-	Avii	-	-	-	-	-
9 <u>Upright-handled jars</u>											
1138	1805 : 6G 85 : 41	ED III	9	6G 85c	-	Ciii	-	-	-	-	*
1139	1809 : 6G 85 : 61 6G 85 : 64	ED III	9	6G 85b	-	Ciii	-	-	-	-	*
1140	6000 : 6F 05 : 17	ED III	9	6F 05b	-	Bi	-	-	-	-	*
1141	1805	ED III	9 8.5.2	6G 85c	-	Bii	-	-	-	-	-
1142	3223 : 6G 64 : 1122	ED II	9? 8.5.2	6G 64b	-	Bi	-	-	-	-	-
1143	2078	ED II/III?	9? 8.5.2 8.12.1	-	-	Bvi Bvi	338 339	-	6/24	-	*

1	2	3	4	5	6	7	8	9	10	11	12
1144	3222	ED II	9? 8.11.1	6G 64b	-	Aiv	-	-	-	-	-
1145	3222	ED II	9? 8.11.1	6G 64b	-	Biv	-	-	-	-	-
1146	3222	ED II	9? 8.11.1	6G 64b	-	Aiv	-	-	-	-	-
1147	0584	ED III	9? 8.12.1	6G 37a	-	Bi	-	-	-	-	-
1148	0584	ED III	9? 8.12.1	6G 37a	-	Bii	-	-	-	-	-
1149	0584	ED III	9? 8.12.1	6G 37a	-	Li	-	-	-	-	-
1150	3223	ED II	9? 8.12.1	6G 64b	-	Ai	-	-	-	-	-
1151	1804	ED III	9? 8.13.2	6G 85c	-	Li	-	-	-	-	-
10	Stemmed dishes										
10.2	Stemmed dishes: incised, geometric decoration										
10.2.1	Stemmed dishes: incised, geometric decoration; ribbed and/or perforated										
1152	1805 : 6G 85 : 39	ED III	10.2.1	6G 85c	-	Li	-	-	-	-	*
1153	1809 : 6G 85 : 71	ED III	10.2.1	6G 85b	-	Cii	-	-	-	-	*
1154	6000 : 6F 05 : 9	ED III	10.2.1	6F 05b	-	Li	-	-	-	-	*
1155	6000 : 6F 05 : 25	ED III	10.7.3	6F 05b	-	Li	-	-	-	-	*
10.6	Stemmed dish: plastic decoration added										
1156	3618 : 6G 75 : 145 Abs 2057	ED IIIA/B	10.6	6G 75a	Postgate 1982, 56	Li	466	-	24/33	-	*

1	2	3	4	5	6	7	8	9	10	11	12
10	Stemmed dish sherds										
1157	0306		ED III	10	6G 55a	-	Aii	-	-	-	-
1158	0306	(6)	ED III	10	6G 55a	-	Bi	-	-	-	-
1159	0306	(2)	ED III	10	6G 55a	-	Ciii	-	-	-	-
1160	0356		ED III	10	6G 55d	-	Bi	-	-	-	-
1161	0404		ED IIIB	10	6G 66	-	Bi	-	-	-	-
1162	0509		ED III	10	6G 37c	-	Bi	-	-	-	-
10.1	Stemmed dishes: plain										
1163	2440		ED IIIB?	10.1	6G 36a	-	Aii	-	-	-	-
1164	2440		ED IIIB?	10.1	6G 36a	-	Bi	-	-	-	-
10.1.2	Stemmed dishes: notched ribs and perforated, fenestrated stem										
1165	0306	(2)	ED III	10.1.2	6G 55a	-	Aiv	-	-	-	-
1166	0306	(3)	ED III	10.1.2	6G 55a	-	Bi	-	-	-	-
10.2	Stemmed dishes: incised, geometric decoration										
10.2.2	Stemmed dish: incised, geometric decoration; ribbed										
1167	2729		ED II	10.2.2	6G 64b	-	Bi	-	-	-	-
10.5	Stemmed dishes: incised decoration; flora, fauna, architecture and/or female attributes										
1168	2440		ED IIIB?	10.5	6G 36a	-	Bii	-	-	-	-
10.7	Stemmed dish rims										
10.7.1	Stemmed dish rims: plain										
1169	0404		ED IIIB	10.7.1	6G 66	-	Aii	-	-	-	-

118

1	2	3	4	5	6	7	8	9	10	11	12
1170	0404	(3)	ED IIIB	10.7.1	6G 66	-	Bi	-	-	-	-
1171	0507		ED III	10.7.1	6G 37b	-	Bi	-	-	-	-
1172	0508		ED IIIA	10.7.1	6G 37c	-	Bi	-	-	-	-
1173	0611		ED III	10.7.1	6G 74b	-	Li	-	-	-	-
1174	2729		ED II	10.7.1	6G 64b	-	Jii	-	-	-	-
10.7.2 Stemmed dishes: notched rib											
1175	1804		ED III	10.7.2	6G 85c	-	Bi	-	-	-	-
1176	1804		ED III	10.7.2	6G 85c	-	Cii	-	-	-	-
1177	6000		ED III	10.7.2	6F 05b	-	Li	-	-	-	-
10.7.3 Stemmed dish rims: notched rib and 'wavy-line' decoration											
1178	0509	(3)	ED III	10.7.3	6G 37c	-	Bi	-	-	-	-
1179	1804		ED III	10.7.3	6G 85c	-	Aiv	-	-	-	-
10.8 Stemmed dish bases											
10.8.1 Stemmed dish bases: plain											
1180	0404	(3)	ED IIIB	10.8.1	6G 66	-	Bi	-	-	-	-
1181	0584		ED III	10.8.1	6G 37a	-	Aiv	-	-	-	-
1182	0584		ED III	10.8.1	6G 37a	-	Bi	-	-	-	-
1183	1805		ED III	10.8.1	6G 85c	-	Bi	-	-	-	-
1184	1809		ED III	10.8.1	6G 85b	-	Ciii	-	-	-	-
1185	1809		ED III	10.8.1	6G 85b	-	Li	-	-	-	-
1186	2440		ED IIIB	10.8.1	6G 36a	-	Bi	-	-	-	-

1	2	3	4	5	6	7	8	9	10	11	12
1187	2729		ED II	10.8.1	6G 64b	-	Avii	-	-	-	-
1188	2729		ED II	10.8.1	6G 64b	-	Biii	-	-	-	-
10.8.4 Stemmed dish bases: incised											
1189	0404	(4)	ED IIIB	10.8.4	6G 66	-	Bi	-	-	-	-
1190	0404	(2)	ED IIIB	10.8.4	6G 66	-	Ciii	-	-	-	-
1191	0584		ED III	10.8.4	6G 37a	-	Aiv	330	584B	-	50/4 *
1192	0584	(2)	ED III	10.8.4	6G 37a	-	Bi	-	-	-	-
1193	1804		ED III	10.8.4	6G 85c	-	Aiv	-	-	-	-
1194	1804	(2)	ED III	10.8.4	6G 85c	-	Ciii	-	-	-	-
10.8.5 Stemmed dish bases: incised and perforated											
1195	1804	(3)	ED III	10.8.5	6G 85c	-	Aiv	-	-	-	-
10.8.6 Stemmed dish base: ribbed											
1196	0584		ED III	10.8.6 8.5.2	6G 37a	-	Bi	-	-	-	-
10.9 Stemmed dish: coarse ware											
1197	0306		ED III	10.9	6G 55a	-	Niii	-	-	-	-
11 <u>Hollow stands</u>											
11.1 Small perforated stands ('wash-stand')											
1198	1805	: 6G 85 : 40	ED III	11.1	6G 85c	-	Bi	-	-	-	*
1199	1809	: 6G 85 : 73	ED III	11.1	6G 85b	-	Ciii	-	-	-	*
1200	0356		ED III	11.1	6G 85b	-	Bi	-	-	-	-
1201	0507		ED III	11.1	6G 37b	-	Bi	-	-	-	-

1	2	3	4	5	6	7	8	9	10	11	12
1202	0509		ED III	11.1	6G 37c	-	Bi	-	-	-	-
1203	0584		ED III	11.1	6G 37a	-	Ciii	-	-	-	-
1204	0611		ED III	11.1	6G 74b	-	Bi	-	-	-	-
1205	0614	(2)	ED IIIA	11.1	6G 74b	-	Bi	-	-	-	-
1206	1809		ED III	11.1	6G 85b	-	Ciii	-	-	-	-
1207	2729		ED II	11.1	6G 64b	-	Aiv	-	-	-	-
1208	2729	(3)	ED II	11.1	6G 64b	-	Biii	-	-	-	-
1209	2729	(2)	ED II	11.1	6G 64b	-	Ni	-	-	-	-
1210	3205		L. ED I	11.1	6G 64b	-	Jii	-	-	-	-
1211	6000		ED III	11.1	6F 05b	-	Aiv	-	-	-	-
11.2	Large hollow stands: plain										
1212	0356		ED III	11.2	6G 55d	-	Niii	-	-	-	-
1213	0507		ED III	11.2	6G 37b	-	Ciii	-	-	-	-
1214	0509		ED III	11.2	6G 37c	-	Bii	-	-	-	-
11.3	Hollow stands: ribbed										
1215	1809		ED III	11.3	6G 85b	-	Bi	-	-	-	-
1216	2729		ED II	11.3	6G 64b	-	Ni	-	-	-	-
1217	2792		ED IB	11.3	6G 64b	-	Jii	-	-	-	-
1218	3223		ED II	11.3 11.10	6G 64b	-	Bii	-	-	-	-
1219	3238		L. ED I	11.3 11.10	6G 64b	-	Aiv	-	-	-	-

1	2	3	4	5	6	7	8	9	10	11	12
11.4 Hollow stands: ribbed and fenestrated											
1220	2701		ED II/IIIA	11.4	6G 64b	-	Bi	-	-	-	-
1221	2729	(2)	ED II	11.4	6G 64b	-	Aiv	-	-	-	-
1222	2729		ED II	11.4	6G 64b	-	Biii	-	-	-	-
1223	2729		ED II	11.4	6G 64b	-	Ciii	-	-	-	-
1224	2729		ED II	11.4	6G 64b	-	Niii	-	-	-	-
1225	3203		L. ED I	11.4	6G 64b	-	Ni	-	-	-	-
1226	3222		ED II	11.4	6G 64b	-	Ciii	-	-	-	-
11.5 Hollow stands: ribbed and incised											
1227	0584		ED III	11.5	6G 37b	-	Aiv	-	-	-	-
1228	2729	(2)	ED II	11.5	6G 64b	-	Aiv	-	-	-	-
1229	2729		ED II	11.5	6G 64b	-	Biii	-	-	-	-
1230	2729		ED II	11.5	6G 64b	-	Ciii	-	-	-	-
1231	2729		ED II	11.5	6G 64b	-	Li	-	-	-	-
1232	2792		ED IB	11.5	6G 64b	-	Jii	-	-	-	-
11.6 Hollow stands: ribbed, incised and fenestrated											
1233	2701		ED II/IIIA	11.6	6G 64b	-	Aiii	-	-	-	-
1234	2729		ED II	11.6	6G 64b	-	Bi	-	-	-	-
11.7 Hollow stand: ribbed, incised, fenestrated and perforated											
1235	3205		L. ED I	11.7	6G 64b	-	Cii	-	-	-	-

1	2	3	4	5	6	7	8	9	10	11	12
11.8	Hollow stands: cut ware										
1236	2792	ED IB	11.8	6G 64b	-	Aiv	-	-	-	-	*
1237	3205	L. ED I	11.8	6G 64b	-	Aiv	-	-	-	-	*
11.10	Hollow stand with internal, applied, horizontal ribs										
1238	2729	ED II	11.10	6G 64b	-	Ciii	-	-	-	-	-
12	<u>Miniatures</u>										
12.1	Miniatures: bowl/goblet										
1239	0208	L. ED III	12.1	6G 65d	-	-	-	-	-	-	-
12.2	Miniatures: cup										
1240	2792	ED IB	12.2	6G 64b	-	-	-	-	-	-	-
12.3	Miniatures: 'bag-pot' or 'thumb-pot'										
1241	0208	L. ED III	12.3	6G 65d	-	-	-	-	-	-	-
1242	0611	(2)	ED III	12.3	6G 74b	-	-	-	-	-	-
12	Miniatures: sherds										
1243	1804	ED III	12 2.4.2.1	6G 85c	-	Aii	-	-	-	-	-
1244	2235	ED IIIA/B	12 8.12.1	6G 62a	-	Bii	-	-	-	-	-
13	<u>Painted ware (body sherds)</u>										
13.1	Painted ware: monochrome										
13.1.1	Monochrome: red-scarlet										
1245	0085	ED IIIB?	13.1.1	6G 64b	-	Di	323	-	15/4	-	-
1246	0584	ED III	13.1.1	6G 37a	-	Avii	-	-	-	-	-

1	2	3	4	5	6	7	8	9	10	11	12
1247	0584	ED III	13.1.1	6G 37a	-	Ci	-	-	-	-	-
1248	2701	ED II/IIIA	13.1.1	6G 64b	-	Other :1	354	-	15/2	-	-
13.1.5 Monochrome: red-orange											
1249	1809	ED III	13.1.5	6G 85b	-	Eii	336	-	-	-	-
13.2 Painted ware: polychrome											
13.2.1 Polychrome: red on white slip											
1250	1029	ED IIIB	13.2.1 2.3	5I 10b	-	Eii	335	1029A	-	50/2	-
1251	6012 : 6F 05 : 181	ED III	13.2.1? 2.3	6F 05	-	Other :2	560	6F 05 :181	14/34	-	-
13.3 Bitumen-coated wares											
13.3.1 Bitumen-coated outside											
1252	1809	ED III	13.3.1	6G 85b	-	Mii	-	-	-	-	-
1253	2420 (2)	ED III	13.3.1	6G 36d	-	Ci	-	-	-	-	-
1254	2785	ED IB	13.3.1	6G 64b	-	Aiii	-	-	-	-	-
13.3.2 Bitumen-coated inside											
1255	1804	ED III	13.3.2	6G 85c	-	Qi	-	-	-	-	-
14 Bases											
14.1 Flat bases											
14.1.1 Flat bases: string-cut. (Conical bowls)											
1256	0054 (5)	ED IIIA	14.1.1 1.1	6G 64	-	-	-	-	-	-	-
1257	0055 (26)	ED	14.1.1 1.1	6G 64	-	-	-	-	-	-	-

1	2	3	4	5	6	7	8	9	10	11	12
1258	0208	(15)	L. ED III	14.1.1 1.1	6G 65d	-	-	-	-	-	-
1259	0304	(1)	ED	14.1.1 1.1	6G 55d	-	-	-	-	-	-
1260	0306	(43)	ED III	14.1.1 1.1	6G 55a	-	-	-	-	-	-
1261	0354	(8)	ED IIIA/B	14.1.1 1.1	6G 55a	-	-	-	-	-	-
1262	0356	(2)	ED III	14.1.1 1.1	6G 55d	-	-	-	-	-	-
1263	0357	(71)	ED III	14.1.1 1.1	6G 55d	-	-	-	-	-	-
1264	0403	(1)	ED III	14.1.1 1.1	6G 66	-	-	-	-	-	-
1265	0507	(18)	ED III	14.1.1 1.1	6G 37b	-	-	-	-	-	-
1266	0508	(7)	ED IIIA?	14.1.1 1.1	6G 37c	-	-	-	-	-	-
1267	0584		ED III	14.1.1 1.1	6G 37a	-	Aii	328	584A	-	*
1268	0584	(9)	ED III	14.1.1 1.1	6G 37a	-	Aii	-	-	-	-
1269	0584	(8)	ED III	14.1.1 1.1	6G 37a	-	Aiii	-	-	-	-
1270	0584	(15)	ED III	14.1.1 1.1	6G 37a	-	Aiv	-	-	-	-
1271	0584	(6)	ED III	14.1.1 1.1	6G 37a	-	Bii	-	-	-	-
1272	0584	(5)	ED III	14.1.1 1.1	6G 37a	-	Cii	-	-	-	-
1273	0611	(19)	ED III	14.1.1 1.1	6G 74b	-	-	-	-	-	-

1	2	3	4	5	6	7	8	9	10	11	12
1274	0614	(9)	ED IIIA	14.1.1 1.1	6G 74b	-	-	-	-	-	-
1275	1804	()	ED III	14.1.1 1.1	6G 85c	-	Aii	-	-	-	-
1276	1804	(5)	ED III	14.1.1 1.1	6G 85c	-	Aiv	-	-	-	-
1277	1804	(2)	ED III	14.1.1 1.1	6G 85c	-	Bii	-	-	-	-
1278	1804	(2)	ED III	14.1.1 1.1	6G 85c	-	Ciii	-	-	-	-
1279	1805	(3)	ED III	14.1.1 1.1	6G 85c	-	Aiv	-	-	-	-
1280	1805		ED III	14.1.1 1.1	6G 85c	-	Bi	-	-	-	-
1281	1805	(4)	ED III	14.1.1 1.1	6G 85c	-	Bii	-	-	-	-
1282	1805	(3)	ED III	14.1.1 1.1	6G 85c	-	Cii	-	-	-	-
1283	1809	(3)	ED III	14.1.1 1.1	6G 85b	-	Aiii	-	-	-	-
1284	1809	(3)	ED III	14.1.1 1.1	6G 85b	-	Aiv	-	-	-	-
1285	1809	(4)	ED III	14.1.1 1.1	6G 85b	-	Bii	-	-	-	-
1286	1809	(2)	ED III	14.1.1 1.1	6G 85b	-	Ciii	-	-	-	-
1287	2235	(8)	ED IIIA/B	14.1.1 1.1	6G 62a	-	-	-	-	-	-
1288	2420		ED III	14.1.1 1.1	6G 36d	-	Aiii	-	-	-	-
1289	2420	(10)	ED III	14.1.1 1.1	6G 36d	-	-	-	-	-	-

1	2	3	4	5	6	7	8	9	10	11	12
1290	2440	(148)	ED IIIB?	14.1.1 1.1	6G 36a	-	-	-	-	-	-
1291	2701		ED II/IIIA	14.1.1 1.1	6G 64b	-	Aii	-	-	-	-
1292	2701	(16)	ED II/IIIA	14.1.1 1.1	6G 64b	-	-	-	-	-	-
1293	2729	(49)	ED II	14.1.1 1.1	6G 64b	-	Aiv	-	-	-	-
1294	2729	(26)	ED II	14.1.1 1.1	6G 64b	-	Av	-	-	-	-
1295	2729	(11)	ED II	14.1.1 1.1	6G 64b	-	Avi	-	-	-	-
1296	2729	(4)	ED II	14.1.1 1.1	6G 64b	-	Avii	-	-	-	-
1297	2729	(71)	ED II	14.1.1 1.1	6G 64b	-	Bii	-	-	-	-
1298	2729	(63)	ED II	14.1.1 1.1	6G 64b	-	Biii	-	-	-	-
1299	2729	(20)	ED II	14.1.1 1.1	6G 64b	-	Cii	-	-	-	-
1300	2785		ED IB	14.1.1 1.1	6G 64b	-	Cii	-	-	-	-
1301	2785	(12)	ED IB	14.1.1 1.1	6G 64b	-	-	-	-	-	-
1302	2792	(10)	ED IB	14.1.1 1.1	6G 64b	-	-	-	-	-	-
1303	3203		L. ED I	14.1.1 1.1	6G 64b	-	-	-	-	-	-
1304	3205	(4)	L. ED I	14.1.1 1.1	6G 64b	-	-	-	-	-	-
1305	3215		L. ED I	14.1.1 1.1	6G 64b	-	Niii	-	-	-	-

1	2	3	4	5	6	7	8	9	10	11	12
1306	3215		L. ED I	14.1.1 1.1	6G 64b	-	Bix	-	-	-	-
1307	3222	(2)	ED II	14.1.1 1.1	6G 64b	-	Bii	-	-	-	-
1308	3222	(5)	ED II	14.1.1 1.1	6G 64b	-	Cii	-	-	-	-
1309	3222	(5)	ED II	14.1.1 1.1	6G 64b	-	Ni	-	-	-	-
1310	3223	(7)	ED II	14.1.1 1.1	6G 64b	-	Ciii	-	-	-	-
1311	3223	(3)	ED II	14.1.1 1.1	6G 64b	-	Niii	-	-	-	-
1312	3237	(3)	L. ED I	14.1.1 1.1	6G 64b	-	Niii	-	-	-	-
1313	6000	(7)	ED III	14.1.1 1.1	6G 64b	-	Aiv	-	-	-	-
1314	6000	(3)	ED III	14.1.1 1.1	6G 64b	-	Cii	-	-	-	-
1315	6000	(7)	ED III	14.1.1 1.1	6G 64b	-	Cii	-	-	-	-
14.1.1 Flat bases: string-cut (Footed goblets)											
1316	1804	(1)	ED III	14.1.1 1.3.1	6G 85c	-	Aiv	-	-	-	-
1317	2440	(3)	ED III B?	14.1.1 1.3.1	6G 36a	-	Cii	-	-	-	-
1318	6000	(1)	ED III	14.1.1 1.3.1	6G 64b	-	Bii	-	-	-	-
14.1.1 Flat bases: string-cut (Solid-footed goblets)											
1319	0054	(2)	ED IIIA	14.1.1 1.3.1	6G 64	-	-	-	-	-	-

1	2	3	4	5	6	7	8	9	10	11	12
1320	0055	(2)	ED	14.1.1 1.3.1	6G 64	-	-	-	-	-	-
1321	0306	(4)	ED III	14.1.1 1.3.2	6G 55a	-	-	-	-	-	-
1322	0356		ED III	14.1.1 1.3.2	6G 55d	-	-	-	-	-	-
1323	0404		ED IIIB	14.1.1 1.3.2	6G 66	-	Cii	-	-	-	-
1324	0584		ED III	14.1.1 1.3.2	6G 37a	-	Cii	-	-	-	-
1325	0611		ED III	14.1.1 1.3.2	6G 74b	-	-	-	-	-	-
1326	0614		ED IIIA	14.1.1 1.3.2	6G 74b	-	-	-	-	-	-
1327	0616	(2)	ED III	14.1.1 1.3.2	6G 74b	-	-	-	-	-	-
1328	1805		ED III	14.1.1 1.3.2	6G 85c	-	Cii	-	-	-	-
1329	2235	(2)	ED IIIA/B	14.1.1 1.3.2	6G 62a	-	-	-	-	-	-
1330	2701		ED II/IIIA	14.1.1 1.3.2	6G 64b	-	-	-	-	-	-
1331	2729		ED II	14.1.1 1.3.2	6G 64b	-	Cii	-	-	-	-
1332	2785		ED Ib	14.1.1 1.3.2	6G 64b	-	Aiv	-	-	-	-
1333	2792		ED Ib	14.1.1 1.3.2	6G 64b	-	Aiii	-	-	-	-
1334	3205		L. ED I	14.1.1 1.3.2	6G 64b	-	Biii	-	-	-	-
1335	3205	(2)	L. ED I	14.1.1 1.3.2	6G 64b	-	Cii	-	-	-	-

1	2	3	4	5	6	7	8	9	10	11	12
1336	3215	(2)	L. ED I	14.1.1 1.3.2	6G 64b	-	Avii	-	-	-	-
1337	3223		ED II	14.1.1 1.3.2	6G 64b	-	-	-	-	-	-
1338	3229		L. ED I	14.1.1 1.3.2	6G 64b	-	Cii	-	-	-	-
14.1.1 Flat bases: string-cut (other)											
1339	0304		ED	14.1.1	6G 55d	-	-	-	-	-	-
1340	0306		ED III	14.1.1	6G 55a	-	-	-	-	-	-
1341	0354		ED IIIA/B	14.1.1	6G 55a	-	Aiv	-	-	-	-
1342	1809	: 6G 85 : 5	ED III	14.1.1	6G 85b	-	Aiv	-	-	-	-
1343	2729		ED II	14.1.1	6G 64b	-	Bix	-	-	-	-
1344	0306		ED III	14.1.1 2.3	6G 55a	-	-	-	-	-	-
14.1.2 Flat or slightly convex bases											
1345	0584	(3)	ED III	14.1.2	6G 37a	-	Aiv	-	-	-	-
1346	0584		ED III	14.1.2	6G 85c	-	Bii	-	-	-	-
1347	0584		ED III	14.1.2	6G 85c	-	Biv	-	-	-	-
1348	0584	(2)	ED III	14.1.2	6G 85c	-	Ci	-	-	-	-
1349	1804	(2)	ED III	14.1.2	6G 85c	-	Aiii	-	-	-	-
1350	1804		ED III	14.1.2	6G 85c	-	Bi	-	-	-	-
1351	1804	(2)	ED III	14.1.2	6G 85c	-	Bii	-	-	-	-
1352	1804		ED III	14.1.2	6G 85c	-	Li	-	-	-	-
1353	1805		ED III	14.1.2	6G 85c	-	Ci	-	-	-	-

1	2	3	4	5	6	7	8	9	10	11	12
1354	1809	(2)	ED III	14.1.2	6G 85b	-	Aiv	-	-	-	-
1355	1809		ED III	14.1.2	6G 85b	-	Bii	-	-	-	-
1356	1809	(2)	ED III	14.1.2	6G 85b	-	Ci	-	-	-	-
1357	2440		ED IIIIB?	14.1.2	6G 36a	-	Aiv	343	2440E	-	*
1358	2440		ED IIIIB?	14.1.2	6G 36a	-	Liii	342	-	-	-
1359	2440	(3)	ED IIIIB?	14.1.2	6G 36a	-	Mi	-	-	-	-
1360	2701		ED II/IIIA	14.1.2	6G 64b	-	Aiv	-	-	-	-
1361	2701		ED II/IIIA	14.1.2	6G 64b	-	Ci	-	-	-	-
1362	2729		ED II	14.1.2	6G 64b	-	Aiv	-	-	-	-
1363	2729	(2)	ED II	14.1.2	6G 64b	-	Bii	-	-	-	-
1364	2729	(7)	ED II	14.1.2	6G 64b	-	Ci	-	-	-	-
1365	2729	(2)	ED II	14.1.2	6G 64b	-	Cii	-	-	-	-
1366	2785		ED IB	14.1.2	6G 64b	-	Aiv	-	-	-	-
1367	2785	(4)	ED IB	14.1.2	6G 64b	-	Ci	-	-	-	-
1368	2785	(2)	ED IB	14.1.2	6G 64b	-	Eii	-	-	-	-
1369	2792	(2)	ED IB	14.1.2	6G 64b	-	Ci	-	-	-	-
1370	3203		L. ED I	14.1.2	6G 64b	-	Ci	-	-	-	-
1371	3205		L. ED I	14.1.2	6G 64b	-	Ci	-	-	-	-
1372	3223	(3)	ED II	14.1.2	6G 64b	-	-	-	-	-	-
1373	6000		ED III	14.1.2	6F 05b	-	Aiv	-	-	-	-
1374	6000		ED III	14.1.2	6F 05b	-	-	-	-	-	-

1	2	3	4	5	6	7	8	9	10	11	12
1375	2729	ED II	14.1.2 13.3.1	6G 64b	-	Av	-	-	-	-	-
1376	3223	ED II	14.1.2 13.3.2	6G 64b	-	Aiii	-	-	-	-	-
14.1.3 Flat or slightly convex bases: perforated											
1377	0208	L. ED III	14.1.3	6G 65d	-	-	-	-	-	-	-
1378	0306	ED III	14.1.3	6G 55a	-	-	-	-	-	-	-
1379	2440	ED IIIB?	14.1.3	6G 36a	-	Aiv	-	-	-	-	-
14.1.4 Convex base											
1380	2440	ED IIIB?	14.1.4	6G 36a	-	Aiii	344	-	-	-	*
14.1.5 Flat base: coarse ware											
1381	2440	ED IIIB?	14.1.5	6G 36a	-	Qi	-	-	-	-	-
14.2 Round/ovoid bases											
1382	6000 : 6F 05 : 10	ED III	14.2	6F 05b	-	Bi	-	-	-	-	*
14.2.1 Round bases: coarse ware											
1383	0354	ED IIIA/B	14.2.1	6G 55a	-	P?	-	-	-	-	-
1384	6000	ED III	14.2.1 8.17.2	6F 05b	-	Cii	-	-	-	-	-
14.3 Ring bases											
14.3.1 Ring bases: pinched											
1385	0584	ED III	14.3.1	6G 37a	-	Aiii	-	-	-	-	-
1386	2235	ED IIIA/B	14.3.1	6G 62a	-	Aiii	-	-	-	-	-
1387	2729	ED II	14.3.1	6G 64b	-	Aiii	-	-	-	-	-

1	2	3	4	5	6	7	8	9	10	11	12
1388	2729	ED II	14.3.1	6G 64b	-	Ci	-	-	-	-	-
1389	3205	L. ED I	14.3.1	6G 64b	-	Aiii	-	-	-	-	-
1390	0584	ED III	14.3.1 13.3.1	6G 37a	-	Li	-	-	-	-	-
14.3.2 Ring bases: low											
1391	0054	ED IIIA	14.3.2	6G 64	-	-	-	-	-	-	-
1392	0055	(3) ED	14.3.2	6G 64	-	-	-	-	-	-	-
1393	0208	L. ED III	14.3.2	6G 65d	-	-	-	-	-	-	-
1394	0209	ED	14.3.2	6G 65c	-	-	-	-	-	-	-
1395	0304	(10) ED	14.3.2	6G 55d	-	-	-	-	-	-	-
1396	0306	(25) ED III	14.3.2	6G 55a	-	-	-	-	-	-	-
1397	0354	(3) ED IIIA/B	14.3.2	6G 55a	-	-	-	-	-	-	-
1398	0355	ED III	14.3.2	6G 55d	-	-	-	-	-	-	-
1399	0357	ED III	14.3.2	6G 55d	-	Bi	-	-	-	-	-
1400	0404	(12) ED IIIB	14.3.2	6G 66	-	-	-	-	-	-	-
1401	0507	(6) ED III	14.3.2	6G 37b	-	-	-	-	-	-	-
1402	0584	ED III	14.3.2	6G 37a	-	Bii	-	-	-	-	-
1403	0584	ED III	14.3.2	6G 37a	-	Ci	-	-	-	-	-
1404	0611	(8) ED III	14.3.2	6G 74b	-	-	-	-	-	-	-
1405	0614	ED IIIA	14.3.2	6G 74b	-	Aiv	-	-	-	-	-
1406	1804	(8) ED III	14.3.2	6G 85c	-	Aiii	-	-	-	-	-
1407	1804	ED III	14.3.2	6G 85c	-	Ciii	-	-	-	-	-

1	2	3	4	5	6	7	8	9	10	11	12
1408	1809	ED III	14.3.2	6G 85b	-	Li	-	-	-	-	-
1409	2235	ED IIIA/B	14.3.2	6G 62a	-	Aiv	-	-	-	-	-
1410	2440	ED IIIB?	14.3.2	6G 36a	-	Li Aviii	348 -	2440A1 2440A2	-	-	*
1411	2440	ED IIIB?	14.3.2	6G 36a	-	Aiii	346 -	2440B1 2440B2	-	-	*
1412	2440	(5)	ED IIIB?	14.3.2	6G 36a	-	Av	-	-	-	-
1413	2440	(2)	ED IIIB?	14.3.2	6G 36a	-	Biii	-	-	-	-
1414	2729	(6)	ED II	14.3.2	6G 64b	-	Aviii	-	-	-	-
1415	2729	(4)	ED II	14.3.2	6G 64b	-	Bii	-	-	-	-
1416	2729		ED II	14.3.2 13.3.1	6G 64b	-	Eii	-	-	-	-
1417	3222		ED II	14.3.2	6G 64b	-	Jii	-	-	-	-
14.3.3 Ring bases: high											
1418	0584	ED III	14.3.3	6G 37a	-	Bii	-	-	-	-	-
1419	1805	ED III	14.3.3	6G 85c	-	Aiv	-	-	-	-	-
1420	1809	: 6G 85 : 31	ED III	14.3.3	6G 85b	-	Ciii	-	-	-	-
1421	1809	(2)	ED III	14.3.3	6G 85b	-	Bii	-	-	-	-
1422	2701		ED II/IIIA	14.3.3	6G 64b	-	Li	-	-	-	-
14.3.4 Ring bases: added											
1423	0306	ED III	14.3.4	6G 55a	-	-	-	-	-	-	-
1424	0507	ED III	14.3.4	6G 37a	-	-	-	-	-	-	-
1425	0509	ED III	14.3.4	6G 37a	-	-	-	-	-	-	-

1	2	3	4	5	6	7	8	9	10	11	12
1426	0584		ED III	14.3.4	6G 37a	-	Aii	-	-	-	-
1427	0584	(2)	ED III	14.3.4	6G 37a	-	Aiv	-	-	-	-
1428	0584	(7)	ED III	14.3.4	6G 37a	-	Aviii	-	-	-	-
1429	0584	(4)	ED III	14.3.4	6G 37a	-	Bii	-	-	-	-
1430	0584	(3)	ED III	14.3.4	6G 37a	-	Biii	-	-	-	-
1431	1804		ED III	14.3.4	6G 85c	-	Bviii	-	-	-	-
1432	1809		ED III	14.3.4	6G 85b	-	Bviii	-	-	-	-
1433	2420	(3)	ED III	14.3.4	6G 36d	-	Bviii	-	-	-	-
1434	2420		ED III	14.3.4	6G 36d	-	Ci	-	-	-	-
1435	2440	(4)	ED IIIB?	14.3.4	6G 36a	-	Aviii	-	-	-	-
1436	2440	(4)	ED IIIB?	14.3.4	6G 36a	-	Bii	-	-	-	-
1437	2440	(9)	ED IIIB?	14.3.4	6G 36a	-	Bviii	-	-	-	-
1438	2440		ED IIIB?	14.3.4	6G 36a	-	Pi	-	-	-	-
1439	2440		ED IIIB?	14.3.4	6G 36a	-	Li	-	-	-	-
1440	2729		ED II	14.3.4	6G 64b	-	Aiv	-	-	-	-
1441	2729		ED II	14.3.4	6G 64b	-	Aviii	-	-	-	-
1442	2729		ED II	14.3.4	6G 64b	-	Biii	-	-	-	-
1443	2729		ED II	14.3.4	6G 64b	-	Bviii	-	-	-	-
1444	2729		ED II	14.3.4	6G 64b	-	Ni	-	-	-	-
1445	3223		ED II	14.3.4	6G 64b	-	Aviii	-	-	-	-
1446	6000	(2)	ED III	14.3.4	6F 05b	-	Aiv	-	-	-	-

1	2	3	4	5	6	7	8	9	10	11	12
1447	2729	(2)	ED II	14.3.4	6G 64b	-	Pi	-	-	-	-
1448	0584		ED III	14.3.4 13.3.2	6G 37a	-	Aiv	-	-	-	-
1449	2792		ED IB	14.3.4.1	6G 64b	-	Aviii	-	-	-	-
14.3.5 Ring bases: coarse ware											
1450	0306		ED III	14.3.5	6G 55a	-	-	-	-	-	-
1451	1805		ED III	14.3.5	6G 85c	-	Q	-	-	-	-
1452	1809		ED III	14.3.5	6G 85b	-	Q	-	-	-	-
1453	2440		ED IIIB?	14.3.5	6G 36a	-	Bviii	-	-	-	-
ABU SALABIKH: MAIN MOUND, AREA A											
1	<u>Bowls</u>										
1.1	Conical bowls										
1454	4473		ED II	1.1 rim > 15cm	4J 97	-	Bix	417	-	-	-
1455	4473		ED II	1.1 rim < 15cm	4J 97	-	Cii	397	-	-	-
1456	4473		ED II	1.1 rim < 15cm	4J 97	-	Cii	398	-	-	-
1.14	Bowl rim sherds										
1.14.3	Bowl sherds: medium; plain rim										
1457	4473		ED II	1.14.3.2	4J 97	-	Cii	377	-	-	*
1.14.6	Bowl sherds: medium; bevelled/everted rims										
1458	4473		ED II	1.14.6.3	4J 97	-	Ei	373	-	-	*
1459	4473		ED II	1.14.6.9	4J 97	-	Bv	413	-	23/30	*

1	2	3	4	5	6	7	8	9	10	11	12
1.15	Large bowl sherds: coarse ware rims										
1.15.9	Bowl sherd: coarse ware, shallow dish										
1460	4473	ED II	1.15.9	4J 97	-	Diii	424	-	23/35	-	-
2	<u>Jars</u>										
2.3	Large jar (sherd)										
1461	4473	ED II	2.3	4J 97	-	Giii	426	-	24/3	-	*
2.4	Jar rim sherds										
2.4.1	Jar rim sherds: hole-mouthed										
1462	4473	ED II	2.4.1.3	4J 97	-	Ei	405	-	22/30	-	*
1463	4473	ED II	2.4.1.5	4J 97	-	Mii	427	-	24/5	-	*
2.4.2	Jar rim sherds: short neck										
1464	4473	ED II	2.4.2.1	4J 97	-	Eii	393	-	-	-	*
1465	4473	ED II	2.4.2.7	4J 97	-	Ciii	401	-	-	-	*
1466	4473	ED II	2.4.2.7	4J 97	-	Ei Ai	375 379	-	-	-	*
2.4.3	Jar rim sherds: long neck										
1467	4473	ED II	2.4.3.1	4J 97	-	Biii	420	-	23/27	-	*
1468	4473	ED II	2.4.3.1	4J 97	-	Ei	385	-	-	-	*
1469	4473	ED II	2.4.3.2	4J 97	-	Ei	386	-	-	-	*

1	2	3	4	5	6	7	8	9	10	11	12
2.4.4 Jar sherds: rolled rims											
1470	4473	ED II	2.4.4.2	4J 97	-	Aviii	414	-	23/11	-	*
2.4.7 Jar sherds: collar/band rim; dished/grooved											
1471	4473	ED II	2.4.7.1	4J 97	-	Bi	419	-	-	-	*
2.4.8 Jar sherds: flat rim											
1472	4473	ED II	2.4.8.1	4J 97	-	Bi	-	-	-	-	-
4 <u>'Drinking bottles'</u>											
4.2 'Drinking' bottles: pilgrim flask											
1473	4473	ED III?	Pilgrim flask	4J 97	Delougaz 1952, pl.167; B816.521a	Ei	376	-	22/21	-	*
5 <u>Spouted jars</u>											
1474	4473	ED II	5	4J 97	-	Avi	400	-	22/27	-	-
5.7 Spouted jar sherds: spouts											
1475	4473	ED II	5.7	4J 97	-	Avi	399	-	22/9	-	*
1476	4473	ED II	5.7	4J 97	-	Ai	409	-	-	-	*
1477	4473	ED II	5.7 8.20	4J 97	-	Ei	387	-	-	-	*
5.7.1 Short spouts											
1478	4473	ED II	5.7.1	4J 97	-	Eii?	428	-	23/6	-	*
1479	4473	ED II	5.7.1	4J 97	-	Ei	388	-	22/18	-	*
1480	4473	ED II	5.7.1	4J 97	-	Ai	407	-	22/38	-	*

1	2	3	4	5	6	7	8	9	10	11	12	
5.7.2 Long spout												
1481	4473	ED II	5.7.1	4J 97	-	Ei	389	-	-	-	*	
5.7.3 Conical spout												
1482	4473	ED II	5.7.3	4J 97	-	Eii	391	-	-	-	*	
1483	4473	ED II	5.7.3 13.3.1	4J 97	-	Ei	372	-	-	-	*	
8 <u>Body sherds (jars)</u>												
8.11 Plain ribs												
8.11.1 Single plain rib on shoulder carination												
1484	4473	ED II	8.11.1	4J 97	-	Ciii	-	-	-	-	*	
1485	4473	(2)	ED II	8.11.1	4J 97	-	Ei Ei	383 384	-	22/13	-	*
1486	4473	ED II	8.11.1	4J 97	-	Ei	374	-	22/7	-	*	
1487	4473	ED II	8.11.1	4J 97	-	Ci	396	-	-	-	*	
8.12 Decorated ribs: notched/nicked												
8.12.1 Single rib with notched/nicked decoration												
1488	4473	ED II	8.12.1	4J 97	-	Ciii	402	-	-	-	*	
1489	4473	ED II	8.12.1	4J 97	-	Aiv	403	-	-	-	*	
8.16 Decorated coarse ware (large jars)												
8.16.2 Coarse ware: single cable rib												
1490	4473	ED II	8.16.2	4J 97	-	Dij	415	-	-	-	*	

1	2	3	4	5	6	7	8	9	10	11	12
9	<u>Upright-handled jars</u>										
1491	4473	ED II	9 8.5.2 8.17.2	4J 97	-	Biii	418	-	-	-	*
1492	4473	ED II	9 8.5.3	4J 97	-	Ai	408	-	23/3	-	*
10	Stemmed dishes										
10.7	Stemmed dish rims										
10.7.1	Stemmed dish rims: plain										
1493	4473	ED II	10.7.1	4J 97	-	Biii	421	-	-	-	*
1494	4473	ED II	10.7.1	4J 97	-	Biii	422	-	-	-	*
1495	4473	ED II	10.7.1	4J 97	-	Ciii	423	-	-	-	*
10.7.3	Stemmed dish rims: notched rib and 'wavy-line' decoration										
1496	4473	ED II	10.7.3	4J 97	-	Cii	425	-	23/36	-	*
10.8	Stemmed dish bases										
10.8.2	Stemmed dish bases: ribbed										
1497	4473	ED II	10.8.2	4J 97	-	Biii	416	-	23/16 23/18	-	*
1498	4473	ED II	10.8.2	4J 97	-	Ei	370	-	-	-	*
1499	4473	ED II	10.8.2	4J 97	-	Av	412	-	-	-	-
10.8.3	Stemmed dish bases: perforated										
1500	4473	ED II	10.8.3	4J 97	-	Ai	406	-	-	-	*

1	2	3	4	5	6	7	8	9	10	11	12
11	<u>Hollow stands</u>										
11.1	Small perforated stand ('wash-stand')										
1501	4473	ED II	11.1	4J 97	-	Ei	390	-	-	-	-
11.2	Large hollow stand: plain										
1502	4473	ED II	11.2	4J 97	-	Ei	382	-	-	-	*
11.3	Hollow stand: ribbed										
1503	4473	ED II	11.3	4J 97	-	Eii	394	-	22/25	-	*
14	<u>Bases</u>										
14.1	Flat bases										
14.1.1	Flat bases: string-cut (Conical bowls)										
1504	4473	ED II	14.1.1 1.1	4J 97	-	Aiv	369	-	22/2	-	*
1505	4473	ED II	14.1.1 1.1	4J 97	-	Ei	371	-	-	-	*
1506	4473	ED II	14.1.1 1.1	4J 97	-	Ei	381	-	-	-	*
1507	4473	ED II	14.1.1 1.1	4J 97	-	Cii?	395	-	-	-	*
1508	4473	ED II	14.1.1 1.1	4J 97	-	Avi	404	-	-	-	*
1509	4473	ED II	14.1.1 1.1	4J 97	-	Aiv	378	-	22/31	-	*
14.1.1	Flat bases: string-cut (Solid-footed goblets)										
1510	4473	ED II	14.1.1 1.3.2	4J 97	-	Av	410	-	-	-	*

1	2	3	4	5	6	7	8	9	10	11	12
1511	4473	ED II	14.1.1 1.3.2	4J 97	-	Av	411	-	-	-	-
14.3 Ring bases											
14.3.1 Ring base: pinched											
1512	4473	ED II	14.3.1	4J 97	-	Ai	380	-	22/35	-	*
14.3.4 Ring base: added											
1513	4473	ED II	14.3.4	4J 97	-	Ciii	392	-	22/21	-	*
ABU SALABIKH: NORTH-EAST MOUND											
1 <u>Bowls</u>											
1.3 Goblets											
1.3.2 Solid-footed goblet											
1514	4039	ED I/II	1.3.2	Grave	-	Bii	-	-	-	-	-
1.14 Bowl rim sherds											
1.14.3 Bowl sherds: medium; plain rim											
1515	4054	ED I/II	1.14.3.5	Grave	-	Ei	-	-	-	-	-
1.14.7 Bowl sherds: large rims											
1516	4032	ED I/II	1.14.7.1	Grave	-	Ei	362	-	-	-	*
Bevel-rim bowl (BRB)											
1517	4047	ED I/II	BRB	Grave	-	Ni	-	-	-	-	-
1518	4050	ED I/II	BRB	Grave	-	Ni	-	-	-	-	-

1	2	3	4	5	6	7	8	9	10	11	12
2	<u>Jars</u>										
2.4	Jar rim sherds										
2.4.1	Jar rim sherd: hole-mouthed										
1519	4032	ED I/II	2.4.1.7	Grave	-	Bi	366	-	-	-	*
2.4.2	Jar rim sherd: short neck										
1520	4032	ED I/II	2.4.2.5	Grave	-	Ei	-	-	-	-	*
2.4.5	Jar sherd: bevelled rim										
1521	4032	ED I/II	2.4.5.1	Grave	-	Ei	363	-	-	-	*
2.4.8	Jar sherd: flat rim										
1522	4032	ED I/II	2.4.8.8	Grave	-	Ei	364	-	-	-	*
5	<u>Spouted jars</u>										
1523	4032	ED I/II	5 8.6.1	Grave	-	Biii	365	-	-	-	*
5.7	Spouted jar sherds: spouts										
1524	4032	ED I/II	5.7	Grave	-	Ci	-	-	-	-	-
1525	4032	ED I/II	5.7	Grave	-	Ei	359	-	-	-	-
1526	4049	ED I/II	5.7 13.2.2	Grave	-	Ei	-	-	-	-	-
5.7.2	Long spouts										
1527	4032	ED I/II	5.7.2	Grave	-	Ei	360	-	-	-	*

1	2	3	4	5	6	7	8	9	10	11	12	
14	<u>Bases</u>											
14.1	Flat bases											
14.1.1	Flat bases: string cut (Footed goblets)											
1528	4032		ED I/II	14.1.1 1.3.1	Grave	-	Bii	368	-	-	-	*
14.1.1	Flat bases: string-cut (Solid-footed goblets)											
1529	4032		ED I/II	14.1.1 1.3.2	Grave	-	Ci	357	-	-	-	*
1530	4032	(5)	ED I/II	14.1.1 1.3.2	Grave	-	Ci	-	-	-	-	-
1531	4032		ED I/II	14.1.1 1.3.2	Grave	-	Ai	358	-	-	-	*
1532	4032		ED I/II	14.1.1 1.3.2	Grave	-	Bi	367	-	-	-	-
1533	4032		ED I/II	14.1.1 1.3.2	Grave	-	Aiii	-	-	-	-	-
1534	4032		ED I/II	14.1.1 1.3.2	Grave	-	Ei	361	-	-	-	*
1535	4032	(4)	ED I/II	14.1.1 1.3.2	Grave	-	Aiv	-	-	-	-	-
14.3	Ring bases											
14.3.1	Ring base: pinched											
1536	4032		ED I/II	14.3.1	Grave	-	Ci	-	-	-	-	-
14.3.4	Ring base: added											
1537	4032		ED I/II	14.3.4	Grave	-	Ci	-	-	-	-	-

1	2	3	4	5	6	7	8	9	10	11	12
ABU SALABIKH: WEST MOUND											
1	<u>Bowls</u>										
1.1	Conical bowls										
1538	5004	(25)	ED I?	1.1	2G 80	-	-	-	-	-	-
1539	5005	(22)	ED I?	1.1	2G 70	-	-	-	-	-	-
1540	5012	(16)	ED I?	1.1	2G 80	-	-	-	-	-	-
1541	5029	(20)	ED I?	1.1	2G 31	-	-	-	-	-	-
1542	5030	(3)	ED I?	1.1	2G 21	-	-	-	-	-	-
1543	5031	(1)	ED I?	1.1	2G 11	-	-	-	-	-	-
1544	5033	(2)	ED I?	1.1	2G 21	-	-	-	-	-	-
1545	5034	(2)	ED I?	1.1	2G 11	-	-	-	-	-	-
1.1	Conical bowls: rim diameter < 15cm										
1546	5212	(8)	ED III	1.1	6F 25 (Area E)	-	Aii	-	-	-	-
1547	5212	(11)	ED III	1.1	6F 25 (Area E)	-	Aiii	-	-	-	-
1548	5212	(17)	ED III	1.1	6F 25 (Area E)	-	Aiv	-	-	-	-
1549	5212	(11)	ED III	1.1	6F 25 (Area E)	-	Bii	-	-	-	-
1550	5212	(13)	ED III	1.1	6F 25 (Area E)	-	Cii	-	-	-	-
1551	5212	(8)	ED III	1.1	6F 25 (Area E)	-	Ciii	-	-	-	-
1552	5411	(23)	ED I	1.1	2G 36d	-	Ei	458	-	24/13	-

1	2	3	4	5	6	7	8	9	10	11	12	
1553	5411	(27)	ED I	1.1	2G 36d	-	Aii	463	-	24/26	54/32	-
1554	5411	(8)	ED I	1.1	2G 36d	-	Ei	465	-	24/31	54/33	-
1555	5412		ED I	1.1	2G 36d	-	Ei	-	-	-	-	-
1556	5600	(2)	M/L. Uruk	1.1	3G 81 all	-	Aii	-	-	-	-	-
1557	5600		M/L. Uruk	1.1	3G 81 all	-	Cii	-	-	-	-	-
1558	5601	(3)	M/L. Uruk	1.1	3G 81 all	-	Aii	-	-	-	-	-
1559	5601	(4)	M/L. Uruk	1.1	3G 81 all	-	Ei	-	-	-	-	-
1560	5602	(6)	M/L. Uruk	1.1	3G 81c	-	Bvi	-	-	-	-	-
1561	5937		L. Uruk?	1.1	3G 60	-	Bii	-	-	-	-	-
1562	5948		L. Uruk?	1.1	3G 61	-	Avi	-	-	-	-	-
1563	5948	(5)	L. Uruk?	1.1	3G 61	-	Cii	-	-	-	-	-
1.1 Conical bowls: rim diameter > 15 cm												
1564	5408		ED I	1.1	3G 36b	-	Aii	434	-	3/1	-	-
1565	5408		ED I	1.1	3G 36b	-	Bi	449	-	3/2	-	-
1566	5408	(41)	ED I	1.1	3G 36b	-	Aii	-	-	-	-	-
1567	5408	(37)	ED I	1.1	3G 36b	-	Bi	-	-	-	-	-
1568	5408	(53)	ED I	1.1	3G 36b	-	Cii	-	-	-	-	-
1569	5408	(7)	ED I	1.1	3G 36b	-	Bii	-	-	-	-	-
1570	5412	(19)	ED I	1.1	3G 36d	-	Avi	-	-	-	-	-
1571	5412	(5)	ED I	1.1	3G 36d	-	Bii	-	-	-	-	-
1572	5412	(27)	ED I	1.1	3G 36d	-	Cii	-	-	-	-	-

1	2	3	4	5	6	7	8	9	10	11	12
1573	5413	(15)	ED I	1.1	2G 36d	-	Aii	-	-	-	-
1574	5413	(18)	ED I	1.1	2G 36d	-	Aiv	-	-	-	-
1575	5413		ED I	1.1	2G 36d	-	Bii	-	-	-	-
1576	5413	(5)	ED I	1.1	2G 36d	-	Cii	-	-	-	-
1577	5416	(10)	ED I	1.1	2G 36b	-	Aii	-	-	-	-
1578	5416	(4)	ED I	1.1	2G 36b	-	Ciii	-	-	-	-
1579	5422	(12)	ED I	1.1	2G 36b	-	Aiv	-	-	-	-
1580	5422	(8)	ED I	1.1	2G 36b	-	Cii	-	-	-	-
1581	5422	(3)	ED I	1.1	2G 36b	-	Ciii	-	-	-	-
1582	5423	(4)	ED I	1.1	2G 36d	-	Aiv	-	-	-	-
1583	5423	(5)	ED I	1.1	2G 36d	-	Avi	-	-	-	-
1584	5523	(3)	E. ED I	1.1	2G 46d	-	Avi	-	-	-	-
1585	5547	(2)	Uruk	1.1	2G 46d	-	Avi	-	-	-	-
1586	5601		M/L. Uruk	1.1	3G 81c	-	Bvi	507	-	1/31	*
1587	5601	(93)	M/L. Uruk	1.1	3G 81c	-	Ai	-	-	-	-
1588	5601	(78)	M/L. Uruk	1.1	3G 81c	-	Avi	-	-	-	-
1589	5601	(68)	M/L. Uruk	1.1	3G 81c	-	Cii	-	-	-	-
1590	5601		M/L. Uruk	1.1 (waster)	3G 81c	-	Niii	-	-	-	-
1591	5602	(21)	M/L. Uruk	1.1	3G 81c	-	Avi	-	-	-	-
1592	5602	(17)	M/L. Uruk	1.1	3G 81c	-	Bvi	-	-	-	-
1593	5602	(5)	M/L. Uruk	1.1	3G 81c	-	Cii	-	-	-	-

1	2	3	4	5	6	7	8	9	10	11	12
1594	5937	(2)	L. Uruk?	1.1	3G 60	-	Cii	-	-	-	-
1595	5939		L. Uruk?	1.1	3G 60	-	Cii	-	-	-	-
1596	5947		L. Uruk?	1.1	3G 61	-	Avi	-	-	-	-
1.2 Transitional bowls											
1.2.1 Transitional bowls: cut rim											
1597	5212		ED III	1.2.1	6F 25 (Area E)	-	Ni	-	-	-	-
1598	5408		ED I	1.2.1	2G 36b	-	Dii	467	-	25/16	- *
1599	5408	(2)	ED I	1.2.1	2G 36b	-	Aii	-	-	-	-
1600	5411		ED I	1.2.1	2G 36d	-	Aiii	464	-	24/29	-
1601	5413	(2)	ED I	1.2.1	2G 36d	-	Aviii	-	-	-	-
1602	5422		ED I	1.2.1	2G 36b	-	Bix	-	-	-	-
1603	5600	(9)	M/L. Uruk	1.2.1	3G 81a11	-	Ni	-	-	-	-
1604	5600	(2)	M/L. Uruk	1.2.1	3G 81a11	-	Nii	-	-	-	-
1605	5601		M/L. Uruk	1.2.1	3G 81c	-	Biii	508	-	1/28	- *
1606	5601	(84)	M/L. Uruk	1.2.1	3G 81c	-	Aiv	-	-	-	-
1607	5601	(98)	M/L. Uruk	1.2.1	3G 81c	-	Aviii	-	-	-	-
1608	5601	(86)	M/L. Uruk	1.2.1	3G 81c	-	Bi	-	-	-	-
1609	5601	(31)	M/L. Uruk	1.2.1	3G 81c	-	Bii	-	-	-	-
1610	5601	(104)	M/L. Uruk	1.2.1	3G 81c	-	Biii	-	-	-	-
1611	5601	(11)	M/L. Uruk	1.2.1	3G 81c	-	Bix	-	-	-	-
1612	5602		M/L. Uruk	1.2.1	3G 81c	-	Aiii	-	-	-	-

1	2	3	4	5	6	7	8	9	10	11	12
1613	5602	(19)	M/L. Uruk	1.2.1	3G 81c	-	Aiv	-	-	-	-
1614	5602	(32)	M/L. Uruk	1.2.1	3G 81c	-	Aviii	-	-	-	-
1615	5602	(26)	M/L. Uruk	1.2.1	3G 81c	-	Bi	-	-	-	-
1616	5602	(7)	M/L. Uruk	1.2.1	3G 81c	-	Bii	-	-	-	-
1617	5602	(79)	M/L. Uruk	1.2.1	3G 81c	-	Bix	-	-	-	-
1618	5940		L. Uruk?	1.2.1	3G 61	-	Ci	-	-	-	-
12.2 Transitional bowls: flared rim											
1619	5411	(2)	ED I	1.2.2	3G 36d	-	Ei	460	-	24/20	-
1620	5550		Uruk	1.2.2	2G 46d	-	Niii	-	-	-	-
1621	5601		M/L. Uruk	1.2.2	3G 81c	-	Ci	496	-	1/29	*
1622	5601	(297)	M/L. Uruk	1.2.2	3G 81c	-	Aviii	-	-	-	-
1623	5601	(67)	M/L. Uruk	1.2.2	3G 81c	-	Ci	-	-	-	-
1624	5602	(58)	M/L. Uruk	1.2.2	3G 81c	-	Aviii	-	-	-	-
1625	5602	(35)	M/L. Uruk	1.2.2	3G 81c	-	Ci	-	-	-	-
1626	5601		M/L. Uruk	1.2.2	3G 81a	-	Ci	-	-	-	-
1.2.3 Transitional bowls: bevelled rim											
1627	5550		Uruk	1.2.3	3G 36d	-	Niii	-	-	-	-
1628	5601	(4)	M/L. Uruk	1.2.3	3G 81c	-	Ci	-	-	-	-
1629	5601	(5)	M/L. Uruk	1.2.3	3G 81c	-	Bix	-	-	-	-
1630	5611	(2)	M/L. Uruk	1.2.3	3G 81a	-	Biii	-	-	-	-

1	2	3	4	5	6	7	8	9	10	11	12
1.3 Goblets											
1.3.2 Solid-footed goblets											
1631	5056		ED I?	1.3.2	2G 13	McAdam, 1983, 69, fig.144 no.82	Aiii	-	-	-	-
1632	5408		ED I	1.3.2	2G 36b	-	Aiv	439	-	2/37	- *
1633	5408	(48)	ED I	1.3.2	2G 36b	-	Aiv	-	-	-	-
1634	5408	(17)	ED I	1.3.2	2G 36b	-	Bii	-	-	-	-
1635	5408	(76)	ED I	1.3.2	2G 36b	-	Cii	-	-	-	-
1636	5411		ED I	1.3.2	2G 36d	-	Aiv	459	-	24/17	54/31 -
1637	5412	(7)	ED I	1.3.2	2G 36d	-	Aiv	-	-	-	-
1638	5412	(6)	ED I	1.3.2	2G 36d	-	Cii	-	-	-	-
1639	5413	(6)	ED I	1.3.2	2G 36d	-	Aiv	-	-	-	-
1640	5413	(2)	ED I	1.3.2	2G 36d	-	Bii	-	-	-	-
1641	5413	(4)	ED I	1.3.2	2G 36d	-	Cii	-	-	-	-
1642	5416		ED I	1.3.2	2G 36b	-	Ci	-	-	-	- *
1643	5416	(6)	ED I	1.3.2	2G 36b	-	Aii	-	-	-	-
1644	5416	(2)	ED I	1.3.2	2G 36b	-	Aiii	-	-	-	-
1645	5416	(7)	ED I	1.3.2	2G 36b	-	Aiv	-	-	-	-
1646	5416	(12)	ED I	1.3.2	2G 36b	-	Avi	-	-	-	-
1647	5416	(5)	ED I	1.3.2	2G 36b	-	Ci	-	-	-	-
1648	5416	(13)	ED I	1.3.2	2G 36b	-	Cii	-	-	-	-
1649	5416		ED I	1.3.2	2G 36b	-	Aii	-	-	-	-
1650	5422	(7)	ED I	1.3.2	2G 36b	-	Aiii	-	-	-	-

1	2	3	4	5	6	7	8	9	10	11	12
1651	5422	(6)	ED I	1.3.2	2G 36b	-	Cii	-	-	-	-
1652	5422	(2)	ED I	1.3.2	2G 36b	-	Hi	-	-	-	-
1653	5423	(3)	ED I	1.3.2	2G 36d	-	Avi	-	-	-	-
1654	5423		E. ED I	1.3.2	2G 36d	-	Cii	-	-	-	-
1655	5601		M/L. Uruk	1.3.2	3G 81c	-	Ci	-	-	-	-
1656	5602	(2)	M/L. Uruk	1.3.2	3G 81c	-	Ci	-	-	-	-
1657	5904		Uruk?	1.3.2 (waster)	3G 80	-	-	-	-	-	-
1658	5924		Uruk?	1.3.2 (waster)	3G 82	McAdam 1983, 57, fig.34 no.4	-	-	-	-	-
Bevel-rim bowls (BRB)											
1659	5004		ED I?	BRB	2G 80	-	-	-	-	-	-
1660	5005	(3)	ED I?	BRB	2G 70	-	Bix	432	-	15/6	-
1661	5012		ED I?	BRB	2G 80	-	-	-	-	-	-
1662	5031		ED I?	BRB	2G 11	-	-	-	-	-	-
1663	5408		ED I	BRB	2G 36b	-	Bii	-	-	-	-
1664	5411	(6)	ED I	BRB	2G 36d	-	Niii	-	-	-	-
1665	5411	(3)	ED I	BRB	2G 36d	-	Ci	-	-	-	-
1666	5412	(2)	ED I	BRB	2G 36d	-	Ni	-	-	-	-
1667	5413	(3)	ED I	BRB	2G 36d	-	Niv	-	-	-	-
1668	5413	(10)	ED I	BRB	2G 36d	-	Ni	-	-	-	-
1669	5422	(2)	ED I	BRB	2G 36b	-	Ni	-	-	-	-
1670	5523	(7)	E. ED I	BRB	2G 46d	-	Aii	-	-	-	-

1	2	3	4	5	6	7	8	9	10	11	12
1671	5523	(13)	E. ED I	BRB	2G 46d	-	Ei	-	-	-	-
1672	5523	(15)	E. ED I	BRB	2G 46d	-	Nvi	-	-	-	-
1673	5544	(13)	Uruk	BRB	2G 46d	-	Ci	-	-	-	-
1674	5544	(5)	Uruk	BRB	2G 46d	-	Niv	-	-	-	-
1675	5547	(17)	Uruk	BRB	2G 46d	-	Niii	-	-	-	-
1676	5547	(5)	Uruk	BRB	2G 46d	-	Di	-	-	-	-
1677	5547	(2)	Uruk	BRB	2G 46d	-	Nv	-	-	-	-
1678	5550		Uruk	BRB	2G 46d	-	Aii	483	-	-	-
1679	5550	(4)	Uruk	BRB	2G 46d	-	Ei	-	-	-	-
1680	5550	(21)	Uruk	BRB	2G 46d	-	Ni	-	-	-	-
1681	5550	(3)	Uruk	BRB	2G 46d	-	Bi	-	-	-	-
1682	5551	(7)	Uruk	BRB	2G 46d	-	Aii	-	-	-	-
1683	5551	(16)	Uruk	BRB	2G 46d	-	Bix	-	-	-	-
1684	5551	(4)	Uruk	BRB	2G 46d	-	Ei	-	-	-	-
1685	5551	(2)	Uruk	BRB	2G 46d	-	Nv	-	-	-	-
1686	5553	(9)	Uruk	BRB	2G 46d	-	Bi	-	-	-	-
1687	5553		Uruk	BRB	2G 46d	-	Niv	-	-	-	-
1688	5600	(4)	M/L. Uruk	BRB	3G 81all	-	Ni	-	-	-	-
1689	5601		M/L. Uruk	BRB	3G 81c	-	Ci	524	-	1/30	*
1690	5601	(17)	M/L. Uruk	BRB	3G 81c	-	Ci	-	-	-	-
1691	5601	(124)	M/L. Uruk	BRB	3G 81c	-	Ni	-	-	-	-
1692	5601	(71)	M/L. Uruk	BRB	3G 81c	-	Niii	-	-	-	-

1	2	3	4	5	6	7	8	9	10	11	12
1693	5601	(58)	M/L. Uruk	BRB	3G 81c	-	Niv	-	-	-	-
1694	5602	(9)	M/L. Uruk	BRB	3G 81c	-	Bix	-	-	-	-
1695	5602	(6)	M/L. Uruk	BRB	3G 81c	-	Ci	-	-	-	-
1696	5602	(15)	M/L. Uruk	BRB	3G 81c	-	Ni	-	-	-	-
1697	5602	(13)	M/L. Uruk	BRB	3G 81c	-	Niii	-	-	-	-
1698	5611	(6)	M/L. Uruk	BRB	3G 81a	-	Aii	-	-	-	-
1699	5611	(13)	M/L. Uruk	BRB	3G 81a	-	Ci	-	-	-	-
1700	5611	(34)	M/L. Uruk	BRB	3G 81a	-	Ni	-	-	-	-
1701	5611	(27)	M/L. Uruk	BRB	3G 81a	-	Niii	-	-	-	-
1702	5932		Uruk?	BRB	3G 83	-	Ni	-	-	-	-
1703	5937	(19)	L. Uruk?	BRB	3G 60	-	Ni	-	-	-	-
1704	5937	(2)	L. Uruk?	BRB	3G 60	-	Niii	-	-	-	-
1705	5937	(36)	L. Uruk?	BRB	3G 60	-	Nv	-	-	-	-
1706	5937	(9)	L. Uruk?	BRB	3G 60	-	Nvi	-	-	-	-
1707	5939	(37)	L. Uruk?	BRB	3G 60	-	Ni	-	-	-	-
1708	5939	(2)	L. Uruk?	BRB	3G 60	-	Niv	-	-	-	-
1709	5939	(31)	L. Uruk?	BRB	3G 60	-	Nv	-	-	-	-
1710	5939	(19)	L. Uruk?	BRB	3G 60	-	Nvi	-	-	-	-
1711	5940	(7)	L. Uruk?	BRB	3G 60	-	Nv	-	-	-	-
1712	5941	(47)	L. Uruk?	BRB (wasters)	3G 61	-	Nv	-	-	-	-
1713	5942	(20)	L. Uruk?	BRB (wasters)	3G 61	-	Nv	-	-	-	-

1	2	3	4	5	6	7	8	9	10	11	12
1714	5943	(4)	L. Uruk?	BRB	3G 61	-	Nv	-	-	-	-
1715	5943	(22)	L. Uruk?	BRB (wasters)	3G 61	-	Nvi	-	-	-	-
1716	5944	(16)	L. Uruk?	BRB (wasters)	3G 61	-	Nv	-	-	-	-
1717	5945	(11)	L. Uruk?	BRB (wasters)	3G 61	-	Nv	-	-	-	-
1718	5946	(16)	L. Uruk?	BRB	3G 61	-	Ni	-	-	-	-
1719	5946	(21)	L. Uruk?	BRB	3G 61	-	Nv	-	-	-	-
1720	5946	(37)	L. Uruk?	BRB	3G 61	-	Nvi	-	-	-	-
1721	5947	(7)	L. Uruk?	BRB	3G 61	-	Ni	-	-	-	-
1722	5948	(27)	L. Uruk?	BRB	3G 61	-	Ni	-	-	-	-
1723	5948	(12)	L. Uruk?	BRB	3G 61	-	Niii	-	-	-	-
1724	5948	(15)	L. Uruk?	BRB	3G 61	-	Nvi	-	-	-	-
1725	5547		Uruk	BRB 13.3.1	2G 46d	-	Bi	-	-	-	-
1.5 Large bowls: flat base											
1.5.2 Dish											
1726	5905		Uruk?	1.5.2 1.14.7.4	3G 80	McAdam 1983, 61, fig.50 no.15	Bi	-	-	-	-
1.7 Ring-based bowls											
1.7.2 Ring-based bowl: small											
1727	5212	: 6F 25 : 20	ED III	1.7.2	6F 25 (Area E)	-	Avii	-	-	-	*
1.8 Band/collar-rim bowl											
1728	5413	: 2G 36 : 161	ED I	1.8 1.16.4	2G 36d	-	Aii	-	-	-	-

1	2	3	4	5	6	7	8	9	10	11	12
1.9 Sieve bowls											
1729	5602	L. Uruk	1.9 14.3.1	3G 81c	-	Avi	-	-	-	-	-
1.9.3 'ladle'											
1730	5608	ED I	1.9.3	2G 36b	-	Ei	442	-	2/30	-	-
1.14 Bowl rim sherds											
1.14.1 Bowl sherds: fine; plain rim											
1731	5601	M/L. Uruk	1.14.1.1	3G 81c	-	Ci	497	-	1/27	-	*
1732	5601	(7)	M/L. Uruk	1.14.1.1	3G 81c	-	Ci	-	-	-	-
1733	5602	(2)	M/L. Uruk	1.14.1.1	3G 81c	-	Ci	-	-	-	-
1734	5940	(3)	L. Uruk?	1.14.1.1	3G 61	-	Ci	-	-	-	-
1735	5941	(6)	L. Uruk?	1.14.1.1	3G 61	-	Ci	-	-	-	-
1736	5943	(5)	L. Uruk?	1.14.1.1	3G 61	-	Ci	-	-	-	-
1737	5944	(4)	L. Uruk?	1.14.1.1	3G 61	-	Ii	-	-	-	-
1738	5945		L. Uruk?	1.14.1.1	3G 61	-	Ii	-	-	-	-
1739	5946	(7)	L. Uruk?	1.14.1.1	3G 61	-	Ii	-	-	-	-
1740	5947	(3)	L. Uruk?	1.14.1.1	3G 61	-	Ii	-	-	-	-
1741	5601	M/L. Uruk	1.14.1.1 13.2.1	3G 81c	-	Ci	-	-	-	-	-
1742	5523	E. ED I	1.14.1.2	2G 46d	-	Niii	-	-	-	-	-
1743	5601	M/L. Uruk	1.14.1.2	3G 81c	-	Ci	-	-	-	-	-
1744	5935	Uruk?	1.14.1.2	3G 93	McAdam 1983, 57, fig.32 no.2; 20	Cii	-	-	-	-	-
1745	5937	L. Uruk?	1.14.1.2	3G 60	-	Aiv	-	-	-	-	-

1	2	3	4	5	6	7	8	9	10	11	12
1746	5092	ED I	1.14.1.3 (waster)	2G 55	McAdam 1983, 69, fig.147 no.83	Bi?	-	-	-	-	-
1.14.2 Bowl sherds: fine; rolled rim											
1747	5034	ED I	1.14.2.1	2G 11	-	-	-	-	-	-	-
1748	5601	M/L. Uruk	1.14.2.1	3G 81c	-	Cii	-	-	-	-	-
1749	5913	Uruk?	1.14.2.1	3G 70	McAdam 1983, 57, fig.38 no.7	Ciii	-	-	-	-	-
1750	5913	Uruk?	1.14.2.1	3G 70	McAdam 1983, 57, fig.37 no.7	Aii	-	-	-	-	-
1751	5601	M/L? Uruk	1.14.2.2	3G 81c	-	Ciii	-	-	-	-	-
1752	5602	M/L. Uruk	1.14.2.2	3G 81c	-	Ei	-	-	-	-	-
1753	5212	ED III	1.14.2.3	6F 25 (Area E)	-	Aiv	-	-	-	-	-
1.14.3 Bowl sherds: medium; plain rim											
1754	5212	(2)	ED III	1.14.3.1	6F 25 (Area E)	Aiv	-	-	-	-	-
1755	5408		ED I	1.14.3.1	2G 36b	Aiv	-	-	-	-	*
1756	5408		ED I	1.14.3.1	2G 36b	Eiii	445	-	6/11	-	*
1757	5408		ED I	1.14.3.1	2G 36b	Ei	441	-	6/12	-	*
1758	5408	(2)	ED I	1.14.3.1	2G 36b	Eiii	-	-	-	-	-
1759	5411		ED I	1.14.3.1	2G 36d	Dii	462	-	24/25	54/29 54/30	-
1760	5422		ED I	1.14.3.1	2G 36b	Cii	-	-	-	-	-
1761	5601	(3)	M/L. Uruk	1.14.3.1	3G 81c	Dii	-	-	-	-	-
1762	5926		Uruk?	1.14.3.1	3G 92	Biii	-	-	-	-	-
1763	5937		L. Uruk?	1.14.3.1	3G 60	Cii	-	-	-	-	-

1	2	3	4	5	6	7	8	9	10	11	12
1764	5212		ED III	1.14.3.1 1.11?	6F 25	-	Aii	-	-	-	-
1765	5413	(3)	ED I	1.14.3.1 8.17.2	2G 36d	-	Ei	-	-	-	-
1766	5423		ED I	1.14.3.2	2G 36d	-	Eiii	-	-	-	-
1767	5943		L. Uruk?	1.14.3.3	3G 61	-	Ci	-	-	-	-
1768	5909		Uruk?	1.14.3.3	3G 60	McAdam 1983, 57, fig.36 no.6	Bi	-	-	-	-
1769	5924		Uruk?	1.14.3.3	3G 82	-	Ii	-	-	-	-
1770	5934		Uruk?	1.14.3.3 (waster)	3G 93	-	-	-	-	-	-
1771	5416		ED I	1.14.3.3 8.17.2	2G 36b	-	Avii	-	-	-	*
1772	5029	(2)	ED I?	1.14.3.4	2G 31	-	-	-	-	-	-
1773	5600	(2)	M/L. Uruk	1.14.3.4	3G 81a11	-	Bii	-	-	-	-
1774	5904		Uruk	1.14.3.4	3G 80	McAdam 1983, 57, fig.40 no.8	Ciii	-	-	-	-
1775	5408		ED I	1.14.3.6	2G 36b	-	Hi	455	-	2/28 6/19	*
1.14.4 Bowl sherd: medium; cut rim											
1776	5916		Uruk?	1.14.4	3G 50	-	Jii	-	-	-	-
1.14.5 Bowl sherds: medium; dished rim											
1777	5004		ED I?	1.14.5.1	2G 80	-	-	-	-	-	-
1778	5601		M/L. Uruk	1.14.5.1	3G 81c	-	Bi	-	-	-	-
1779	5408		ED I	1.14.5.2 small bowl	2G 36b	-	Ciii	-	-	-	-
1780	5408		ED I	1.14.5.2 large bowl	2G 36b	-	Avii	-	-	-	-

1	2	3	4	5	6	7	8	9	10	11	12
1.14.6 Bowl sherds: medium; bevelled/everted rim											
1781	5416		ED I	1.14.6.1	2G 36b	-	Li	-	-	-	-
1782	5212	(2)	ED III	1.14.6.3	6F 25 (Area E)	-	Aiv	-	-	-	-
1783	5408		ED I	1.14.6.3	2G 36b	-	Eiii	-	-	-	-
1784	5412		ED I	1.14.6.3	2G 36d	-	Avii	-	-	-	-
1785	5412	(2)	ED I	1.14.6.3	2G 36d	-	Aiv	-	-	-	-
1786	5413	(2)	ED I	1.14.6.3	2G 36d	-	Ei	-	-	-	-
1787	5601		M/L. Uruk	1.14.6.3	3G 81c	-	Hii	-	-	-	-
1788	5212		ED III	1.14.6.4	6F 25 (Area E)	-	Bi	-	-	-	-
1789	5601		M/L. Uruk	1.14.6.4	3G 81c	-	Ci	-	-	-	-
1790	5212		ED III	1.14.6.5	6F 25 (Area E)	-	Aiv	-	-	-	-
1791	5413		ED I	1.14.6.5	2G 36d	-	Eiii	-	-	-	-
1792	5601		M/L. Uruk	1.14.6.5	3G 81c	-	Aix	-	-	-	-
1793	5212		ED III	1.14.6.5 1.16.2	6F 25 (Area E)	-	Ciii	-	-	-	*
1794	5601		M/L. Uruk	1.14.6.7	3G 81c	-	Bi	-	-	-	-
1795	5601		M/L. Uruk	1.14.6.9	3G 81c	-	Eii	-	-	-	-
1796	5602		M/L. Uruk	1.14.6.9	3G 81c	-	Eiii	-	-	-	-
1.14.7 Bowl sherds: large rims											
1797	5408		ED I	1.14.7.1	2G 36b	-	Ei	-	-	-	*
1798	5416		ED I	1.14.7.1	2G 36b	-	Ei	-	-	-	-

1	2	3	4	5	6	7	8	9	10	11	12
1799	5948	L. Uruk?	1.14.7.1 (waster)	3G 61	-	-	559	-	4/3	-	-
1800	5948	L. Uruk?	1.14.7.1	3G 61	-	Cii	-	-	-	-	-
1801	5411	ED I	1.14.7.2 8.4.1.1	2G 36d	-	Aiv	-	-	-	-	-
1802	5030	ED I?	1.14.7.2 1.15.10	2G 21	-	Aviii	-	-	-	-	-
1803	5029	ED I?	1.14.7.3	2G 31	-	Dii	-	-	-	-	-
1804	5408	ED I	1.14.7.6.1	2G 36b	-	Ei	-	-	-	-	-
1.14.8 Vertical-sided bowls (see also 1.17)											
1805	5523	E. ED I	1.14.8.1	2G 46d	-	Dii	-	-	-	-	-
1806	5094	ED I?	1.14.8.2	2G 45	McAdam 1983, 71, fig.162 no.89	Biii	-	-	-	-	-
1807	5553	Uruk	1.14.8.3	2G 46d	-	Ci	-	-	-	-	-
1808	5550	Uruk	1.14.8.4	2G 46d	-	Ii	-	-	-	-	-
1809	5551	Uruk	1.14.8.4	2G 46d	-	Bi	-	-	-	-	-
1810	5923	Uruk?	1.14.8.4	3G 72	McAdam 1983, 57, fig.48 no.13	Ii	-	-	-	-	-
1811	5179	ED I?	1.14.8.5	2G 97	McAdam 1983, 71, fig.161 no.88	Ii	-	-	-	-	-
1812	5923	Uruk?	1.14.8.5	3G 72	-	Bi	-	-	-	-	-
1813	5921	Uruk?	1.14.8.6	3G 62	c.f. McAdam 1983, 71, fig.160 no.87	Bi	-	-	-	-	-
1814	5908	Uruk?	1.14.8.6 1.16.1	3G 60	McAdam 1983, 61, fig.54 nos.18, 19	Hv	-	-	-	-	-
1815	5550	Uruk	1.14.8.7	2G 46d	-	Biii	-	-	-	-	*
1816	5550	Uruk	1.14.8.7	2G 46d	-	Ii	485	-	0/13	-	-
1817	5550	(2)	Uruk	1.14.8.7	2G 46d	-	Biii	-	-	-	-

1	2	3	4	5	6	7	8	9	10	11	12
1818	5601	M/L. Uruk	1.14.8.9	3G 81c	-	Bi	-	-	-	-	-
1819	5611	M/L. Uruk	1.14.8.9	3G 81a	-	Biv	-	-	-	-	-
1820	5611	M/L. Uruk	1.14.8.9 13.3.4	3G 81a	-	Aix	-	-	-	-	-
1.15 Large bowl sherds: coarse ware rims											
1821	5029	ED I?	1.15.1	2G 31	-	Qi	-	-	-	-	-
1822	5034	ED I?	1.15.1	2G 11	-	Qiii	-	-	-	-	-
1823	5423	ED I	1.15.2	2G 36d	-	Qi	-	-	-	-	-
1824	5601	M/L. Uruk	1.15.2	3G 81c	-	Qiii	-	-	-	-	-
1825	5408	ED I	1.15.3	2G 36b	-	Pii	-	-	-	-	-
1826	5408	ED I	1.15.3 1.16.2	2G 36b	-	Qii	-	-	-	-	-
1827	5408	ED I	1.15.4	2G 36b	-	Qi	-	-	-	-	*
1828	5411	ED I	1.15.4	2G 36d	-	Qi	-	-	-	-	-
1829	5416	ED I	1.15.4	2G 36b	-	Qi	-	-	-	-	-
1830	5408	ED I	1.15.4.1	2G 36b	-	Qii	-	-	-	-	*
1831	5412	ED I	1.15.4.1	2G 36d	-	Qii	-	-	-	-	-
1832	5601	M/L. Uruk	1.15.5	3G 81c	-	Pii	-	-	-	-	-
1833	5408	ED I	1.15.7	2G 36b	-	Pii	-	-	-	-	-
1834	5423	ED I	1.15.7	2G 36d	-	Qiii	-	-	-	-	-
1835	5408	ED I	1.15.8	2G 36b	-	Qi	-	-	-	-	*
1836	5030	ED I?	1.15.9	2G 21	-	Qii	-	-	-	-	-
1837	5550	Uruk	1.15.9	2G 46d	-	Qii	-	-	-	-	-

1	2	3	4	5	6	7	8	9	10	11	12
1838	5107	ED I	1.15.9	2G 76	McAdam 1983, 81, fig.276 no.161	Qv	-	-	-	-	-
1839	5601	M/L. Uruk	1.15.9 8.16.6	3G 81c	-	Qi	555	-	3/24	-	-
1840	5412	ED I	1.15.10	2G 36d	-	Pii	-	-	-	-	*
1841	5601	M/L. Uruk	1.15.10	3G 81c	-	Qiii	-	-	-	-	-
1842	5937	L. Uruk?	1.15.10	3G 60	-	Qiii	-	-	-	-	-
1843	5059	ED I?	1.15.11	2G 33	McAdam 1983, 81, fig.275 no.161	Qi	-	-	-	-	-
1844	5611	M/L. Uruk	1.15.11	3G 81a	-	Qii	-	-	-	-	-
1.17 Spouted bowls											
1845	5411	ED I	1.17	2G 36d	-	Bi	-	-	-	-	-
1846	5611	M/L. Uruk	1.17	3G 81a	-	Dii	-	-	-	-	-
1847	5523	: 2G 46 : 67	E. ED I	1.17 13.3.2	2G 46d	Postgate and Moon 1982, 113, fig.4 no.10	Bii	-	-	-	-
2 Jars											
2.1 Small jars											
1848	5600	M/L. Uruk	2.1	3G 81all	-	Dii	-	-	-	-	-
1849	5601	M/L. Uruk	2.1	3G 81c	-	Ci	-	-	-	-	-
1850	5601	M/L. Uruk	2.1 2.4.2.1	3G 81c	-	Di	-	-	-	-	-
1851	5901	Uruk?	2.1 2.4.2.3	3G 90	c.f. McAdam 1983, 61, fig.58 no.25	Ai	-	-	-	-	-
1852	5408	ED I	2.1 2.4.3.2	2G 36b	-	Mi	476	-	25/11	-	*
1853	5913	Uruk?	2.1 8.3.1 8.3.3	3G 70	McAdam 1983, 63, fig.92 no.51; 69	Hii	-	-	-	-	-

1	2	3	4	5	6	7	8	9	10	11	12	
2.1.3 Small jars: ring base												
1854	5611	M/L. Uruk	2.1.3	3G 81a	-	Dii	-	-	-	-	-	
1855	5611	M/L. Uruk	2.1.3	3G 81a	-	Hi	-	-	-	-	-	
1856	5611	M/L. Uruk	2.1.3 8.3.3	3G 81a	-	Hx	-	-	-	-	-	
1857	5611	M/L. Uruk	2.1.3 8.3.3	3G 81a	-	Hxii	-	-	-	-	-	
1858	5912	Uruk?	2.1.3 8.3.3	3G 70	-	Hii	-	-	-	-	-	
1859	5180	ED I?	2.1.3 8.8.3	2G 98	McAdam 1983, 75, fig.206 no.127; 148	Biii	-	-	-	-	-	
2.2 Medium jars												
1860	5408	ED I	2.2 2.4.3.2	2G 36b	-	Bi	-	-	-	-	*	
1861	5408	ED I	2.2 8.20 8.4.1	2G 36b	-	Bi	-	-	-	-	-	
1862	5408	ED I	2.2 8.20 8.4.2.1	2G 36b	-	Eiii	-	-	-	-	-	
2.2.1 Medium jars: round base												
1863	5212	: 6F 25 : 23	ED III	2.2.1.2	6F 25	-	Lii	474	-	25/14	-	*
1864	5212	: 6F 25 : 25	ED III	2.2.1.5 2.4.2.2	6F 25	-	Bi	-	-	-	-	*
2.3 Large jars												
1865	5550		Uruk	2.3	2G 46d	-	Miv	-	-	-	-	-
1866	5550		Uruk	2.3	2G 46d	-	Liii	487	-	5/11	-	-
1867	5942	(6)	L. Uruk?	2.3	3G 61	-	Bii	-	-	-	-	-

1	2	3	4	5	6	7	8	9	10	11	12
1868	5047	ED I?	2.3 8.6.2	2G 32	McAdam 1983, 79, fig.248 no.149	Hii	-	-	-	-	-
1869	5212 : 6F 25 : 22	ED III	2.3.3	6F 25 (Area E)	-	Ciii	-	-	-	-	-
2.4 Jar rim sherds											
2.4.1 Jar rim sherds: hole-mouthed											
1870	5004	ED I?	2.4.1	2G 80	-	-	-	-	-	-	-
1871	5408	ED I	2.4.1.1	2G 36b	-	Bi	-	-	-	-	-
1872	5413	ED I	2.4.1.1	2G 36d	-	Avi	-	-	-	-	-
1873	5601	M/L. Uruk	2.4.1.1	3G 81c	-	Ci	-	-	-	-	-
1874	5601	M/L. Uruk	2.4.1.1	3G 81c	-	Bii	-	-	-	-	-
1875	5907	Uruk?	2.4.1.1 8.8.1	3G 81	McAdam 1983, 65, fig.114 no.69	Avii	-	-	-	-	-
1876	5005	ED I?	2.4.1.2	2G 70	-	Mii	-	-	-	-	-
1877	5005	ED I?	2.4.1.2	2G 70	-	Aiv	-	-	-	-	-
1878	5030	ED I?	2.4.1.2	2G 21	-	-	-	-	-	-	-
1879	5212	ED III	2.4.1.2	6F 25 (Area E)	-	Mii	-	-	-	-	-
1880	5422	ED I	2.4.1.2	2G 36d	-	Miii	-	-	-	-	-
1881	5601	M/L. Uruk	2.4.1.2	3G 81c	-	Bi	504	-	1/17	-	*
1882	5523	E. ED I	2.4.1.2	2G 46d	-	Mvii	479	-	4/23	-	-
1883	5411	ED I	2.4.1.2 8.6.7	2G 36d	-	Diii	-	-	-	-	-
1884	5601 (3)	M/L. Uruk	2.4.1.3	3G 81c	-	Ci	-	-	-	-	-
1885	5948	L. Uruk?	2.4.1.3 8.6.8	3G 61	-	Ei	-	-	-	-	-

1	2	3	4	5	6	7	8	9	10	11	12
1886	5601	M/L. Uruk	2.4.1.4	3G 81c	-	Ci	-	-	-	-	-
1887	5601	M/L. Uruk	2.4.1.5	3G 81c	-	Eii	-	-	-	-	-
1888	5412	ED I	2.4.1.6	2G 36d	-	Mviii	-	-	-	-	*
1889	5412	ED I	2.4.1.6	2G 36d	-	Dii	-	-	-	-	*
1890	5553	Uruk	2.4.1.6	2G 46d	-	Bii	-	-	-	-	-
1891	5408	ED I	2.4.1.6 8.4.1	2G 36b	-	Eiii	-	-	-	-	-
1892	5905	Uruk?	2.4.1.6 8.4.1.4 8.5.2	3G 80	McAdam 1983, 63, fig.82 no.44; 56; 68	Avii	-	-	-	-	-
1893	5408	ED I	2.4.1.6 8.6.4	2G 36b	-	Avii	-	-	-	-	-
1894	5408	ED I	2.4.1.6 8.7.1	2G 36b	-	Eiii	-	-	-	-	-
1895	5411	ED I	2.4.1.6 8.7.1	2G 36d	-	Eiii	-	-	-	-	-
1896	5411 : 2G 36 : 179	ED I	2.4.1.6 8.7.1	2G 36d	-	Aiv	-	-	-	-	*
2.4.2 Jar rim sherds: short neck											
1897	5004	ED I?	2.4.2.1	2G 80	-	Ei	-	-	-	-	-
1898	5005 (1)	ED I?	2.4.2.1	2G 70	-	-	-	-	-	-	-
1899	5029	ED I?	2.4.2.1	2G 31	-	Ci	-	-	-	-	-
1900	5031 (2)	ED I?	2.4.2.1	2G 11	-	Ei	-	-	-	-	-
1901	5212 (2)	ED III	2.4.2.1	6F 25 (Area E)	-	Bi	-	-	-	-	-
1902	5408	ED I	2.4.2.1	2G 36b	-	Bi	-	-	-	-	-
1903	5411	ED I	2.4.2.1	2G 36d	-	Ci	471	-	25/5	54/35	-

1	2	3	4	5	6	7	8	9	10	11	12
1904	5423	(2)	ED I	2.4.2.1	2G 36d	-	Eiii	-	-	-	-
1905	5544		Uruk	2.4.2.1	2G 46d	-	Aix	-	-	-	-
1906	5601		M/L. Uruk	2.4.2.1	3G 81c	-	Ci	501	-	1/25	*
1907	5601		M/L. Uruk	2.4.2.1	3G 81c	-	Cii	503	-	1/20 1/21	*
1908	5601		M/L. Uruk	2.4.2.1	3G 81c	-	Bi	505	-	1/16	*
1909	5601	(5)	M/L. Uruk	2.4.2.1	3G 81c	-	Bi	-	-	-	-
1910	5601		M/L. Uruk	2.4.2.1	3G 81c	-	Hiii	537	-	1/13	-
1911	5937		L. Uruk?	2.4.2.1	3G 60	-	Bi	-	-	-	-
1912	5946		L. Uruk?	2.4.2.1	3G 61	-	Hix	-	-	-	-
1913	5601		M/L. Uruk	2.4.2.1 8.6.1	3G 81c	-	Hix	547	-	3/21	*
1914	5423		ED I	2.4.2.1 8.8.1	2G 36d	-	Avii	-	-	-	-
1915	5423		ED I	2.4.2.1 8.9.2	2G 36d	-	Ci	-	-	-	-
1916	5408		ED I	2.4.2.2	2G 36b	-	Bi	-	-	-	-
1917	5411		ED I	2.4.2.2	2G 36d	-	Mv	561	-	24/12	54/28 *
1918	5544		Uruk	2.4.2.2	2G 46d	-	Miv	-	-	-	*
1919	5601	(3)	M/L. Uruk	2.4.2.2	3G 81c	-	Aix	-	-	-	-
1920	5601		M/L. Uruk	2.4.2.2	3G 81c	-	Hij	534	-	6/5	54/18 -
1921	5602		M/L. Uruk	2.4.2.2	3G 81c	-	Hxiii	552	-	1/36 1/37	54/25 -
1922	5925		Uruk?	2.4.2.2 8.8.1	3G 82	McAdam 1983, 61, fig.72 no.36; 65	Jii	-	-	-	-

1	2	3	4	5	6	7	8	9	10	11	12
1923	5029		ED I?	2.4.2.3	2G 31	-	Mii	-	-	-	-
1924	5416		ED I	2.4.2.3	2G 36b	-	Bii	-	-	-	-
1925	5601		M/L. Uruk	2.4.2.3	3G 81c	-	Aix	-	-	-	-
1926	5601		M/L. Uruk	2.4.2.3	3G 81c	-	Ei	511	-	1/19	- *
1927	5408		ED I	2.4.2.3 8.8.1	2G 36b	-	Bi	451	-	4/13	- *
1928	5601		M/L. Uruk	2.4.2.4	3G 81c	-	Ei	510	-	1/19	- *
1929	5946		L. Uruk?	2.4.2.4	3G 61	-	Hiii	-	-	-	-
1930	5411		ED I	2.4.2.5	2G 36d	-	Miii	477	-	24/9	54/27 *
1931	5411	(5)	ED I	2.4.2.5	2G 36d	-	Miii	-	-	-	-
1932	5422		ED I	2.4.2.5	2G 36d	-	Miii	-	-	-	-
1933	5553		Uruk	2.4.2.5	2G 46d	-	Miv	-	-	-	-
1934	5600		M/L. Uruk	2.4.2.5	3G 81a11	-	Miv	493	-	2/6	54/4 54/5 *
1935	5601		M/L. Uruk	2.4.2.5	3G 81c	-	Cii	520	-	3/15	54/6 *
1936	5601		M/L. Uruk	2.4.2.5	3G 81c	-	Ei	-	-	1/18	- *
1937	5601	(3)	M/L. Uruk	2.4.2.5	3G 81c	-	Eiii	-	-	-	-
1938	5601		M/L. Uruk	2.4.2.5	3G 81c	-	Hxii	551	-	2/22	54/17 -
1939	5611	: 3G 81 : 235	M/L. Uruk	2.4.2.5	3G 81a	-	Mvii	-	-	-	-
1940	5923		Uruk?	2.4.2.5	3G 72	-	Bii	-	-	-	- *
1941	5925		Uruk?	2.4.2.5 (waster)	3G 82	McAdam 1983, 63, fig.73 no.38; 70	Bi	-	-	-	- *
1942	5911		Uruk?	2.4.2.5 8.6.2 8.9.1	3G 61	McAdam 1983, 61, fig.71 no.36; 65	Avii	-	-	-	-

1	2	3	4	5	6	7	8	9	10	11	12
1943	5550		Uruk	2.4.2.6	2G 46d	-	Hiii	-	-	-	-
1944	5601		M/L. Uruk	2.4.2.6	3G 81c	-	Aix	-	-	-	-
1945	5601	(4)	M/L. Uruk	2.4.2.6	3G 81c	-	Cii	-	-	-	-
1946	5601		M/L. Uruk	2.4.2.6	3G 81c	-	Hviii	546	-	2/20	54/19
1947	5601	(4)	M/L. Uruk	2.4.2.6	3G 81c	-	Hviii	-	-	-	-
1948	5948		L. Uruk?	2.4.2.6	3G 61	-	Eiii	-	-	-	-
1949	5601		M/L. Uruk	2.4.2.6 8.5.1	3G 81c	-	Hvii	545	-	5/25	54/23
1950	5413		ED I	2.4.2.6 8.9.2	2G 36d	-	Ei	-	-	-	-
1951	5601		M/L. Uruk	2.4.2.6 13.2.1	3G 81c	-	Di	-	-	-	*
1952	5523		E. ED I	2.4.2.8	2G 46d	-	Jii	-	-	-	-
1953	5551		Uruk	2.4.2.8	2G 46d	-	Biii	-	-	-	-
1954	5601		M/L. Uruk	2.4.2.8	3G 81c	-	Hix	549	-	2/25	54/16
1955	5601		M/L. Uruk	2.4.2.8	3G 81c	-	Hviii	-	-	-	-
1956	5601		M/L. Uruk	2.4.2.8	3G 81c	-	Hvi	544	-	5/32	-
1957	5601	(2)	M/L. Uruk	2.4.2.8	3G 81c	-	Hvii	-	-	-	-
1958	5413		ED I	2.4.2.9	2G 36d	-	Bi	-	-	-	-
1959	5422		ED I	2.4.2.9	2G 36b	-	Ei	-	-	-	-
1960	5551		Uruk	2.4.2.9	2G 46d	-	Biii	-	-	-	-
1961	5916		Uruk?	2.4.2.9 13.1.1	3G 50	McAdam 1983, 63, fig.83 no.45	Hx	-	-	-	-
1962	5601		M/L. Uruk	2.4.2.9 13.1.1	3G 81c	-	Hvi	-	-	-	-

1	2	3	4	5	6	7	8	9	10	11	12
1963	5411	(2)	ED I	2.4.2.10	2G 36d	-	Ei	-	-	-	-
1964	5601		M/L. Uruk	2.4.2.10	3G 81c	-	Hx	548	-	2/23	54/14
1965	5601		M/L. Uruk	2.4.2.11	3G 81c	-	Dii	495	-	3/18	*
1966	5905		Uruk?	2.4.2.12	3G 80	McAdam 1983, 63, fig.86 no.47	Aiv	-	-	-	-
2.4.3 Jar rim sherds: long neck											
1967	5031		ED I?	2.4.3.1	2G 11	-	Bi	-	-	-	-
1968	5212	(5)	ED III	2.4.3.1	6F 25	-	Aiv	-	-	-	-
1969	5408		ED I	2.4.3.1	2G 36b	-	Bi	452	-	3/6	*
1970	5411		ED I	2.4.3.1	2G 36d	-	Eiii	-	-	-	-
1971	5413		ED I	2.4.3	2G 36d	-	Aiv	-	-	-	-
1972	5413		ED I	2.4.3.1	2G 36d	-	Diii	-	-	-	-
1973	5423		ED I	2.4.3.1	2G 36d	-	Cii	-	-	-	*
1974	5601		M/L. Uruk	2.4.3.1	3G 81c	-	Hiv	543	-	2/18 5/22	54/21
1975	5029		ED I?	2.4.3.2	2G 31	-	Cii	-	-	-	-
1976	5544		Uruk?	2.4.3.2	2G 46d	-	Hx	-	-	-	-
1977	5547		Uruk	2.4.3.2	2G 46d	-	Bii	-	-	-	-
1978	5601		M/L. Uruk	2.4.3.2	3G 81c	-	Bi	-	-	-	-
1979	5090		ED I?	2.4.3.2 8.4.2.2 8.6.9 8.20	2G 65	McAdam 1983, 75, fig.210 no.131; 149	Aii	-	-	-	-
1980	5905		Uruk?	2.4.3.2 8.5.2	3G 80	McAdam 1983, 63, fig.74 no.39; 68	Bi	-	-	-	-

1	2	3	4	5	6	7	8	9	10	11	12
1981	5943	L. Uruk?	2.4.3.2 8.6.2.1	3G 61	-	Iii	558	-	4/5	-	-
1982	5412	ED I	2.4.3.2 8.9.2	2G 36d	-	Avii	-	-	-	-	-
1983	5926	Uruk?	2.4.3.2 8.9.2	2G 92	McAdam 1983, 61, fig.70 no.36; 64	Ax	-	-	-	-	-
1984	5939	L. Uruk?	2.4.3.2.1	3G 60	-	Dii	-	-	-	-	-
1985	5408	ED I	2.4.3.3	2G 36b	-	Bi	-	-	-	-	-
1986	5412	ED I	2.4.3.3 8.9.2	2G 36d	-	Ax	-	-	-	-	-
1987	5601	M/L. Uruk	2.4.3.4	3G 81c	-	Aix	-	-	-	-	*
1988	5601	M/L. Uruk	2.4.3.4	3G 81c	-	Ci	-	-	-	-	-
1989	5601	(4)	M/L. Uruk	2.4.3.4	3G 81c	-	Ci	-	-	-	-
1990	5611	M/L. Uruk	2.4.3.4	3G 81a	-	Ci	-	-	-	-	-
1991	5941	L. Uruk?	2.4.3.4	3G 61	-	Ci	-	-	-	-	*
1992	5601	M/L. Uruk	2.4.3.5	3G 81c	-	Bi	-	-	-	-	-
1993	5611	(4)	M/L. Uruk	2.4.3.5	3G 81a	-	Bi	-	-	-	-
1994	5408	ED I	2.4.3.6	2G 36b	-	Liv	448	-	4/12	-	*
1995	5550	Uruk	2.4.3.6	2G 46d	-	Aii	482	-	5/5	-	*
1996	5601	M/L. Uruk	2.4.3.6	3G 81c	-	Ii	-	-	-	-	-
1997	5611	M/L. Uruk	2.4.3.6	3G 81a	-	Bii	-	-	-	-	-
1998	5923	Uruk?	2.4.3.6	3G 72	McAdam 1983, 75, fig.203 no.124	Bi	-	-	-	-	*
1999	5941	L. Uruk?	2.4.3.6	3G 61	-	Aiv	-	-	-	-	-
2000	5212	ED III	2.4.3.7	6F 25 (Area E)	-	Bii	-	-	-	-	-

1	2	3	4	5	6	7	8	9	10	11	12
2001	5423	ED I	2.4.3.7	2G 36d	-	Biii	-	-	-	-	-
2002	5601	M/L. Uruk	2.4.3.7	3G 81c	-	Hii	535	-	5/19	54/12	-
2.4.4 Jar sherds: rolled rims											
2003	5551	Uruk	2.4.4.1	2G 46d	-	Miv	492	-	2/5	-	-
2004	5944	L. Uruk?	2.4.4.1	3G 61	-	Aiv	-	-	-	-	-
2005	5547	Uruk	2.4.4.2	2G 46d	-	Bii	473	-	25/10	-	*
2006	5940	L. Uruk?	2.4.4.2 (waster)	3G 61	-	Hii	-	-	-	-	-
2007	5947	L. Uruk?	2.4.4.3	3G 61	-	Dii	-	-	-	-	-
2008	5611	M/L. Uruk	2.4.4.4	3G 81a	-	Biii	-	-	-	-	-
2.4.5 Jar sherds: bevelled rim											
2009	5212	ED III	2.4.5.1	6F 25 (Area E)	-	Aiv	-	-	-	-	-
2010	5408	ED I	2.4.5.1	2G 36b	-	Eiii	-	-	-	-	-
2011	5547	Uruk	2.4.5.1	2G 46d	-	Ei	-	-	-	-	*
2012	5551	Uruk	2.4.5.1	2G 46d	-	Gi	488	-	-	-	*
2013	5601	M/L. Uruk	2.4.5.1	3G 81c	-	Hiii	536	-	5/15	54/20	-
2014	5611	M/L. Uruk	2.4.5.1	3G 81a	-	Dii	-	-	-	-	-
2015	5942	L. Uruk?	2.4.5.1	3G 61	-	Eii	-	-	-	-	-
2016	5523	E. ED I	2.4.5.1 8.6.2	2G 46d	-	Aiii	-	-	-	-	-
2017	5544	Uruk	2.4.5.1 8.6.8	2G 46d	-	Gi	-	-	-	-	*
2018	5601	M/L. Uruk	2.4.5.2	3G 81c	-	Hi	553	-	3/16	54/7 54/8	*

1	2	3	4	5	6	7	8	9	10	11	12
2019	5611		M/L. Uruk	2.4.5.2	3G 81a	-	Hiii	-	-	-	-
2020	5611		M/L. Uruk	2.4.5.3	3G 81a	-	Gi	-	-	-	-
2021	5408		ED I	2.4.5.4	2G 36b	-	Aiv	440	-	3/8	*
2022	5408		ED I	2.4.5.4	2G 36b	-	Avii	-	-	-	-
2023	5212	(2)	ED III	2.4.5.4	6F 25 (Area E)	-	Bi	-	-	-	-
2024	5411		ED I	2.4.5.4	2G 36d	-	Bii	472	-	25/8	54/36 -
2025	5413		ED I	2.4.5.4	2G 36d	-	Ci	-	-	-	-
2026	5413		ED I	2.4.5.4	2G 36d	-	Bii	-	-	-	-
2027	5523		E. ED I	2.4.5.4	2G 46d	-	Aix	-	-	-	-
2028	5547		Uruk	2.4.5.4	2G 46d	-	Biii	-	-	-	-
2029	5601	(6)	M/L. Uruk	2.4.5.4	3G 81c	-	Hiv	-	-	-	-
2030	5601	(3)	M/L. Uruk	2.4.5.4	3G 81c	-	Hvii	-	-	-	-
2031	5602		M/L. Uruk	2.4.5.4	3G 81c	-	Ci	-	-	-	-
2032	5611		M/L. Uruk	2.4.5.4	3G 81a	-	Cii	-	-	-	-
2033	5611		M/L. Uruk	2.4.5.4	3G 81a	-	Hii	-	-	-	-
2034	5905		Uruk?	2.4.5.4	3G 80	McAdam 1983, 61, fig.66 no.32	Bii	-	-	-	-
2035	5408		ED I	2.4.5.4.1	2G 36b	-	Aiv	-	-	-	-
2036	5601		M/L. Uruk	2.4.5.4.1	3G 81c	-	Dii	-	-	-	-
2037	5029		ED I?	2.4.5.5	2G 31	-	Bi	-	-	-	-
2038	5408		ED I	2.4.5.5	2G 36b	-	Aiv	-	-	-	*
2039	5553		Uruk	2.4.5.5	2G 46d	-	Hiv	-	-	1/34	*

1	2	3	4	5	6	7	8	9	10	11	12
2040	5601	M/L. Uruk	2.4.5.5	3G 81c	-	Hiv	542	-	2/17	54/22	-
2041	5408	ED I	2.4.5.6	2G 36b	-	Bi	-	-	-	-	*
2042	5408	ED I	2.4.5.6	2G 36b	-	Av	447	-	3/10	-	*
2043	5601	M/L. Uruk	2.4.5.6	3G 81c	-	Bi	-	-	-	-	-
2044	5913	Uruk?	2.4.5.6	3G 70	McAdam 1983, 61, fig.66 no.32	Hii	-	-	-	-	-
2045	5411	ED I	2.4.5.7	2G 36d	-	Ciii	470	-	25/4	-	*
2046	5412	(3)	ED I	2.4.5.7	2G 36d	Pii	-	-	-	-	-
2047	5408	ED I	2.4.5.7 8.6.2	2G 36b	-	Bi	435	-	3/7	-	*
2.4.6 Jar sherds: collar/band rim											
2048	5900	Uruk?	2.4.6.1	3G 90	McAdam 1983, 61, fig.67 no.33	Bvi	-	-	-	-	*
2049	5005	(2)	ED I?	2.4.6.3	2G 70	-	-	-	-	-	-
2050	5004	ED I?	2.4.6.4	2G 80	-	-	-	-	-	-	-
2051	5551	Uruk	2.4.6.4	2G 46d	-	Ki?	-	-	-	-	-
2052	5551	Uruk	2.4.6.4	2G 46d	-	Hix	-	-	-	-	-
2053	5601	M/L. Uruk	2.4.6.4	3G 81c	-	Di	526	-	3/20	54/9	*
2054	5416	ED I	2.4.6.5	2G 36b	-	Hii	-	-	-	-	*
2055	5550	Uruk	2.4.6.5	2G 46d	-	Aii	481	-	5/7	-	-
2056	5553	Uruk	2.4.6.5	2G 46d	-	Aix	-	-	-	-	-
2057	5601	M/L. Uruk	2.4.6.5	3G 81c	-	Bi	509	-	1/24	-	*
2058	5601	M/L. Uruk	2.4.6.5	3G 81c	-	Bi	-	-	-	-	-
2059	5941	L. Uruk?	2.4.6.5	3G 61	-	Hiv	-	-	-	-	-

1	2	3	4	5	6	7	8	9	10	11	12
2060	5601		M/L. Uruk	2.4.6.6	3G 81c	-	Dii	-	-	-	-
2061	5602		M/L. Uruk	2.4.6.6	3G 81c	-	Aix	-	-	-	-
2062	5916		Uruk?	2.4.6.6	3G 50	McAdam 1983, 61, fig.69 no.35	Bii	-	-	-	-
2063	5601		M/L. Uruk	2.4.6.7	3G 81c	-	Biii	527	-	1/14	*
2064	5423		ED I	2.4.6.8	2G 36d	-	Bii	-	-	-	-
2.4.7 Jar sherds: collar/band rim; dished/grooved											
2065	5005	(2)	ED I?	2.4.7.1	2G 70	-	Bii	-	-	-	-
2066	5212	(2)	ED III	2.4.7.1	6F 25 (Area E)	-	Bi	-	-	-	-
2067	5408		ED I	2.4.7.2	2G 36b	-	Bi	-	-	-	-
2068	5523		E. ED I	2.4.7.2	2G 46d	-	Ci	-	-	-	-
2069	5601		M/L. Uruk	2.4.7.2	3G 81c	-	Ci	-	-	-	-
2070	5031		ED I?	2.4.7.3	2G 11	-	Bii	-	-	-	-
2071	5034		ED I?	2.4.7.3	2G 11	-	Bi	-	-	-	-
2072	5408		ED I	2.4.7.4	2G 36b	-	Bi	-	-	-	*
2073	5422		ED I	2.4.7.4	2G 36b	-	Aiii	-	-	-	-
2074	5601		M/L. Uruk	2.4.7.4	3G 81c	-	Hxii	-	-	-	-
2075	5943		L. Uruk?	2.4.7.4	3G 61	-	Hxii	-	-	-	-
2.4.8 Jar sherds: flat rim											
2076	5034		ED I?	2.4.8.1	2G 11	-	-	-	-	-	-
2077	5547		Uruk	2.4.8.1	2G 46d	-	Aix	-	-	-	-
2078	5029		ED I?	2.4.8.2	2G 31	-	-	-	-	-	-

1	2	3	4	5	6	7	8	9	10	11	12
2079	5550	(2)	Uruk	2.4.8.2	2G 46d	-	Ii	-	-	-	-
2080	5601		M/L. Uruk	2.4.8.2	3G 81c	-	Ci	500	-	1/26	*
2081	5601	(2)	M/L. Uruk	2.4.8.2	3G 81c	-	Aix	-	-	-	-
2082	5601		M/L. Uruk	2.4.8.2	3G 81c	-	Ji	-	-	-	*
2083	5939		L. Uruk?	2.4.8.2	3G 60	-	Ci	-	-	-	-
2084	5946		L. Uruk?	2.4.8.2	3G 61	-	Mii	-	-	-	-
2085	5924		Uruk?	2.4.8.3	2G 82	-	Biii	-	-	-	*
2086	5408		ED I	2.4.8.4	2G 36b	-	Cii	436	-	3/11	*
2087	5411		ED I	2.4.8.5	2G 36d	-	Aiv	-	-	-	-
2088	5601		M/L. Uruk	2.4.8.5	3G 81c	-	Ei	512	-	1/17 1/18	*
2089	5601	(10)	M/L. Uruk	2.4.8.5	3G 81c	-	Aiv	-	-	-	-
2090	5602		M/L. Uruk	2.4.8.5	3G 81c	-	Ei	-	-	-	-
2091	5948		L. Uruk?	2.4.8.5	3G 61	-	Aiv	-	-	-	-
2092	5601		M/L. Uruk	2.4.8.5 8.17 13.1.1	3G 81c	-	Di	-	-	-	-
2093	5411		ED I	2.4.8.6	2G 36d	-	Bv	468	-	24/35	54/34
2094	5523		E. ED I	2.4.8.6	2G 46d	-	Hi	-	-	-	-
2095	5601		M/L. Uruk	2.4.8.7	3G 81c	-	Ci	-	-	-	-
2096	5601	(2)	M/L. Uruk	2.4.8.7	3G 81c	-	Bi	-	-	-	-
2097	5611		M/L. Uruk	2.4.8.7	3G 81a	-	Bi	-	-	-	-
2098	5601		M/L. Uruk	2.4.8.7 8.17 13.1.1	3G 81c	-	Di	-	-	-	-

1	2	3	4	5	6	7	8	9	10	11	12	
2099	5411	(2)	ED I	2.4.8.8	2G 36d	-	Aiv	-	-	-	-	
2100	5411		ED I	2.4.8.8	2G 36d	-	Avii	-	-	-	-	
2101	5412		ED I	2.4.8.8	2G 36d	-	Aiv	513	-	-	*	
2102	5412		ED I	2.4.8.8	2G 36d	-	Avii	-	-	-	*	
2103	5412	(2)	ED I	2.4.8.8	2G 36d	-	Eiii	-	-	-	-	
2104	5416	(2)	ED I	2.4.8.8	2G 36b	-	Avii	-	-	-	*	
2105	5422	(6)	ED I	2.4.8.8	2G 36b	-	Avii	-	-	-	-	
2106	5423		ED I	2.4.8.8	2G 36d	-	Cii	-	-	-	-	
2107	5408		ED I	2.4.8.8 8.8.1	2G 36b	-	Aiv	-	-	-	-	
2108	5408		ED I	2.4.8.8 8.8.1	2G 36b	-	Avii	438	-	3/14	-	*
2109	5408		ED I	2.4.8.8 8.8.1	2G 36b	-	Avii	437	-	3/13	-	*
2110	5413	(3)	ED I	2.4.8.8 8.9.2	2G 36d	-	Avii	-	-	-	-	
2111	5416		ED I	2.4.8.8 8.9.2	2G 36b	-	Avii	-	-	-	-	
2112	5905		Uruk?	2.4.8.8 8.9.4	3G 80	McAdam 1983, 65, fig.98 no.54; 64	Aiv	-	-	-	-	
2.4.9 Jar sherds: coarse ware rims												
2113	5601		M/L. Uruk	2.4.9	3G 81c	-	Mii	531	-	1/12	54/11	-
2114	5601		Uruk	2.4.9.1	2G 46d	-	Piii	-	-	1/15	-	*
2115	5550		Uruk	2.4.9.2	2G 46d	-	Qi	-	-	-	-	-
2116	5944		L. Uruk?	2.4.9.2	3G 61	-	Qii	-	-	-	-	-

1	2	3	4	5	6	7	8	9	10	11	12
2117	5601	M/L. Uruk	2.4.9.3	3G 81c	-	Qi	544	-	3/23	54/10	*
2118	5602	M/L. Uruk	2.4.9.3	3G 81c	-	Qiii	-	-	-	-	-
2119	5601	M/L. Uruk	2.4.9.3 13.2.1	3G 81c	-	Pi	523	-	1/11	-	-
2120	5551	Uruk	2.4.9.4	2G 46d	-	Qi	-	-	-	-	-
2121	5408	ED I	2.4.9.5	2G 36b	-	Gii	454	-	3/5	-	*
2.5 Jar rims: decorated											
2.5.1 Jar rim: cable decoration											
2122	5408	ED I	2.5.1	2G 36b	-	Eiii	-	-	-	-	-
2.5.2 Jar rim: notched decoration											
2123	5901	Uruk?	2.5.2	3G 90	McAdam 1983, 65, fig.97 no.53; 70	Aiii	-	-	-	-	-
3 Bottles											
2124	5948 : 3GS : 104	L. Uruk?	3	3G 61	-	Lii	-	-	-	-	-
3.1 Bottles: bevelled rim											
2125	5422	ED I	3.1	2G 36b	-	Mi	-	-	-	-	-
2126	5947	L. Uruk?	3.1	3G 61	-	Liii	-	-	-	-	-
2127	5901	Uruk?	3.1 2.4.2.8	3G 90	McAdam 1983, 61, fig.65 no.31	Aii	-	-	-	-	-
3.3 Bottles: long neck											
3.3.1 Bottles: long neck; bevelled rim											
2128	5601	M/L. Uruk	3.3.1	3G 81c	-	Cii	-	-	-	-	-
5 Spouted jars											
2129	5030 (5)	ED I?	5	2G 21	-	-	-	-	-	-	-

1	2	3	4	5	6	7	8	9	10	11	12
2130	5408		ED I	5 8.6.1 8.9.1	2G 36b	-	Avii	-	-	-	-
2131	5408	(6)	ED I	5 8.6.2	2G 36b	-	Avii	-	-	-	-
2132	5601	: 3G 81 : 241	M/L. Uruk	5 8.8.1	3G 81c	-	Hii?	-	-	-	-
2133	5004		ED I?	5 13.3.4	2G 80	-	Aiv	-	-	-	-
5.7 Spouted jar sherds: spouts											
2134	5005		ED I?	5.7	2G 70	-	Avi	-	-	-	-
2135	5029	(3)	ED I?	5.7	2G 31	-	-	-	-	-	-
2136	5408	(9)	ED I?	5.7	2G 36b	-	Aiv	-	-	-	-
2137	5423		ED I	5.7	2G 36d	-	Diii	-	-	-	-
2138	5553		Uruk	5.7	2G 46d	-	Aiv	-	-	-	-
2139	5601	(3)	M/L. Uruk	5.7	3G 81c	-	Avi	-	-	-	-
2140	5602	(3)	M/L. Uruk	5.7	3G 81c	-	Avi	-	-	-	-
2141	5611	(2)	M/L. Uruk	5.7	3G 81a	-	Ci	-	-	-	-
2142	5904		Uruk?	5.7	3G 80	McAdam 1983, 65, fig.100 no.57	Avi	-	-	-	-
2143	5601		M/L. Uruk	5.7 2.4.1.1	3G 81c	-	Mii	-	-	-	-
2144	5544		Uruk	5.7 2.4.3.6	2G 46d	-	Avi	-	-	-	-
5.7.1 Short spouts											
2145	5408		ED I	5.7.1	2G 36b	-	Aiv	-	-	-	-
2146	5602		M/L. Uruk	5.7.1	3G 81c	-	Hiii	-	-	-	-

1	2	3	4	5	6	7	8	9	10	11	12
2147	5411	ED I	5.7.1 8.20	2G 36d	-	Ciii	-	-	-	-	-
2148	5408	ED I	5.7.1.1	2G 36b	-	Avi	-	-	-	-	-
2149	5523	E. ED I	5.7.1.1	2G 46d	-	Ei	-	-	-	-	-
2150	5900	Uruk?	5.7.1.1	3G 90	c.f. McAdam 1983, 65, fig.101 no.58	Aiv	-	-	-	-	-
2151	5945	: 3GS : 03	L. Uruk?	5.7.1.1 2.4.1.3 8.6.1	3G 61	-	-	-	-	-	-
2152	5408	ED I	5.7.1.1 2.4.1.6 8.4.3	2G 36b	-	Avii	-	-	-	-	*
5.7.2 Long spouts											
2153	5093	ED I?	5.7.2	2G 55	McAdam 1983, 77, fig.216 no.138	Biii	-	-	-	-	-
2154	5103	ED I?	5.7.2	2G 65	McAdam 1983, 77, fig.217 no.139	Jiv	-	-	-	-	-
2155	5408	ED I	5.7.2	2G 36b	-	Avii	-	-	-	-	-
2156	5411	ED I	5.7.2	2G 36d	-	Ei	-	-	-	-	-
2157	5412	ED I	5.7.2	2G 36d	-	Avii	-	-	-	-	-
2158	5422	(2)	ED I	5.7.2	2G 36b	-	Avii	-	-	-	-
2159	5913	Uruk?	5.7.2	3G 70	McAdam 1983, 65, fig.108 no.62	Ci	-	-	-	-	-
5.7.3 Conical spouts											
2160	5408	ED I	5.7.3	2G 36b	-	Avi	-	-	-	-	-
2161	5601	M/L. Uruk	5.7.3	3G 81c	-	Bvi	-	-	-	-	-
2162	5927	Uruk?	5.7.3	3G 92	McAdam 1983, 65, fig.107 no.61	Bvi	-	-	-	-	-
2163	5408	ED I	5.7.3 2.4.2.2	2G 36b	-	Jii	-	-	-	-	-

1	2	3	4	5	6	7	8	9	10	11	12
2164	5117	ED I?	5.7.3 2.4.7.4	2G 26	McAdam 1983, 77, fig.214 no.136	Bvi	-	-	-	-	-
5.7.5 Downswept/drooping spouts											
2165	5909	Uruk?	5.7.5	3G 60	McAdam 1983, 65, fig.105 no.60	Bii	-	-	-	-	-
2166	5934	Uruk?	5.7.5	3G 93	McAdam 1983, 65, fig.105 no.60	Biii	-	-	-	-	-
5.7.6 Spouts attached to rim											
2167	5093	ED I?	5.7.6 13.2.2	2G 55	McAdam 1983, 77, fig.218 no.140; 141; 146	Bvi	-	-	-	-	-
8 <u>Body sherds (jars)</u>											
8.3 Combed decoration											
2168	5004	(2)	ED I?	8.3	2G 80	-	-	-	-	-	-
8.3.1 Combed decoration: horizontal lines											
2169	5553		Uruk	8.3.1	2G 46d	-	Hiv	-	-	-	-
2170	5600	(4)	M/L. Uruk	8.3.1	3G 81a11	-	Hvii	-	-	-	-
2171	5600		M/L. Uruk	8.3.1	3G 81a11	-	Hix	557	-	-	-
2172	5601	(2)	M/L. Uruk	8.3.1	3G 81c	-	Hxi	550	-	2/27	54/15
2173	5601	(9)	M/L. Uruk	8.3.1	3G 81c	-	Hiii	-	-	-	-
2174	5602		M/L. Uruk	8.3.1	3G 81c	-	Ji	-	-	-	-
2175	5937		L. Uruk?	8.3.1	3G 60	-	Hvi	-	-	-	-
2176	5937		L. Uruk?	8.3.1	3G 60	-	Jii	-	-	-	-
2177	5941		L. Uruk?	8.3.1 (waster)	3G 61	-	-	-	-	-	-
2178	5946		L. Uruk?	8.3.1	3G 61	-	Jii	-	-	-	-

1	2	3	4	5	6	7	8	9	10	11	12	
2179	5948	(3)	L. Uruk?	8.3.1	3G 61	-	Hxii	-	-	-	-	
2180	5601		M/L. Uruk	8.3.1 2.1	3G 81c	-	Bii	528	-	5/31	54/24	-
2181	5602		M/L. Uruk	8.3.1 8.6.3	3G 81c	-	Ji	533	-	2/8	-	*
2182	5603		M/L. Uruk	8.3.1 8.6.8	3G 81c	-	Bii	529	-	5/28	-	*
8.3.2 Combed decoration: diagonal lines												
2183	5601		M/L. Uruk	8.3.2	3G 81c	-	Jii	532	-	2/12	-	*
8.3.3 Combed decoration: 'wickerwork'												
2184	5069		ED I?	8.3.3	2G 73	McAdam 1983, 77, fig.239 no.148	Hiv	-	-	-	-	-
2185	5523		E. ED I	8.3.3	2G 46d	-	Hiv	-	-	-	-	*
2186	5523	(6)	E. ED I	8.3.3	2G 46d	-	Hv	-	-	-	-	-
2187	5550		Uruk	8.3.3	2G 46d	-	Hix	490	-	5/9	-	*
2188	5550		Uruk	8.3.3 (waster)	2G 46d	-	Hix?	491	-	5/12	-	*
2189	5550		Uruk	8.3.3	2G 46d	-	Hix	-	-	-	-	-
2190	5551	(4)	Uruk	8.3.3	2G 46d	-	Hx	-	-	-	-	-
2191	5601		M/L. Uruk	8.3.3	3G 81c	-	Hiii	539	-	5/34	-	*
2192	5611	(5)	M/L. Uruk	8.3.3	3G 81a	-	Hv	-	-	-	-	-
8.3.4 Combed decoration: horizontal-cross-vertical												
2193	5553		Uruk	8.3.4	2G 46d	-	Hiii	-	-	-	-	-
8.3.5 Combed decoration: diagonal-cross-vertical												
2194	5601		M/L. Uruk	8.3.5	3G 81c	-	Hiii	538	-	2/9	-	*

1	2	3	4	5	6	7	8	9	10	11	12
8.4 Lugged jar sherds											
2195	5413	ED I	8.4 8.5.5	2G 36d	-	Piii	-	-	-	-	-
2196	5601	M/L. Uruk	8.4 13.1.3	3G 81c	-	Biii	-	-	-	-	-
8.4.1 Lugged jar sherds: lug perforated											
2197	5422	ED I	8.4.1.1	2G 36b	-	Aiv	-	-	-	-	-
2198	5523	E. ED I	8.4.1.1	2G 46d	-	Ci	-	-	-	-	-
2199	5551	Uruk	8.4.1.1	2G 46d	-	Eii	-	-	-	-	-
2200	5601	M/L. Uruk	8.4.1.1	3G 81c	-	Fi	-	-	-	-	-
8.4.2 Lugged jar sherds: plain lug											
2201	5947	L. Uruk?	8.4.2.1 8.6.8	3G 61	-	Bi	-	-	-	-	-
2202	5935	Uruk?	8.4.2.1 13.2.4 13.2.9	3G 93	McAdam 1983, 65, fig.99 no.55; 66	Biii	-	-	-	-	-
2203	5408	ED I	8.4.2.2 8.12	2G 36b	-	Ei	-	-	-	-	-
8.5 Incised decoration											
8.5 Incised decoration: cross-hatched											
2204	5422	ED I	8.5.2	2G 36b	-	Aiv	-	-	-	-	-
2205	5523	E. ED I	8.5.2	2G 46d	-	Bii	-	-	-	-	-
2206	5601	(2)	M/L. Uruk	8.5.2	3G 81c	-	Ci	-	-	-	-
2207	5601	(2)	M/L. Uruk	8.5.2	3G 81c	-	Dii	-	-	-	-
2208	5601	M/L. Uruk	8.5.2	3G 81c	-	Hv	-	-	-	-	-

1	2	3	4	5	6	7	8	9	10	11	12
2209	5602		M/L. Uruk	8.5.2	3G 81c	-	Ci	-	-	-	-
2210	5611		M/L. Uruk	8.5.2	3G 81a	-	Ci	-	-	-	-
2211	5408	(12)	ED I	8.5.2 8.12.1	2G 36b	-	Aiv	-	-	-	-
2212	5422		ED I	8.5.2 8.13.1	2G 36b	-	Ci	-	-	-	-
8.5.4 Incised decoration: herringbone											
2213	5408		ED I	8.5.4	2G 36b	-	Avii	-	-	-	-
2214	5411		ED I	8.5.4 8.6.2.1	2G 36d	-	Aiv	-	-	-	-
8.5.6 Incised decoration: vertical lines											
2215	5943		L. Uruk?	8.5.6	3G 61	-	Eiii	-	-	-	-
8.5.7 Incised decoration: cross-hatched triangles											
2216	5408		ED I	8.5.7	2G 36b	-	Avii	-	-	-	-
8.6 Impressed decoration											
8.6.1 Impressed decoration: horizontal row of triangular nicks											
2217	5020		ED I?	8.6.1	2G 00	McAdam 1983, 79, fig.246 no.149	Avi	-	-	-	-
2218	5029		ED I?	8.6.1	2G 31	-	-	-	-	-	-
2219	5030		ED I?	8.6.1	2G 21	-	-	-	-	-	-
2220	5411		ED I	8.6.1	2G 36d	-	Bii	-	-	-	-
2221	5411	(2)	ED I	8.6.1	2G 36d	-	Aii	-	-	-	-
2222	5422		ED I	8.6.1	2G 36b	-	Aiv	-	-	-	-
2223	5601		M/L. Uruk	8.6.1	3G 81c	-	Ei	-	-	-	-

1	2	3	4	5	6	7	8	9	10	11	12
2224	5611		M/L. Uruk	8.6.1	3G 81c	-	Hiii	-	-	-	-
2225	5906		Uruk?	8.6.1	3G 81	McAdam 1983, 65, fig.125 no.72 pl.ivb	Bi	-	-	-	-
8.6.2 Impressed decoration: finger nail nicks (pricked)											
2226	5412	(2)	ED I	8.6.2	2G 36d	-	Hiii	-	-	-	-
2227	5913		Uruk?	8.6.2	3G 70	McAdam 1983, 65, fig.115 no.70	Hiii	-	-	-	-
2228	5423		ED I	8.6.2.1	2G 36d	-	Bii	-	-	-	-
2229	5909		Uruk?	8.6.2.1	3G 60	McAdam 1983, 65, fig.124 no.72	Hii	-	-	-	-
2230	5920		Uruk?	8.6.2.1	3G 62	McAdam 1983, 65, fig.117 no.70 pl.ivb	Bi	-	-	-	-
2231	5946		L. Uruk?	8.6.2.1	3G 61	-	Bi	-	-	-	-
8.6.4 Impressed decoration: zig-zag, rocker pattern											
2232	5601		M/L. Uruk	8.6.4	3G 81c	-	Jiii	-	-	-	-
2233	5921		Uruk?	8.6.4	3G 62	McAdam 1983, 67, fig.128 no.72	Hii	-	-	-	-
8.6.7 Impressed decoration: horizontal row of lozenge shapes											
2234	5413		ED I	8.6.7	2G 36d	-	Hiii	-	-	-	-
8.6.8 Cable impressed decoration: horizontal											
2235	5601		M/L. Uruk	8.6.8	3G 81c	-	Jiii	525	-	2/7	-
2236	5602		M/L. Uruk	8.6.8	3G 81c	-	Ji	475	-	25/18	*
2237	5601		M/L. Uruk	8.6.8 8.17.1	3G 81c	-	Bi	-	-	-	-
8.6.9 Impressed decoration: herringbone (see also 8.10)											
2238	5408	(4)	ED I	8.6.9	2G 36b	-	Biii	-	-	-	-

1	2	3	4	5	6	7	8	9	10	11	12
2239	5060	ED I	8.6.9 8.17.5 8.20	2G 23	McAdam 1983, 79, fig.253 no.149; 153	Aiv	-	-	-	-	-
8.7.2 Cut ware with incised cross-hatched decoration											
2240	5423	ED I	8.7.2	2G 36d	-	Aiv	-	-	-	-	-
2241	5913	Uruk?	8.7.2 8.6.2	3G 70	McAdam 1983, 65, fig.113 no.68; 70	Ci	-	-	-	-	-
8.8 Striated/grooved decoration (Tab-rim jars)											
8.8.1 Horizontal striated/grooved decoration											
2242	5408	(43)	ED I	8.8.1	2G 36b	-	Avii	-	-	-	-
2243	5416	(2)	ED I	8.8.1	2G 36b	-	Avii	-	-	-	-
2244	5408		ED I	8.8.1 8.20	2G 36b	-	Avii	444	-	4/9	-
8.8.2 Vertical striated/grooved decoration											
2245	5098		ED I?	8.8.2	2G 35	McAdam 1983, 77, fig.229 no.145	Avii	-	-	-	-
2246	5600		M/L. Uruk	8.8.2	3G 81all	-	Hvii	-	-	-	-
2247	5540		Uruk	8.8.2 8.5.6	2G 46d	-	Hvii	-	-	-	-
8.8.3 Horizontal-cross-vertical grooved decoration											
2248	5408	(9)	ED I	8.8.3	2G 36b	-	Fi	-	-	-	-
8.9 Reserve-slipped decoration											
2249	5005		ED I?	8.9	2G 70	-	Aiv	429	-	-	-
2250	5005		ED I?	8.9	2G 70	-	Bi	-	-	-	-
2251	5912		Uruk?	8.9	3G 70	McAdam 1983, 64, no.64	Bi	-	-	-	-

1	2	3	4	5	6	7	8	9	10	11	12
8.9.1 Diagonal reserve slip											
2252	5408	(2)	ED I	8.9.1	2G 36b	-	Aiv	-	-	-	-
2253	5411	(2)	ED I	8.9.1	2G 36d	-	Bi	-	-	-	-
2254	5551		Uruk	8.9.1	2G 46d	-	Avii	-	-	-	-
2255	5601	(4)	M/L. Uruk	8.9.1	3G 81c	-	Aix	-	-	-	-
2256	5611		M/L. Uruk	8.9.1	3G 81a	-	Ci	-	-	-	-
2257	5051		ED I?	8.9.1	2G 12	McAdam 1983, 77, fig.225 no.143; 149	Aiv	-	-	-	-
2258	5412	(5)	ED I	8.9.1 8.6.2	2G 36d	-	Aiv	-	-	-	-
2259	5416		ED I	8.9.1 8.6.7	2G 36b	-	Avii	-	-	-	-
8.9.2 Horizontal reserve slip											
2260	5408	(49)	ED I	8.9.2 8.6.2	2G 36b	-	Avii	-	-	-	-
2261	5408	(2)	ED I	8.9.2	2G 36b	-	Aiv	-	-	-	-
2262	5411	(2)	ED I	8.9.2	2G 36d	-	Ei	-	-	-	-
2263	5412	(8)	ED I	8.9.2	2G 36d	-	Ax	-	-	-	-
2264	5413	(7)	ED I	8.9.2	2G 36d	-	Ax	-	-	-	-
2265	5423	(5)	ED I	8.9.2	2G 36d	-	Avii	-	-	-	-
2266	5547		Uruk	8.9.2	2G 46d	-	Avii	-	-	-	-
2267	5601	(2)	M/L. Uruk	8.9.2	3G 81c	-	Ei	-	-	-	-
2268	5602		M/L. Uruk	8.9.2	3G 81c	-	Cii	-	-	-	-
2269	5413	(2)	ED I	8.9.2 8.6.1	2G 36d	-	Ci	-	-	-	-

1	2	3	4	5	6	7	8	9	10	11	12
2270	5422		ED I	8.9.2 8.6.1	2G 36b	-	Ax	-	-	-	-
2271	5085		ED I?	8.9.2 8.6.2	2G 14	McAdam 1983, 77, fig.222-224	Avi	-	-	-	-
2272	5408		ED I	8.9.2 8.6.2	2G 36b	-	Avii	-	-	-	-
8.9.4 Diagonal-cross-horizontal reserve slip											
2273	5412		ED I	8.9.4 8.6.2	2G 36d	-	Ax	-	-	-	*
2274	5412	(4)	ED I	8.9.4	2G 36d	-	Ax	-	-	-	-
2275	5413	(4)	ED I	8.9.4	2G 36d	-	Ax	-	-	-	-
2276	5416		ED I	8.9.4	2G 36b	-	Avii	-	-	-	-
2277	5422		ED I	8.9.4	2G 36b	-	-	-	-	-	-
8.9.5 Vertical reserve slip (see also 8.8.2)											
2278	5411		ED I	8.9.5	2G 36d	-	Ax	-	-	-	-
2279	5550		Uruk	8.9.5	2G 46d	-	Ei	484	-	1/33	-
2280	5601		M/L. Uruk	8.9.5	3G 81c	-	Cii	-	-	-	-
2281	5611	(2)	M/L. Uruk	8.9.5	3G 81a	-	Hii	-	-	-	-
2282	5611		M/L. Uruk	8.9.5	3G 81a	-	Ci	-	-	-	-
8.10 Leaf motif (herringbone pattern, see also 8.6.9)											
2283	5117		ED I?	8.10	2G 26	-	Avii	-	-	-	*
2284	5412		ED I	8.10	2G 36d	-	Biii	-	-	-	*
2285	5422		ED I	8.10	2G 36b	-	Biii	-	-	-	-
2286	5422		ED I	8.10 13.3.4	2G 36b	-	Biii	-	-	-	-

1	2	3	4	5	6	7	8	9	10	11	12
8.11 Plain ribs											
8.11.1 Single plain rib on shoulder carination											
2287	5029		ED I?	8.11.1	2G 31	-	Bi	-	-	-	-
2288	5601	(2)	M/L. Uruk	8.11.1	3G 81c	-	Dii	-	-	-	-
8.12 Decorated ribs: notched/nicked											
2289	5408	(19)	ED I	8.12	2G 36b	-	Ei	-	-	-	-
2290	5408	(7)	ED I	8.12	2G 36b	-	Eiii	-	-	-	-
8.12.1 Single rib with notched/nicked decoration											
2291	5411		ED I	8.12.1	2G 36d	-	Bv	-	-	-	-
2292	5412		ED I	8.12.1	2G 36d	-	Aiv	-	-	-	-
2293	5413	(3)	ED I	8.12.1	2G 36d	-	Cii	-	-	-	-
2294	5422		ED I	8.12.1	2G 36b	-	Ci	-	-	-	-
2295	5601	(2)	M/L. Uruk	8.12.1	3G 81c	-	Bi	450	-	-	-
8.12.2 Several ribs with notched/nicked decoration											
2296	5408		ED I	8.12.2	2G 36b	-	Avii	-	-	-	-
8.13 Decorated ribs: cable/piecrust											
8.13.1 Narrow cable rib (fine wares)											
2297	5411	(2)	ED I	8.13.1	2G 36d	-	Aiii	-	-	-	-
2298	5412	(4)	ED I	8.13.1	2G 36d	-	Bi	-	-	-	-
2299	5423	(2)	ED I	8.13.1	2G 36d	-	Ei	-	-	-	-
2300	5601		M/L. Uruk	8.13.1	3G 81c	-	Ji	-	-	-	-

1	2	3	4	5	6	7	8	9	10	11	12	
2301	5602		M/L. Uruk	8.13.1	3G 81c	-	Hix	556	-	1/38	-	-
8.13.2 Wide cable rib												
2302	5212	(5)	ED III	8.13.2	6F 25 (Area E)	-	Bii	-	-	-	-	-
2303	5408	(15)	ED I	8.13.2	2G 36b	-	Ei	-	-	-	-	-
2304	5412		ED I	8.13.2	2G 36d	-	Jii	-	-	-	-	-
2305	5601		M/L. Uruk	8.13.2	3G 81c	-	Mii	-	-	-	-	-
2306	5948		L. Uruk?	8.13.2	3G 61	-	Hviii	-	-	-	-	-
8.13.3 Cable rib: twisted/corded decoration												
2307	5413		ED I	8.13.3	2G 36d	-	Bii	-	-	-	-	-
8.13.4 Cable rib: vestigial												
2308	5028		ED I?	8.13.4	2G 41	-	Biii	-	-	-	-	-
2309	5600		M/L. Uruk	8.13.4	3G 81a11	-	Hvii	494	-	-	54/2 54/3	-
2310	5935		Uruk?	8.13.4	3G 93	McAdam 1983, 65, fig.122 no.71	Avii	-	-	-	-	-
8.13.5 Several cable ribs: vestigial												
2311	5602		M/L. Uruk	8.13.5	3G 81c	-	Hiv	-	-	-	-	-
8.16 Decorated coarse ware (Large jars)												
2312	5029	(9)	ED I?	8.16	2G 31	-	Qi?	-	-	-	-	-
2313	5031	(3)	ED I?	8.16	2G 11	-	Qi?	-	-	-	-	-
2314	5413	(2)	ED I	8.16	2G 36d	-	Qii	-	-	-	-	-
8.16.1 Coarse ware: single plain rib												
2315	5030	(4)	ED I?	8.16.1	2G 21	-	Qii?	-	-	-	-	-

1	2	3	4	5	6	7	8	9	10	11	12
2316	5212		ED III	8.16.1	6F 25 (Area E)	-	Qii	-	-	-	-
2317	5030	(2)	ED I?	8.16.1	2G 36b	-	Qiv	-	-	-	-
8.16.2 Coarse ware: single cable rib											
2318	5212		ED III	8.16.2	6F 25 (Area E)	-	Qiii	-	-	-	-
2319	5408	(2)	ED I	8.16.2	2G 36b	-	Qii	-	-	-	-
2320	5059		ED I?	8.16.2 8.16.2.1	2G 33	McAdam 1983, 79, fig.257 no.150 Postgate 1983, pl.6a	Qi	-	-	-	-
2321	5411		ED I	8.16.2.1	2G 36d	-	Qi	-	-	-	-
8.16.5 Coarse ware with perforated lug											
2322	5550		Uruk	8.16.5	2G 46d	-	Qi	-	-	-	-
8.17 Burnished											
2323	5523		E. ED I	8.17	2G 46d	-	Dii	-	-	-	-
8.17.1 Grey burnished											
2324	5602		M/L. Uruk	8.17.1	3G 81c	-	Hii	-	-	-	-
2325	5602		M/L. Uruk	8.17.1	3G 81c	-	Hvii	-	-	-	-
2326	5602		M/L. Uruk	8.17.1	3G 81c	-	Hxi	-	-	-	-
8.17.2 Pink burnished											
2327	5408	(6)	ED I	8.17.2	2G 36b	-	Avi	-	-	-	-
2328	5408		ED I	8.17.2	2G 36b	-	Ax	-	-	-	-
2329	5553		Uruk	8.17.2	2G 46d	-	Aix	-	-	-	-
2330	5611	(2)	M/L. Uruk	8.17.2	3G 81a	-	Aix	-	-	-	-

1	2	3	4	5	6	7	8	9	10	11	12
8.17.3 Red burnished											
2331	5602	M/L. Uruk	8.17.3	3G 81c	-	Aiv	-	-	-	-	-
8.17.6 Burnished inside vessel only											
2332	5422	ED I	8.17.6	2G 36b	-	Aiii	-	-	-	-	-
8.18 Handles											
8.18.1 Strap handles											
2333	5408	ED I	8.18.1	2G 36b	-	Bi	-	-	-	-	-
2334	5553	Uruk	8.18.1	2G 46d	-	Aix	-	-	-	-	-
2335	5601	M/L. Uruk	8.18.1	3G 81c	-	Hiii	540	-	6/2	-	-
2336	5601	(3) M/L. Uruk	8.18.1	3G 81c	-	Ji	-	-	-	-	-
2337	5601	M/L. Uruk	8.18.1	3G 81c	-	Hx	-	-	-	-	-
2338	5940	L. Uruk?	8.18.1 (waster)	3G 61	-	Hx	-	-	-	-	-
2339	5611	M/L. Uruk	8.18.1	3G 81a	-	Hx	-	-	-	-	-
2340	5600	: 3G 81 : 229	M/L. Uruk	8.18.1 2.1	3G 81all	Postgate and Moon 1982, 115, fig.5 no. 9	Hx	-	-	-	-
2341	5937	L. Uruk?	8.18.1 2.1	3G 60	-	-	-	-	-	-	-
2342	5910	Uruk?	8.18.1 8.6.2.1	3G 61	McAdam 1983, 65, fig.93 no.51; 70	Hx	-	-	-	-	-
2343	5922	Uruk?	8.18.1.1 (waster)	3G 72	McAdam 1983, 65, fig.96 no.52	Hii	-	-	-	-	-
2344	5929	Uruk?	8.18.1.2	3G 52	McAdam 1983, 65, fig.94 no.51; 65	Avi	-	-	-	-	-
8.19 Lipped											
2345	5910	Uruk?	8.19 8.4.1.1	3G 61	McAdam 1983, 67, fig.137 no.78	Bi	-	-	-	-	-

1	2	3	4	5	6	7	8	9	10	11	12
8.20 Carinated shoulder sherds											
2346	5423	ED I	8.20	2G 36d	-	Lii	-	-	-	-	-
2347	5932	Uruk?	8.20	3G 83	-	Ii	-	-	-	-	-
9. <u>Upright-handled jars</u>											
2348	5212 : 6F 25 : 24	ED III	9	6F 25 (Area E)	-	Aiii	-	-	-	-	-
2349	5004	ED I?	9? 8.18.3	2G 80	-	Bi	-	-	-	-	-
10 <u>Stemmed dishes</u>											
2350	5005	ED I?	10	2G 70	-	Bi	431	-	15/9	-	-
10.7 Stemmed dish rims											
10.7.2 Stemmed dish rims: notched rib											
2351	5212 (2)	ED III	10.7.2	6F 25 (Area E)	-	Avii	-	-	-	-	-
10.7.3 Stemmed dish rim: notched rib and 'wavy-line' decoration											
2352	5212 : 6F 25 : 21	ED III	10.7.3	6F 25 (Area E)	-	Ei	-	-	-	-	*
11 <u>Hollow stands</u>											
11.3 Hollow stand: ribbed											
2353	5408	ED I	11.3	2G 36b	-	Ei	-	-	-	-	*
11.5 Hollow stands: ribbed and incised											
2354	5027	ED I?	11.5	2G 51	McAdam 1983, 82, no.159	Aiv	-	-	-	-	-
2355	5028	ED I?	11.5	2G 41	McAdam 1983, 81, fig.269 no.159	Aiv	-	-	-	-	-
2356	5913	Uruk?	11.5 8.6.9	3G 70	McAdam 1983, 65, fig.123 no.71	Bi	-	-	-	-	-

1	2	3	4	5	6	7	8	9	10	11	12
11.6 Hollow stands: ribbed, incised and fenestrated											
2357	5030	ED I?	11.6	2G 21	McAdam 1983, 81, fig.268 no.159	Ai	-	-	-	-	-
11.8 Hollow stands: cut ware											
2358	5408	ED I	11.8	2G 36b	-	Eiii	-	-	-	-	*
11.9 Lipped stands											
2359	5212 : 6F 25 : 26	ED III	11.9	6F 25 (Area E)	-	Bii	-	-	-	-	*
12 <u>Miniatures</u>											
12.1 Miniatures: bowl/goblet											
2360	5422	ED I	12.1	2G 36b	-	Aiii	-	-	-	-	-
2361	5601	M/L. Uruk	12.1 BRB	3G 81c	-	Ci	-	-	-	-	-
12.3 Miniatures: 'bag-pot' or 'thumb-pot'											
2362	5601	M/L. Uruk	12.3	3G 81c	-	Biii	-	-	-	-	-
12.6 Miniatures: sherds											
2363	5946	L. Uruk?	12.6 2.4.1.2 8.8.1	3G 61	-	Ei	-	-	-	-	-
2364	5943	L. Uruk?	12.6 8.18.1 8.6.2.1	3G 61	-	Bi	-	-	-	-	-
2365	5948	L. Uruk?	12.6 8.18.1 8.6.9	3G 61	-	Bii	-	-	-	-	-
2366	5601	M/L. Uruk	12.6 14.1.1	3G 81c	-	Aii	-	-	-	-	-

1	2	3	4	5	6	7	8	9	10	11	12
13	<u>Painted ware (Body sherds)</u>										
13.1	Painted ware: monochrome										
13.1.1	Monochrome: red-scarlet										
2367	5523	(2)	E. ED I	13.1.1	2G 46d	-	Ei	-	-	-	-
2368	5544		Uruk	13.1.1	2G 46d	-	Ci	-	-	-	-
2369	5547		Uruk	13.1.1	2G 46d	-	Ci	-	-	-	-
2370	5551		Uruk	13.1.1	2G 46d	-	Ci	-	-	-	-
2371	5601		M/L. Uruk	13.1.1	3G 81c	-	Fi	-	-	-	-
2372	5601	(9)	M/L. Uruk	13.1.1	3G 81c	-	Eiii	-	-	-	-
2373	5602		M/L. Uruk	13.1.1	3G 81c	-	Ci	-	-	-	-
2374	5611		M/L. Uruk	13.1.1	3G 81a	-	Aiv	-	-	-	-
13.1.2	Monochrome: black										
2375	5408	(2)	ED I	13.1.2	2G 36b	-	Ei	-	-	-	-
2376	5600		M/L. Uruk	13.1.2	3G 81all	-	Aii	-	-	-	-
13.1.3	Monochrome: purple-plum										
2377	5408	(6)	ED I	13.1.3	2G 36b	-	Ei	-	-	-	-
2378	5408		ED I	13.1.3	2G 36b	-	Avii	443	-	4/11	-
2379	5411		ED I	13.1.3 13.3.1	2G 36d	-	Ciii	461	-	24/22	-
13.2	Painted ware: polychrome										
13.2.2	Polychrome: black on white slip										
2380	5601		M/L. Uruk	13.2.2	3G 81c	-	Aix	-	-	-	-

1	2	3	4	5	6	7	8	9	10	11	12
2381	5924		Uruk?	13.2.2	3G 82	McAdam 1983, 65, fig.110 no.66	Biii	-	-	-	-
2382	5601		M/L. Uruk	13.2.2 13.2.4	3G 81c	-	Aiii	-	-	-	-
13.2.4 Polychrome: purple on white slip											
2383	5600		M/L. Uruk	13.2.4	3G 81all	-	Aii	-	-	-	-
2384	5601	(5)	M/L. Uruk	13.2.4	3G 81c	-	Aiii	-	-	-	*
2385	5602		M/L. Uruk	13.2.4	3G 81c	-	Aix	-	-	-	-
2386	5098		ED I?	13.2.4 13.2.8	2G 35	-	Bi	-	-	-	-
13.2.7 Polychrome: purple cross-hatched on white slip											
2387	5601		M/L. Uruk	13.2.7	3G 81c	-	Aiv	-	-	-	-
14	<u>Bases</u>										
14.1 Flat bases											
14.1.1 Flat bases: string-cut (conical bowls)											
2388	5004	(21)	ED I?	14.1.1 1.1	2G 80	-	-	-	-	-	-
2389	5005	(4)	ED I?	14.1.1 1.1	2G 70	-	-	-	-	-	-
2390	5029	(9)	ED I?	14.1.1 1.1	2G 31	-	-	-	-	-	-
2391	5030		ED I?	14.1.1 1.1	2G 21	-	-	-	-	-	-
2392	5034		ED I?	14.1.1 1.1	2G 11	-	-	-	-	-	-
14.1.1 Flat bases: string-cut (conical bowls: base < 6.5cm)											
2393	5408	(40)	ED I	14.1.1 1.1	2G 36b	-	Aii	433	-	-	-

1	2	3	4	5	6	7	8	9	10	11	12
2394	5408	(51)	ED I	14.1.1 1.1	2G 36b	-	Aiv	-	-	-	-
2395	5408	(5)	ED I	14.1.1 1.1	2G 36b	-	Bi	450	-	2/36	-
2396	5408	(26)	ED I	14.1.1 1.1	2G 36b	-	Bii	-	-	-	-
2397	5411	(2)	ED I	14.1.1 1.1	2G 36d	-	Aiii	-	-	-	-
2398	5411	(7)	ED I	14.1.1 1.1	2G 36d	-	Aiv	-	-	-	-
2399	5411	(8)	ED I	14.1.1 1.1	2G 36d	-	Ciii	-	-	-	-
2400	5412	(4)	ED I	14.1.1 1.1	2G 36d	-	Aiii	-	-	-	-
2401	5412	(2)	ED I	14.1.1 1.1	2G 36d	-	Bix	-	-	-	-
2402	5412	(12)	ED I	14.1.1 1.1	2G 36d	-	Ei	-	-	-	-
2403	5413	(4)	ED I	14.1.1 1.1	2G 36d	-	Aiv	-	-	-	-
2404	5413	(8)	ED I	14.1.1 1.1	2G 36b	-	Ciii	-	-	-	-
2405	5416	(2)	ED I	14.1.1 1.1	2G 36b	-	Ciii	-	-	-	-
2406	5416	(3)	ED I	14.1.1 1.1	2G 36b	-	Ei	-	-	-	-
2407	5422	(4)	ED I	14.1.1 1.1	2G 36b	-	Bii	-	-	-	-
2408	5422	(3)	ED I	14.1.1 1.1	2G 36b	-	Ciii	-	-	-	-
2409	5423	(4)	ED I	14.1.1 1.1	2G 36d	-	Ciii	-	-	-	-

1	2	3	4	5	6	7	8	9	10	11	12
2410	5423	(3)	ED I	14.1.1 1.1	2G 36d	-	Eiii	-	-	-	-
2411	5423	(4)	E. ED I	14.1.1 1.1	2G 46d	-	Bix	-	-	-	-
2412	5547		Uruk	14.1.1 1.1	2G 46d	-	Bv	-	-	-	-
2413	5600	(4)	M/L. Uruk	14.1.1 1.1	3G 81all	-	Ni	-	-	-	-
2414	5601		M/L. Uruk	14.1.1 1.1	3G 81c	-	Aii	514	-	1/3	*
2415	5601	(15)	M/L. Uruk	14.1.1 1.1	3G 81c	-	Avi	-	-	-	-
2416	5601		M/L. Uruk	14.1.1 1.1	3G 81c	-	Ei	530	-	1/4	-
2417	5601	(9)	M/L. Uruk	14.1.1 1.1	3G 81c	-	Ei	-	-	-	-
2418	5601		M/L. Uruk	14.1.1 1.1	3G 81c	-	Hiii	-	-	-	-
14.1.1 Flat bases: string-cut (conical bowls > 6.5cm)											
2419	5408	(26)	ED I	14.1.1 1.1	2G 36b	-	Aiv	-	-	-	-
2420	5408	(13)	ED I	14.1.1 1.1	2G 36b	-	Bi	-	-	-	-
2421	5412	(2)	ED I	14.1.1 1.1	2G 36d	-	Aii	-	-	-	-
2422	5412		ED I	14.1.1 1.1	2G 36d	-	Aiv	-	-	-	-
2423	5422		ED I	14.1.1 1.1	2G 36d	-	Ei	-	-	-	-
2424	5423	(3)	ED I	14.1.1 1.1	2G 36d	-	Ei	-	-	-	-

1	2	3	4	5	6	7	8	9	10	11	12
Grosse blumentopf											
2425	5412		ED I	14.1.1 1.1	2G 36d	-	Aiv	-	-	-	-
14.1.1 Flat bases: string-cut (transitional bowls)											
2426	5601		M/L. Uruk	14.1.1 1.2	3G 81c	-	Cii	522	-	1/5	- *
2427	5601	(15)	M/L. Uruk	14.1.1 1.2	3G 81c	-	Avi	-	-	-	-
2428	5601	(17)	M/L. Uruk	14.1.1 1.2	3G 81c	-	Bix	-	-	-	-
2429	5601	(8)	M/L. Uruk	14.1.1 1.2	3G 81c	-	Cii	-	-	-	-
2430	5601	(3)	M/L. Uruk	14.1.1 1.2	3G 81c	-	Ei	-	-	-	-
2431	5601	(5)	M/L. Uruk	14.1.1 1.2	3G 81c	-	Niv	-	-	-	-
2432	5601	(2)	M/L. Uruk	14.1.1 1.2	3G 81c	-	Nv	-	-	-	-
14.1.1 Flat bases: string-cut (footed goblets)											
2433	5411	(9)	ED I	14.1.1 1.3.1	2G 36d	-	Aiii	-	-	-	-
2434	5411	(5)	ED I	14.1.1 1.3.1	2G 36d	-	Ei	-	-	-	-
2435	5412		ED I	14.1.1 1.3.1	2G 36d	-	Aiv	-	-	-	-
2436	5422	(5)	ED I	14.1.1 1.3.1	2G 36b	-	Ei	-	-	-	-
2437	5523	(5)	E. ED I	14.1.1 1.3.1	2G 46d	-	Ci	-	-	-	-
2438	5523	(2)	E. ED I	14.1.1 1.3.1	2G 46d	-	Cii	-	-	-	-

1	2	3	4	5	6	7	8	9	10	11	12
2439	5523	E. ED I	14.1.1 1.3.1	2G 46d	-	Ei	-	-	-	-	-
2440	5601	M/L. Uruk	14.1.1 1.3.1	3G 81c	-	Aii	-	-	-	-	-
14.1.1 Flat bases: string-cut (solid-footed goblets)											
2441	5005	ED I?	14.1.1 1.3.2	2G 70	-	Ei	430	-	15/12	-	-
2442	5029	ED I?	14.1.1 1.3.2	2G 31	-	-	-	-	-	-	-
2443	5034	ED I?	14.1.1 1.3.2	2G 11	-	-	-	-	-	-	-
2444	5408	ED I	14.1.1 1.3.2	2G 36b	-	Bii	457	-	2/32 6/15	-	-
2445	5408	(237)	ED I	14.1.1 1.3.2	2G 36b	-	Avii	-	-	-	-
2446	5408	ED I	14.1.1 1.3.2	2G 36b	-	Aiv	435	-	2/29 6/17	-	-
2447	5408	(264)	ED I	14.1.1 1.3.2	2G 36b	-	Biii	-	-	-	-
2448	5411	(2)	ED I	14.1.1 1.3.2	2G 36d	-	Ci	-	-	-	-
2449	5413	(11)	ED I	14.1.1 1.3.2	2G 36d	-	Aii	-	-	-	-
2450	5413	(7)	ED I	14.1.1 1.3.2	2G 36d	-	Aiv	-	-	-	-
2451	5413	(7)	ED I	14.1.1 1.3.2	2G 36d	-	Bi	-	-	-	-
2452	5413	(16)	ED I	14.1.1 1.3.2	2G 36d	-	Ci	-	-	-	-
2453	5413	(5)	ED I	14.1.1 1.3.2	2G 36d	-	Ei	-	-	-	-

1	2	3	4	5	6	7	8	9	10	11	12
2454	5413	(6)	ED I	14.1.1 1.3.2	2G 36d	-	Eiii	-	-	-	-
2455	5416		ED I	14.1.1 1.3.2	2G 36b	-	Aii	-	-	-	-
2456	5423	(3)	ED I	14.1.1 1.3.2	2G 36d	-	Aii	-	-	-	-
2457	5423		ED I	14.1.1 1.3.2	2G 36d	-	Aiv	-	-	-	*
2458	5423	(9)	ED I	14.1.1 1.3.2	2G 36d	-	Ci	-	-	-	-
2459	5523		E. ED I	14.1.1 1.3.2	2G 46d	-	Ci	-	-	-	-
Bevel-rim bowl bases (BRB)											
2460	5408		ED I	14 (BRB)	2G 36b	-	Ci	456	-	3/3	-
2461	5411	(2)	ED I	14 (BRB)	2G 36d	-	Bix	-	-	-	-
2462	5412		ED I	14 (BRB)	2G 36d	-	Bix	-	-	-	-
2463	5413		ED I	14 (BRB)	2G 36d	-	Bix	-	-	-	-
2464	5422		ED I	14 (BRB)	2G 36d	-	Bix	-	-	-	-
2465	5523	(5)	E. ED I	14 (BRB)	2G 46d	-	Ci	-	-	-	-
2466	5523		E. ED I	14 (BRB)	2G 46d	-	Niii	-	-	-	-
2467	5544	(5)	Uruk	14 (BRB)	2G 46d	-	Ni	-	-	-	-
2468	5544	(7)	Uruk	14 (BRB)	2G 46d	-	Niv	-	-	-	-
2469	5544	(3)	Uruk	14 (BRB)	2G 46d	-	Nvii	-	-	-	-
2470	5547	(4)	Uruk	14 (BRB)	2G 46d	-	Ni	-	-	-	-
2471	5550	(7)	Uruk	14 (BRB)	2G 46d	-	Gi	-	-	-	-

1	2	3	4	5	6	7	8	9	10	11	12
2472	5551	(9)	Uruk	14 (BRB)	2G 46d	-	Bix	-	-	-	-
2473	5551		Uruk	14 (BRB)	2G 46d	-	Niii	-	-	-	-
2474	5553	(9)	Uruk	14 (BRB)	2G 46d	-	Nii	-	-	-	-
2475	5551		Uruk	14 (BRB)	2G 46d	-	Nvi	-	-	-	-
2476	5600	(4)	M/L. Uruk	14 (BRB)	3G 81all	-	Ni	-	-	-	-
2477	5601		M/L. Uruk	14 (BRB)	3G 81c	-	Ci	502	-	1/1 1/2	-
2478	5601	(3)	M/L. Uruk	14 (BRB)	3G 81c	-	Gi	-	-	-	-
2479	5601	(7)	M/L. Uruk	14 (BRB)	3G 81c	-	Bix	-	-	-	-
2480	5601	(17)	M/L. Uruk	14 (BRB)	3G 81c	-	Ni	-	-	-	-
2481	5937	(5)	L. Uruk?	14 (BRB)	3G 60	-	Ni	-	-	-	-
2482	5937		L. Uruk?	14 (BRB)	3G 60	-	Niii	-	-	-	-
2483	5937	(17)	L. Uruk?	14 (BRB)	3G 60	-	Nvi	-	-	-	-
2484	5939	(2)	L. Uruk?	14 (BRB)	3G 60	-	Ni	-	-	-	-
2485	5939	(16)	L. Uruk?	14 (BRB)	3G 60	-	Nv	-	-	-	-
2486	5939	(13)	L. Uruk?	14 (BRB)	3G 60	-	Nvi	-	-	-	-
2487	5940	(16)	L. Uruk?	14 (BRB) (wasters)	3G 61	-	Nv	-	-	-	-
2488	5942	(3)	L. Uruk?	14 (BRB)	3G 61	-	Ni	-	-	-	-
2489	5943	(2)	L. Uruk?	14 (BRB)	3G 61	-	Nvi	-	-	-	-
2490	5943	(14)	L. Uruk?	14 (BRB) (wasters)	3G 61	-	-	-	-	-	-
2491	5946	(7)	L. Uruk?	14 (BRB)	3G 61	-	Ni	-	-	-	-

1	2	3	4	5	6	7	8	9	10	11	12
2492	5946	(12)	L. Uruk?	14 (BRB)	3G 61	-	Nvi	-	-	-	-
2493	5947		L. Uruk?	14 (BRB)	3G 61	-	Ni	-	-	-	-
2494	5948	(5)	L. Uruk?	14 (BRB)	3G 61	-	Nii	-	-	-	-
2495	5948		L. Uruk?	14 (BRB)	3G 61	-	Niii	-	-	-	-
2496	5948	(3)	L. Uruk?	14 (BRB)	3G 61	-	Niv	-	-	-	-
2497	5948	(6)	L. Uruk?	14 (BRB)	3G 61	-	Nv	-	-	-	-
14.1.1 Flat bases: string-cut (other)											
2498	5012	(2)	ED I?	14.1.1	2G 80	-	-	-	-	-	-
2499	5937		L. Uruk?	14.1.1 1.2?	3G 60	-	Bix	-	-	-	-
14.1.2 Flat or slightly convex bases											
2500	5030		ED I?	14.1.2	2G 21	-	-	-	-	-	-
2501	5031	(2)	ED I?	14.1.2	2G 11	-	-	-	-	-	-
2502	5034		ED I?	14.1.2	2G 11	-	-	-	-	-	-
2503	5083		ED I?	14.1.2	2G 24	-	Aiv	-	-	-	-
2504	5085		ED I?	14.1.2	2G 14	McAdam 1983, 61, fig.55 no.21	Aiv	-	-	-	-
2505	5408		ED I	14.1.2	2G 36b	-	Eiii	446	-	5/14	*
2506	5408	(17)	ED I	14.1.2	2G 36b	-	Aiv	-	-	-	-
2507	5408	(13)	ED I	14.1.2	2G 36b	-	Biii	-	-	-	-
2508	5408	(19)	ED I	14.1.2	2G 36b	-	Ei	-	-	-	-
2509	5411	(5)	ED I	14.1.2	2G 36d	-	Bii	-	-	-	-
2510	5411		ED I	14.1.2	2G 36d	-	Biii	469	-	24/36	-

1	2	3	4	5	6	7	8	9	10	11	12
2511	5412	(3)	ED I	14.1.2	2G 36d	-	Bii	-	-	-	-
2512	5412	(7)	ED I	14.1.2	2G 36d	-	Ei	-	-	-	-
2513	5413		ED I	14.1.2	2G 36d	-	Aiii	-	-	-	-
2514	5413	(2)	ED I	14.1.2	2G 36d	-	Ei	-	-	-	-
2515	5422	(2)	ED I	14.1.2	2G 36b	-	Ci	-	-	-	-
2516	5422	(5)	ED I	14.1.2	2G 36b	-	Cii	-	-	-	-
2517	5423	(3)	ED I	14.1.2	2G 36d	-	Aiv	-	-	-	-
2518	5423		ED I	14.1.2	2G 36d	-	Cii	-	-	-	-
2519	5523		E. ED I	14.1.2	2G 46d	-	Ci	-	-	-	-
2520	5544		Uruk	14.1.2	2G 46d	-	Hiii	-	-	-	-
2521	5547		Uruk	14.1.2	2G 46d	-	Bviii	-	-	2/1	-
2522	5553		Uruk	14.1.2	2G 46d	-	Bii	-	-	-	-
2523	5600		M/L. Uruk	14.1.2	3G 81all	-	Ci	-	-	-	-
2524	5601		M/L. Uruk	14.1.2	3G 81c	-	Aiv	515	-	1/7	-
2525	5601	(2)	M/L. Uruk	14.1.2	3G 81c	-	Bi	-	-	-	-
2526	5601		M/L. Uruk	14.1.2	3G 81c	-	Hiii	541	-	1/8	-
2527	5601	(4)	M/L. Uruk	14.1.2	3G 81c	-	Hx	-	-	-	-
2528	5601		M/L. Uruk	14.1.2	3G 81c	-	Ei	516	-	1/9	-
2529	5601	(5)	M/L. Uruk	14.1.2	3G 81c	-	Avii	-	-	-	-
2530	5601		M/L. Uruk	14.1.2	3G 81c	-	Aiv	517	-	1/10	-
2531	5601		M/L. Uruk	14.1.2	3G 81c	-	Biii	-	-	-	-

1	2	3	4	5	6	7	8	9	10	11	12
2532	5937		L. Uruk?	14.1.2	3G 60	-	Biii	-	-	-	-
2533	5937		L. Uruk?	14.1.2	3G 60	-	Hiii	-	-	-	-
2534	5941		L. Uruk?	14.1.2	3G 61	-	Hi	-	-	-	-
2535	5943	(3)	L. Uruk?	14.1.2	3G 61	-	Hi	-	-	-	-
2536	5925		Uruk?	14.1.2 8.3.3	3G 82	McAdam 1983, fig.129 no.69; 73	Hx	-	-	-	-
2537	5544		Uruk	14.1.2 13.1.1	2G 46d	-	Hix	-	-	-	-
2538	5550		Uruk	14.1.2 13.1.1	2G 46d	-	Bviii	-	-	-	-
2539	5523		E. ED I	14.1.2 13.1.2	2G 46d	-	Aiv	-	-	-	-
2540	5098		ED I?	14.1.2 13.3.1	2G 35	-	Ai	-	-	-	-
14.1.4 Convex bases											
2541	5547		Uruk	14.1.4	2G 46d	-	Piii	-	-	-	-
14.1.5 Flat bases: coarse ware											
2542	5030		ED I?	14.1.5	2G 21	-	Qii?	-	-	-	-
2543	5408		ED I	14.1.5	2G 36b	-	Qii	-	-	-	-
2544	5601		M/L. Uruk	14.1.5	3G 81c	-	Piii	506	-	1/6	*
2545	5601	(2)	M/L. Uruk	14.1.5	3G 81c	-	Pi	-	-	-	-
14.2 Round/ovoid bases											
2546	5553		Uruk	14.2	2G 46d	-	Aiv	-	-	-	-
2547	5601		M/L. Uruk	14.2	3G 81c	-	Aiv	518	-	4/21	-
2548	5550		Uruk	14.2 13.3.2	2G 46d	-	Ki	489	-	4/25 0/10	-

1	2	3	4	5	6	7	8	9	10	11	12
14.3 Ring bases											
2549	5004		ED I?	14.3	2G 80	-	-	-	-	-	-
14.3.1 Ring bases: pinched											
2550	5411		ED I	14.3.1	2G 36d	-	Diii	-	-	-	-
2551	5412		ED I	14.3.1	2G 36d	-	Bii	-	-	-	-
2552	5413		ED I	14.3.1	2G 36d	-	Bix	478	-	-	*
2553	5601		M/L. Uruk	14.3.1	3G 81c	-	Ci	499	-	4/17	*
2554	5947		L. Uruk?	14.3.1	3G 61	-	Ci	-	-	-	-
2555	5423		ED I	14.3.1.1	2G 36d	-	Ci	-	-	-	-
14.3.2 Ring bases: low											
2556	5029		ED I?	14.3.2	2G 31	-	-	-	-	-	-
2557	5031	(2)	ED I?	14.3.2	2G 11	-	-	-	-	-	-
2558	5090		ED I?	14.3.2	2G 65	-	Aiv	-	-	-	-
2559	5408	(3)	ED I	14.3.2	2G 36b	-	Bi	-	-	-	-
2560	5408	(12)	ED I	14.3.2	2G 36b	-	Bviii	-	-	-	-
2561	5408	(7)	ED I	14.3.2	2G 36b	-	Piii	-	-	-	-
2562	5412	(3)	ED I	14.3.2	2G 36b	-	Aiv	-	-	-	-
2563	5550		Uruk	14.3.2	2G 46d	-	Bi	486	-	5/2	-
2564	5553		Uruk	14.3.2	2G 46d	-	Aix	-	-	-	-
2565	5601		M/L. Uruk	14.3.2	3G 81c	-	Cii	498	-	4/20	*
2566	5601		M/L. Uruk	14.3.2	3G 81c	-	Av	521	-	4/16	-

1	2	3	4	5	6	7	8	9	10	11	12
2567	5601	M/L. Uruk	14.3.2	3G 81c	-	Aiv	519	-	4/14	-	*
14.3.3 Ring bases: high											
2568	5553	Uruk	14.3.3	2G 46d	-	Bii	-	-	-	-	-
2569	5600	M/L. Uruk	14.3.3	3G 81all	-	Bii	-	-	-	-	-
14.3.4 Ring bases: added											
2570	5098	ED I?	14.3.4	2G 35	c.f. McAdam 1983, 67 fig.133 no.175	Aviii	-	-	-	-	-
2571	5413	ED I	14.3.4	2G 36d	-	Eiii	-	-	-	-	-
2572	5551	Uruk	14.3.4	2G 46d	-	Bviii	-	-	-	-	-
2573	5601	M/L. Uruk	14.3.4	3G 81c	-	Bviii	-	-	6/9	-	*
KISH											
1	<u>Bowls</u>										
1.1	Conical bowls: rim diameter > 15.0cm										
2574	A 1924: 433	ED III	1.1	Grave 36 (A)	Mackay 1925, 20; 36	Bi	-	-	-	-	*
2575	A 1924: 747		1.1	Mound A	-	Gii	-	-	-	-	*
1.1	Conical bowls: rim diameter < 15.0cm										
2576	A 1925: 219	ED III	1.1	Grave 135 (A)	-	Ai	-	-	-	-	*
2577	A 1925: 218	ED III	1.1	Grave 135 (A)	-	Ai	-	-	-	-	*
2578	A 1924: 271	ED III	1.1	-	-	Aii	-	-	-	-	*
2579	Birmingham 305'61 Kish 1924: 431	ED III	1.1	-	-	Aiii	-	-	-	-	*
2580	A 1924: 432	ED III?	1.1	-	-	Aii	-	-	-	-	*

1	2	3	4	5	6	7	8	9	10	11	12
2581	A 1924: 430	ED IIIA?	1.1	Room 14 (Palace)	Mackay 1925, 86; 87 Moorey 1978, M 1, 805	Aii	-	-	-	-	*
1.2 Transitional bowls											
2582	A 1924: 178	ED III?	1.2.4	Mound A	-	Bi	-	-	-	-	*
2583	A 1924: 177	ED III?	1.2.4	Mound A	-	Bi	-	-	-	-	-
2584	A 1924: 176	ED III?	1.2.4	Mound A	-	Bi	-	-	-	-	-
1.3 Goblets											
1.3.3 Goblets: other											
2585	A 1930: 244	ED III	1.3.3	Y sounding	Moorey 1978, M 2, C 12	Ci	063	-	20/14	-	*
Bevel-rim-bowl (BRB)											
2586	A 1925: 400	Uruk?	BRB	Mound A?	-	Gii	-	-	-	-	*
1.4 Cups											
1.4.1 Cup: flat base											
2587	A 1924: 180	ED III	1.4.1	Mound A	-	Aiii	-	-	-	-	*
1.4.3 Cup: round base; tall											
2588	A 1924: 274	ED III	1.4.3	Grave 28 (A)	Mackay 1925, 32; pl.15 no.H5 Moorey 1978, M 1, D11	Bii	-	-	-	-	*
1.5 Large bowls: flat base											
1.5.1 Platter											
2589	A 1929: 330	ED II	1.5.1	Grave 524 (Y)	Moorey 1966, pl. 8 Moorey 1978, M 2, F05	Bii	-	-	-	-	*
1.5.2 Dishes											
2590	A 1930: 238a	ED III?	1.5.2 1.14.3.1 8.17.1	-	-	Hiv	070	-	20/24	-	*

1	2	3	4	5	6	7	8	9	10	11	12
2591	A 1930: 193a	ED II?	1.5.2 1.14.7.3 13.1.1 8.17	B/C trench	Moorey 1978, M 2, B08	Avi	017	-	-	-	*
1.6 Round-based bowls/basins											
1.6.1 Round-based bowls: small											
2592	A 1930: 237a	ED II	1.6.1 13.1.1 8.17.6	Y sounding	-	Ci	065	-	-	-	*
1.9 Sieve bowls											
1.9.1 Sieve bowls: flat base											
2593	A 1924: 185	ED III	1.9.1	-	Mackay 1929, pl.54 no.34 Moorey 1978, M 1, 1305	Ai	-	-	-	-	*
2594	A 1929: 341	ED II	1.9.1	Grave 473 (Y)	Moorey 1978, M 2, E 11	Ci	-	-	-	-	*
1.9.2 Sieve bowls: round base											
2595	A 1924: 341	ED III	1.9.2	Mound A	Mackay 1929, pl.54 no.36	Avi	-	-	-	-	*
2596	A 1925: 341	ED II	1.9.2	Grave 106 (A)	Moorey 1978, M 1, D 11	Ai	-	-	-	-	*
1.9.4 'Strainer'											
2597	A 1925: 346	ED III	1.9.4	-	Mackay 1929, pl.54 no.33	Ai	-	-	-	-	*
1.10 Moulded bowls											
1.10.1 Moulded bowls: round											
2598	A 1925: 340	ED III	1.10.1	Mound A	Mackay 1929, 208; pl.45 no.4	Aiii	-	-	-	-	*
2599	Birmingham 284'61 Kish 2067	ED III?	1.10.1	-	-	Aii	-	-	-	-	*
2600	Birmingham 285'61 Kish 2062	ED III?	1.10.1	-	-	Aiv	-	-	-	-	*

1	2	3	4	5	6	7	8	9	10	11	12
2601	A 1924: 237	ED III	1.10.1	Mound A	-	Aii	-	-	-	-	*
1.10.2 Moulded bowls: square											
2602	Birmingham 286'61 Kish 2063	ED III?	1.10.2	-	-	Ai	-	-	-	-	*
1.11 Bowl with perforated rim											
2603	A 1925: 229 2835 A	ED III	1.11	Mound A	Mackay 1929, 151, pl.52 no.46 Moorey 1978, M 1, D11	Ai	-	-	-	-	*
1.12 Grey burnished bowls											
2604	A 1930: 236b	ED II	1.12	Y sounding	Moorey 1978, M 2, D05	Hii	071	-	-	-	*
2605	A 1930: 201	ED II	1.12	Y sounding	Watelin 1934, 13	Hi	057	A174	-	51/25	-
1.13 Painted bowls											
2606	A 1930: 181	ED III	1.13 1.14.8.1 13.2.6	B/C trench	Moorey 1978, M 2, B08	Cii	062	-	-	51/27	*
2607	A 1929: 659	ED III?	1.13 1.14.8.7 13.2.5	Ingharra	Moorey 1978, M 2, A14	Ii	073	-	20/27	-	*
2 Jars											
2.1 Small jars											
2.1.1 Small jars: flat base (string-cut)											
2608	A 1924: 759	ED III	2.1.1.1	Mound A	Mackay 1925, pl.15 no.31	Aiii	-	-	-	-	-
2609	A 1925: 343	ED III	2.1.1.1	Grave 123 (A)	Mackay 1929, pl.44 no.10 Moorey 1978, M 1, D11	Ai	-	-	-	-	*
2610	A 1924: 731	ED III	2.1.1.1	Grave 21 (A)	Mackay 1925, 20; 36; pl.15 no.24	Aiii	-	-	-	-	*
2611	Birmingham 288'61 1924: 179	ED III?	2.1.1.1	-	-	Aiii	-	-	-	-	*

1	2	3	4	5	6	7	8	9	10	11	12
2612	A 1924: 181	ED III	2.1.1.1	Grave 30 (A)	Mackay 1925, 20; 36; pl.15 no.19	Aii	-	-	-	-	-
2613	A 1924: 435	ED III	2.1.1.1	Grave 28 (A)	Mackay 1925, 20; 36; pl.15 no.22 Moorey 1978, M 1, D11	Aiv	021	-	-	51/20	*
2614	A 1925: 221	ED III	2.1.1.1	Grave 135 (A)	-	Ai	-	-	-	-	*
2615	A 1924: 181	ED III	2.1.1.1	Grave 30 (A)	Mackay 1925, 20; 36; pl.15 no.23	Cii	-	-	-	-	-
2616	Birmingham 289'61 Kish 2055	ED III?	2.1.1.1.5	-	-	Aii	-	-	-	-	*
2.1.2 Small jars: round base											
2617	A 1925: 223 2706H	ED III	2.1.2.1	Grave 135 (A)	Mackay 1929, pl.53 no.24	Ai	-	-	-	-	*
2618	A 1924: 743	ED III	2.1.2.4	Grave 18 (A)	Mackay 1925, 20; 36; pl.16 no.23	Aii	-	-	-	-	-
2.1.3 Small jars: ring base											
2619	A 1924: 202	ED III	2.1.3 13.1.1	Mound A	-	Avi	-	-	-	-	*
2.2 Medium jars											
2.2.1 Medium jars: round base											
2620	A 1925: 331	ED III	2.2.1.1	Grave 123 (A)	Mackay 1929, pl.44 no.10	Biii	078	-	-	51/33	*
2621	A 1924: 732	ED III	2.2.1.3	Mound A	Mackay 1925, pl.16 no.4	Ai	-	-	-	-	*
2622	A 1925: 239	ED III	2.2.1.5	Grave 152 (A)	Moorey 1978, M 1, D11	Ci	-	-	-	-	*
2623	A 1924: 277	ED III	2.2.1.8	Grave 28 (A)	Mackay 1925, 20; 36; pl.16 no.12 Moorey 1978, M 1, D11	Ai	-	-	-	-	-
2624	A 1929: 309	ED II	2.2.1.8	Grave 539 (Y)	Moorey 1978, M 2, E11	Aiii	-	-	-	-	*

1	2	3	4	5	6	7	8	9	10	11	12
2.2.2 Medium jars: flat base											
2625	A 1929: 369	ED IIIA?	2.2.2.3	Grave 479 (Y)	Moorey 1978, M 2, E12	Aiii?	-	-	-	-	*
2626	Birmingham 286'61 Kish 1924: 182	ED III	2.2.2.3	Mound A	Mackay 1925, pl.16 no.17	Ai	-	-	-	-	*
2627	A 1924: 174	ED III	2.2.2.7	Mound A	Mackay 1925, pl.15 no.45	Ai	-	-	-	-	*
2628	A 1924: 742	ED III	2.2.2.7	Grave 24 (A)	Mackay 1925, 20; 36; pl.15 no.41 Moorey 1978, M 1, D11	Biii	-	-	-	-	-
2629	A 1924: 172	ED III	2.2.2.7	Mound A	Mackay 1925, pl.15 no.44	Bi	-	-	-	-	-
2630	Birmingham 290'61 Kish 1924: 729	ED II?	2.2.2.8	-	Mackay 1925, pl.15 no.14	Cii	-	-	-	-	*
2.2.3 Medium jars: ring base											
2631	A 1932: 971	ED II?	2.2.3.2 13.1.1	Y sounding	Moorey 1978, M 2, C12	Cii	-	-	-	-	-
2632	A 1925: 236	ED III	2.2.3.3	Grave 123 (A)	Mackay 1929, pl.44 no.10	Ai	-	-	-	-	*
2633	A 1925: 231	ED III	2.2.3.4.1	Mound A	Mackay 1929, pl.52 no.40 Moorey 1978, M 1, D11	Ai Aix	-	-	-	-	*
2.3 Large jars											
2.3.3 Large jars: round base											
2634	A 1925: 228 1582 B	ED III	2.3.3.1 8.8.1	Grave 40 (A)	Mackay 1929, pl.53 no.53 Moorey 1978, M 1, D11	Ai	-	-	-	-	-
2635	A 1924: 767	ED III	2.3.3.1 8.9.2	Area P	Moorey 1978, M 1, B05	Aiv	-	-	-	-	*
2.3.4 Large jars: ring base											
2636	A 1925: 222 2076 G	ED III	2.3.4.1	Grave 135 (A)	-	Bi	-	-	-	-	*
2637	A 1924: 224 2706 I	ED III	2.3.4.1 14.3.4	Mound A	-	Avi	079	-	-	-	*

1	2	3	4	5	6	7	8	9	10	11	12
2638	A 1925: 216 2706 A	ED III	2.3.4.1 14.3.4	Grave 135 (A)	-	Bi Bvii	-	-	-	-	*
2639	A 1925: 220 2706 E	ED III	2.3.4.1 14.3.4	Grave 135 (A)	-	Biii Bv	-	-	-	-	*
2640	A 1924: 273	ED III	2.3.4.2	Grave 2 (A)	Mackay 1925, 20; 36; pl.13 no.10	Di	092	-	21/09	-	-
2641	Birmingham 280'61 Kish 1924: 272	ED III	2.3.4.2 14.3.4	-	-	Bi Bvii	-	-	-	-	*
2642	A 1924: 736	ED III	2.3.4.2 14.3.4 8.8.4	Grave 17 (A)	Mackay 1925, 20; 36; pl.13 no.22	Biii Bv	-	-	-	-	-
2643	A 1929: 342	ED II?	2.3.4.2 14.3.4 8.17.5	Grave 473 (A)	Moorey 1978, M 2, E11	Ciii Aiii	-	-	-	-	-
2644	A 1924: 768	ED III	2.3.4.4 14.3.4	Grave 34 (A)	Mackay 1925, 20; 36; pl.13 no.4 Moorey 1978, M 1, D09	Aii	007	-	-	-	-
2645	A 1925: 212 2090 A	ED III	2.3.4.4 14.3.4 8.5.8	Grave 149 (A)	Mackay 1929, pl.51 no.11 Moorey 1978, M 1, D09	Avi Aix	026	-	19/22	-	-
2646	A 1924: 261	ED III	2.3.4.5 14.3.4	Grave 38 (A)	Mackay 1925, 20; 36; pl.13 no.20 Moorey 1978, M 1, D09	Aii Aix	-	-	-	-	-
2647	A 1925: 269 1964 M	ED III	2.3.4.7	Grave 56 (A)	Mackay 1929, pl.44 no.12; pl.50 no.55 Moorey 1978, M 1, D11	Biv	075	A83	20/30	-	*
2.4 Jar rim sherds											
2.4.1 Jar rim sherds: hole-mouthed											
2648	A 1930: 191	Uruk?	2.4.1.1	Y sounding	-	Fi	106	-	21/36	53/13 53/14	*
2649	A 1930: 243d	E. ED I?	2.4.1.1 8.4.2.3 8.13.1	Y sounding	Moorey 1978, H 2, C12	Aii	006	-	19/08	-	*
2650	A 1930: 241a	E. ED I?	2.4.1.1 8.6.7	Y sounding	Moorey 1978, M 2, C12	Aiv	035	-	19/03	51/21	*
2651	A 1930: 250	Uruk?	2.4.1.2	Y sounding	Moorey 1978, M 2, C14	Av	055	-	-	51/24	*

1	2	3	4	5	6	7	8	9	10	11	12
2652	A 1930: 240c	ED I?	2.4.1.6 8.4.1.2 8.6.2.1	Y sounding	Moorey 1978, M 2, D05	Ei	043	-	-	-	*
2653	A 1930: 246c	ED I	2.4.1.6 8.4.1.5 8.5.2	Y sounding	Moorey 1978, M 2, C12	Ei	004	-	-	-	*
2654	A 1930: 243b	Uruk?	2.4.1.6 8.4.1.5 8.5.2 8.5.8	Y sounding	Moorey 1978, M 2, C12	Gi	097	-	21/17	51/37	*
2655	A 1930: 243a	ED I?	2.4.1.6 8.4.1.5 8.6.2.1	Y sounding	Moorey 1978, M 2, C12	Avi	036	-	-	-	*
2656	A 1930: 243c	ED I?	2.4.1.6 8.7.1	Y sounding	Moorey 1978, M 2, C12	Avi	050	-	-	-	*
2657	A 1930: 240e	ED I?	2.4.1.6 8.7.1	C trench	Moorey 1978, M 2, C05	Ei	100	-	21/26	-	*
2.4.5 Jar sherds: bevelled rim											
2658	A 1930: 243g	ED II?	2.4.5.8 8.6.9	Y sounding	Moorey 1978, M 2, C12	Bii	090	-	21/06	51/34	*
2659	A 1930: 247c	ED II?	2.4.5.9	Y sounding	Moorey 1978, M 2, C14	Avii	023	-	-	-	*
2.4.8 Jar sherds: flat rim											
2660	A 1930: 241c	ED I/II?	2.4.8.8 8.9.4	Y sounding	Moorey 1978, M 2, C12	Ei	003	-	-	-	*
2661	A 1930: 248a	ED III	2.4.8.9	Y sounding	Moorey 1978, M 2, C14	Aii	015	-	-	-	*
2.4.9 Jar sherds: coarse ware rims											
2662	A 1930: 195	ED III	2.4.9.6 13.1.1	B/C trench	Moorey 1978, M 2, B08	Ciii	066	-	20/15	51/28	*
2.6 Lids											
2.6.1 Flat lid											
2663	A 1924: 234 1377	ED III?	2.6.1	-	Mackay 1929, 209, pl.59 no.32	Hiii	-	-	-	-	*

1	2	3	4	5	6	7	8	9	10	11	12
2.6.2 Rounded 'lids'/'bunges'											
2664	A 1929: 302	ED III	2.6.2	Y sounding	Moorey 1978, M 2, C12	Avii	-	-	-	-	*
2665	A 1929: 301	ED III	2.6.2	Y sounding	Moorey 1978, M 2, C12	Avii	-	-	-	-	*
3 Bottles											
3.2 Bottles: everted rim											
2666	A 1926: 352	ED III	3.2	Grave 4 (A)	Mackay 1925, 20; 36; pl.16 no.27 Moorey 1978, M 1, D11	Aviii	-	-	-	-	*
2667	A 1929: 372	ED III	3.2	Grave 479 (Y)	Moorey 1978, M 2, F05	Ci	068	-	-	51/29	*
2668	A 1929: 371	ED III	3.2 8.17.5	Grave 479 (Y)	Moorey 1978, M 2, F05	Ciii	-	-	-	-	*
3.4 Bottle: carinated shoulder and square body											
2669	A 1924: 216	ED IIIB?	3.4	-	Mackay 1925, pl.16 no.30	Av	054	-	-	-	*
3.6 Bottle: ovoid body											
2670	A 1924: 207	ED III	3.6	Mound A	Mackay 1925, pl.16 no.10	Avii	-	-	-	-	*
4 'Drinking bottles'											
4.1 'Drinking' bottle: double mouthed											
2671	A 1925: 284 2573	Akkad?	4.1	Mound A	Mackay 1929, 151; pl.52 no.34	Ci	-	-	-	-	*
5 Spouted jars											
5.1 Spouted jars: flat base											
5.1.1 Small spouted jars: flat base											
2672	A 1929: 370	ED III	5.1.1.2	Grave 479 (Y)	Moorey 1978, M 2, F05	Ci	-	-	-	-	*
2673	A 1929: 308	ED III	5.1.1.2	Grave 539 (Y)	Moorey 1978, M 2, E11	Aiv	-	-	-	-	*

1	2	3	4	5	6	7	8	9	10	11	12
5.1.3 Spouted jar: flat base, carinated shoulder											
2674	A 1924: 730	ED III	5.1.3	Grave 24 (A)	Mackay 1925, 20; 36; pl.14 no.4	Ii	074	-	-	-	*
5.1.4 Spouted jar: flat base, round shoulder, tall											
2675	A 1929: 373	ED I/II?	5.1.4	Grave 479 (Y)	Moorey 1978, M 2, F05	Bi	-	-	-	-	*
2676	A 1929: 374	ED I/II?	5.1.4	Grave 479 (Y)	Moorey 1978, M 2, F05	Bi	080	-	20/31	-	*
5.2 Spouted jars: convex base											
5.2.1 Spouted jars: convex base, round shoulder, tall (short spout)											
2677	A 1931: 215	ED I/II?	5.2.1	Grave 612 (Y)	Moorey 1978, M 2, E11	Bi	-	-	-	-	-
5.2.2 Spouted jar: convex base, carinated shoulder											
2678	A 1929: 375	ED I/II?	5.2.2	Grave 479 (Y)	Mackay 1925, 29; pl.14 no.1 Moorey 1978, M 2, F05	Aviii	-	-	-	-	*
5.3 Spouted jars: ring base											
5.3.1 Spouted jar: ring base, plain rim											
2679	A 1925: 232	ED IIIA?	5.3.1	Grave 81 (A)	Mackay 1925, pl.51 no.19 Moorey 1978, M 1, D11	Ai	005	A60	-	-	*
5.3.3 Spouted jar: ring base, carinated shoulder											
2680	A 1924: 183 1246	ED IIIA?	5.3.3	Mound A	Mackay 1925, 30; pl.14 no.3	Bi	-	-	-	-	-
5.7 Spouted jar sherds: spouts											
2681	A 1930: 215	ED III	5.7	C trench	Moorey 1978, M 2, C05	Aiii? (Burnt)	056	-	20/08	-	*
2682	A 1930: 246a	ED I/II?	5.7 8.6.2	Y sounding	Moorey 1978, M 2, C12	Ei	033	-	19/06	-	*

1	2	3	4	5	6	7	8	9	10	11	12
2683	A 1930: 240a	ED I/II?	5.7 8.6.2 8.5.4	Y sounding	Moorey 1978, M 2, D05	Aii	014	-	19/14	-	*
5.7.9 Double spouts											
2684	A 1930: 168	ED III	5.7.9	Y sounding	c.f. Delougaz 1952, pl.184 C555.522 Moorey 1978, M 2, D05	Ai	002	-	18/38	-	*
6 <u>Wing-lugged jars</u>											
6.1 Small wing-lugged jars											
6.1.1 Small wing-lugged jar: plain lug											
2685	A 1929: 327	ED I/II?	6.1.1	Grave 524 (Y)	Moorey 1978, M 2, F05	Ci	-	-	-	-	*
2686	A 1929: 328	ED I/II?	6.1.1	Grave 521 (Y)	Moorey 1978, M 2, F05	Aiv	-	-	-	-	*
2687	A 1929: 310	ED I?	6.1.1	Grave 539 (Y)	Moorey 1978, M 2, E11	Aviii	-	-	-	-	*
6.2 Wing-lugged jar: pinched ring base											
2688	A 1929: 314	ED I?	6.2	Grave 535 (Y)	Moorey 1978, M 2, F09	Aviii	-	-	-	-	*
7 <u>Footed/cup-based jars (Pedestal jars)</u>											
7.1 Footed jars: plain											
2689	A 1925: 240 2577 F	ED III?	7.1	Grave 123 (A)	Mackay 1929, pl.44 no.10	Ai Aix	-	-	-	-	*
2690	A 1925: 242 2577 F	ED III	7.1	Grave 123 (A)	Mackay 1929, pl.44 no.10 Moorey 1978, M 1, D11	Aiv Aix	-	-	-	-	*
2691	Birmingham 781'61 Kish 1924: 748	ED III?	7.1	-	Mackay 1925, pl.14 no.16	Bii Bvii	284	-	-	-	*
2692	A 1924: 429	ED IIIB	7.1	Grave 9 (A)	Mackay 1925, 20; 36; pl.14 no.8	Bii	089	-	-	-	-

1	2	3	4	5	6	7	8	9	10	11	12
7.2 Footed jars: decorated with white inlay											
2693	A 1924: 769	ED IIIB	7.2	Mound A	Langdon 1924, 66; pl.7 fig.1 Mackay 1925, 31; pl.1 fig.3; pl.14 no.6	Ei	-	-	-	-	-
2694	A 1925: 267	ED IIIB	7.2	'A' Palace Room 56	Mackay 1929, 208; pl.45 no.5; pl.52 no.9 Moorey 1978, M 1, D11	Hi?	-	-	-	-	-
8 <u>Body sherds (jars)</u>											
8.4 Lugged jar sherds											
8.4.1 Lugged jar sherd: lug perforated											
2695	A 1930: 243e	Uruk?I	8.4.1.2 8.13.5 8.6.9	Y sounding	Moorey 1978, M 2, C12	Bv	086	-	-	-	*
8.4.2 Lugged jar sherd: plain lug											
2696	A 1930: 247b	ED I?	8.4.2.2 8.6.9	Y sounding	Moorey 1978, M 2, C14	Av	048	-	-	-	*
8.5 Incised decoration											
2697	A 1930: 240d	E. ED I?	8.5 8.6.1	Y sounding	Moorey 1978, M 2, D05	Bvi	093	-	-	51/36	*
8.5.2 Incised decoration: cross-hatched											
2698	A 1930: 240b	ED I?	8.5.2 8.6.2.1 8.12.1	Y sounding	Moorey 1978, M 2, D05	Eii	039	-	19/24	-	*
8.5.4 Incised decoration: herringbone											
2699	A 1930: 243j	ED I/II?	8.5.4 8.6.2.1	Y sounding	Moorey 1978, M 2, C12	Aii	020	-	19/16	-	*
8.6 Impressed decoration											
8.6.5 Impressed circles											
2700	A 1929: 135a	ED I?	8.6.5 8.9.5	C trench	Moorey 1978, M 2, C05	Ei	040	-	-	-	*

1	2	3	4	5	6	7	8	9	10	11	12
8.7 Cut ware											
8.7.2 Cut ware with incised cross-hatched decoration											
2701	A 1930: 246b	ED I?	8.7.2 8.6.1.1	Y sounding	Moorey 1978, M 2, C12	Ai	032	-	-	51/31	*
2702	A 1930: 243f	ED I?	8.7.2 13.1.1?	Y sounding	Moorey 1978, M 2, C12	Av	053	-	-	-	*
8.9 Reserve-slipped decoration											
8.9.1 Diagonal reserve slip											
2703	A 1930: 243h	ED I?	8.9.1 8.6.2.1	Y sounding	Moorey 1978, M 2, D05	Aiv	052	-	-	51/23	*
2704	A 1930: 235a	ED II/III?	8.9.1 8.12.1	Y sounding	Moorey 1978, M 2, D05	Ai	013	-	19/12	-	*
8.9.2 Horizontal reserve slip											
2705	A 1929: 135c	ED II?	8.9.2	Y sounding	Moorey 1978, M 2, C14	Aiii	022	-	-	-	*
2706	A 1929: 135d	ED II?	8.9.2	Y sounding	Moorey 1978, M 2, C14	Aiv	027	-	-	-	*
2707	A 1930: 235b	ED II?	8.9.2 8.6.1	Y sounding	Moorey 1978, M 2, D05	Bii	076	-	-	-	*
2708	A 1930: 235g	ED I?	8.9.1 8.6.7	Y sounding	Moorey 1978, M 2, D05	Avi?	072	-	-	-	*
2709	A 1930: 235f	ED II?	8.9.2 8.12.1	Y sounding	Moorey 1978, M 2, D05	Aii	018	-	-	-	*
2710	A 1930: 242b	ED II?	8.9.2 8.13.1	Y sounding	Moorey 1978, M 2, C12	Bi	087	-	-	-	*
8.9.4 Diagonal-cross-horizontal reserve slip											
2711	A 1930: 235d	ED I?	8.9.4 8.6.2	Y sounding	Moorey 1978, M 2, D05	Avi	016	-	-	-	*

1	2	3	4	5	6	7	8	9	10	11	12
8.13 Decorated ribs: cable/piecrust											
8.13.5 Several cable ribs: vestigial											
2712	A 1930: 243i	ED I?	8.13.5	Y sounding	Moorey 1978, M 2, C12	Avi	038	-	-	-	*
8.16 Decorated coarse ware (large jars)											
2713	A 1930: 248b	ED III?	8.16	Y sounding	Moorey 1978, M 2, C14	Av	049	A125A A125B	19/27	-	*
8.16.2 Coarse ware: single cable rib											
2714	A 1930: 242c	ED I?	8.16.2 8.5	Y sounding	Moorey 1978, M 2, C12	Biv	101	-	21/29	53/4 53/5	*
2715	A 1930: 389 Bitumen sample (2715)	ED I?	8.16.2.1	Y sounding	Moorey 1978, M 2, C12	Diii -	098 631	- -	21/19 -	51/38 53/1 53/2	* - -
8.17 Burnished											
8.17.5 Pattern-burnished: cross-hatching											
2716	A 1929: 391 (see also 2668)	ED III	8.17.5	Y sounding	Moorey 1978, M 2, C14	Ci	061	-	-	-	*
2717	A 1930: 238b	ED III	8.17.5	Y sounding	Moorey 1978, M 2, D05	Hiii	099	-	21/25	53/3	*
8.20 Carinated shoulder sherds											
2718	A 1930: 241b	ED I/II?	8.20 8.6.2.1 8.7.3 8.9.1	Y sounding	Moorey 1978, M 2, C14	Bii	088	-	21/02	-	*
2719	A 1929: 135b	ED II?	8.20 8.8.4	Y sounding	Moorey 1978, M 2, C14	Aiv	041	-	-	-	*
9 Upright handled jars											
2720	A 1924: 761 1252 C	ED III	9	Grave 18 (A)	Mackay 1925, 20; 36; pl.19 no.5 Moon 1982, 40-41, fig.2 no.4	Ai Aix	-	-	-	-	-
2721	A 1924: 209	ED III	9	Grave 3 (A)	Mackay 1925, 20; 36; pl.9 no.9 Moon 1982, 40-41, fig.2 no.5	Ai Aix	-	-	-	-	-

1	2	3	4	5	6	7	8	9	10	11	12
2722	A 1925: 237 1582 F	ED I/II?	9	Grave 40 (A)	Mackay 1925, pl.48 no.4 Moon 1982, 40-41, fig.2 no.3	Eiii Eiv	059 059	A85	19/34	-	*
2723	A 1929: 329	ED II?	9	Grave 524 (Y)	Moon 1982, 40-41, fig.2 no.1 Moorey 1978, M 2, F05	Aiv	-	-	-	-	-
2724	A 1930: 198	ED II?	9	Y sounding	Moon 1982, 40-41, fig.2 no.2 Moorey 1978, M 2, C14	Aii	-	-	-	-	-
2725	A 1925: 230 2016 A	ED III	9	Grave 65 (A)	Mackay 1929, pl.48 no.21 Moorey 1978, M 1, D09	Ai	-	-	-	-	*
2726	A 1980: 202	ED III?	9	-	-	Aiii	-	-	-	-	*
2727	A 1925: 227 2577c	ED III	9	Grave 123 (A)	Mackay 1929, pl.48 no.10 Moorey 1978, M 1, D09	Ai Aix	-	-	-	-	-
2728	BM 1932-2-2, 123253 Kish	ED III?	9	-	Mackay 1925, pl.10 no.16	Ai Aix	-	-	-	-	*
2729	A 1925: 217 2076 B	ED III	9	Grave 135 (A)	Moon 1982, 41-42, fig.2 no.6	Iii Bvii	091	-	-	-	-
2730	A 1925: 211 2133 B	ED III	9	Grave 75 (A)	Mackay 1929, pl.44 no.7 Moon 1982, 41-42, fig.2 no.7 Moorey 1978, M 1, D09	Bi Bvii	-	-	-	-	*
2731	A 1925: 210 1912 B	ED III	9	Grave 53 (A)	Mackay 1929, pl.45 no.11; pl.48 no.24	Ai Aix	-	-	-	-	-
2732	A 1931: 986	ED III?	9	Y sounding	Moorey 1978, M 2, C14	Ai Aix	-	-	-	-	*
9	<u>Upright-handled jar sherds</u>										
2733	A 1930: 252	ED II?	9? 8.5.2 8.6.2 8.13.1	Ingharra	Moorey 1978, M 2, C09	Fii	103	-	-	53/8 53/9	*
2734	A 1930: 247a	ED II?	9? 8.13.1 8.5	Y sounding	Moorey 1978, M 2, C14	Ai	009	-	-	51/18	*
2735	A 1930: 243h	ED II?	9? 8.13.2 8.5	Y sounding	Moorey 1978, M 2, C12	Aiii	069	-	-	51/30 51/32	*

1	2	3	4	5	6	7	8	9	10	11	12
9.1 Upright-handled jar handles											
2736	A 1925: 171	ED III?	9.1	-	Moon 1982, 42-43, fig.3 no.13 Moorey 1978, M 1, G10	Aiv	-	-	-	-	*
2737	A 1925: 215 2702 N	Akkad.?	9.1	-	Mackay 1929, pl.45 no.13.6 Moorey 1978, M 1, G10	Bi	-	-	-	-	*
2738	A 1925: 165	ED III	9.1	Mound A	Mackay 1929, pl.45 no.6 Moorey 1978, M 1, G10	Aiii	-	-	-	-	*
2739	A 1925: 168 2451 D	ED III	9.1	Grave 110 (A)	Moon 1982, 42-43, fig.3 no.11 Moorey 1978, M 1, G10	Avii	-	-	-	-	*
2740	A 1925: 170	ED III	9.1	Mound A	Mackay 1929, pl.45 no.7 & 13.3 Moorey 1978, M 1, G10	Avii	-	-	-	-	*
2741	A 1925: 167	ED IIIB?	9.1	Mound A	Mackay 1929, pl.45 no. 13.3 Moorey 1978, M 1, G10	Cii Aix	-	-	-	-	*
2742	A 1925: 163 1984 A	ED III	9.1	Grave 61 (A)	Mackay 1929, pl.45 no. 8 Moorey 1978, M 1, G10	Ai Aix	025	A86	19/19	-	*
2743	A 1925: 166 2166 D	ED III	9.1	Mound A	Mackay 1929, pl.45 no. 10.5 Moorey 1978, M 1, G10	Ai	-	-	-	-	*
2744	A 1930: 241d	Akkad.?	9.1	C trench	c.f. Moon 1982, pl.2 Moorey 1978, M 2, C05	Ci	060	A95	20/11	-	*
2745	A 1925: 164 2922 B	ED III?	9.1	-	-	Ai	045	-	-	51/22	*
10 Stemmed dishes											
10.1 Stemmed dishes: plain											
2746	A 1925: 235 2577 G	ED III	10.1	Grave 123 (A)	Mackay 1929, pl.44 no. 10 Moon 1982, 44-45, fig.4 no.15 Moorey 1978, M 1, D09	Ai	-	-	-	-	*
2747	A 1925: 234 2263	ED III	10.1	-	Mackay 1929, pl.49 no. 8 Moon 1982, 44-45, fig.4 no.16	Avii	-	-	-	-	*
2748	A 1924: 428	ED III	10.1 10.7.2	Grave 9 (A)	Mackay 1925, pl.11 no. 3	Ai	-	-	-	-	-

1	2	3	4	5	6	7	8	9	10	11	12
2749	Birmingham 280'61 Kish 1924: 278	ED III?	10.1 10.7.3	Grave 29? (A)	Mackay 1925, 20; 20-27; 36; pl.11 no.5	Ai	-	-	-	-	*
10.2	Stemmed dishes: incised, geometric decoration										
2750	A 1924: 437	ED III	10.2 10.7.4	Grave 29 (A)	Langdon 1924, pl.14 no.4 Mackay 1925, 20; 25-27; 36; pl.12 no. 20 Moorey 1978, M 1, D09	Avii	-	-	-	-	*
10.2.1	Stemmed dishes: incised, geometric decoration; ribbed and/or perforated										
2751	A 1925: 225 2706 K	ED III	10.2.1 10.7.3	Grave 135 (A)	-	Ai	034	-	-	-	*
2752	BM 1932-12-12, 1 123252 Kish 2408 E	ED III	10.2.1 10.7.3	-	Mackay 1929, pl. 50 no.4	Ai	-	-	-	-	*
10.3	Stemmed dish; incised decoration; flora										
2753	A 1927: 3296	ED III	10.3	Ingharra	Moorey 1978, M 2, A12	Avii	-	-	-	-	*
10.5	Stemmed dish: incised decoration; flora, fauna, architecture and/or female attributes										
2754	A 1924: 235	ED III?	10.5	Mound A	c.f. Mackay 1929, pl.45 no.10	Bv (Ur)	-	-	-	-	*
10.7	Stemmed dish rims										
10.7.4	Stemmed dish rim: notched rim and 'wavy-line' decoration										
2755	Y 74 (see also 2750)	ED III	10.7.4	Y sounding	c.f. Mackay 1925, pl.12 no.20	Ai	012	-	-	-	*
11	<u>Hollow stands</u>										
11.1	Small perforated stand ('wash-stand')										
2756	A 1924: 276 553 G	ED III	11.1	Room 1 Area P	Moorey 1978, M 1, B05; D11	Avii	-	-	-	-	*
11.4	Hollow stand: ribbed and fenestrated										
2757	A 1930: 245	ED II?	11.4? 8.7	Y sounding	Moorey 1978, M 12, C12	Biii	081	-	-	-	*

1	2	3	4	5	6	7	8	9	10	11	12
11.8 Hollow stand: cut ware											
2758	A 1927: 619	L. ED III	11.8	Ingharra (YW)	Mackay 1933, 335 Moorey 1978, M 2, C09	Avi	-	-	-	-	-
11.9 Lipped stands											
2759	A 1925: 233 2702 F	ED III	11.9 Lip	Grave 147 (A)	Mackay 1929, 214-215, pl.54 no.31 Moorey 1978, M 1, D11	Ai Aix	-	-	-	-	*
2760	A 1925: 238 2242 Q	ED III	11.9 Lip	Grave 87 (A)	Mackay 1929, pl.54 no.30	Avii Aix	-	-	-	-	*
12 Miniatures											
12.1 Miniature bowl/goblet											
12.1.1 Miniature bowl/rim perforated											
2761	A 1925: 355 2594 C	ED III	12.1.1	Mound A	Mackay 1929, pl.54 no.43	Cii	-	-	-	-	*
12.2 Miniature cup											
12.2.1 Miniature 'horn-cup': rim perforated											
2762	A 1925: 354 2146 A	ED III	12.2.1	Mound A	Mackay 1929, 151; pl.52 no.29	Ci	-	-	-	-	*
12.3 Miniature 'bag-pot' or 'thumb-pot'											
2763	Birmingham 299'61 Kish 1924: 740	ED III?	12.3	-	-	Avii	-	-	-	-	*
12.3.1 Miniature 'thumb-pot' with perforated tabs											
2764	A 1925: 286 2088	ED III	12.3.1	Mound A	Mackay 1929, pl.52 no.36	Av	-	-	-	-	*
12.4 Miniatures: jars											
12.4.1 Miniature jars with perforated neck											
2765	A 1924: 749	ED III	12.4.1	Mound A	Mackay 1925, pl.15 no.12	Cii	-	-	-	-	-

1	2	3	4	5	6	7	8	9	10	11	12
2766	Birmingham 291'61 Kish 1924: 198	ED III	12.4.1	Mound A	c.f. Mackay 1929, pl.52 no.44	Ci	-	-	-	-	*
12.5	Miniature stand: perforated										
2767	A 1925: 214 2702 M	ED III	12.5	Grave 147 (A)	Mackay 1929, pl.54 no.37 Moorey 1978, M 1, D11	Ai	-	-	-	-	*
13	<u>Painted ware</u> (body sherds)										
13.1	Painted ware: monochrome										
13.1	Monochrome: red-scarlet										
2768	A 1930: 190	ED I/II	13.1.1 8.17.3	Y sounding	Moorey 1978, M 2, C12	Ci	067	-	-	-	*
2769	A 1928 (ii)	ED I?	13.1.1 8.17.5	Y sounding	-	Aviii	019	-	-	-	*
13.1.3	Monochrome: purple-plum										
2770	A 1930: 196	ED I/II?	13.1.3	Y sounding	Moorey 1978, M 2, C12	Avi	029	-	18/29	-	-
2771	A 1929: 1359	ED I/II?	13.1.3 (waster)	Y sounding	-	Biii?	104	-	21/21	53/10	-
2772	A 1928 (i)	ED I/II?	13.1.3 8.17	-	-	Biii (Ur?)	-	-	-	-	-
13.2	Painted ware: polychrome										
13.2.1	Polychrome: red on white slip										
2773	A 1930: 208	ED I/II	13.2.1	Ingharra	Moorey 1978, M 2, A14	Other :2	105	-	21/23	53/11 53/12	*
2774	A 1930: 192	ED I/II	13.2.1	B/C trench	Moorey 1978, M 2, B08	Aii	042	-	-	-	*
13.2.3	Polychrome; red and black on white slip										
2775	A 1929: 135e	ED I?	13.2.3	Y sounding	Moorey 1978, M 2, C14	Bvi	094	-	-	-	*
2776	A 1929: 389	ED I/II	13.2.3	Y sounding	Moorey 1978, M 2, C12	Ai	047	-	19/25	-	*

1	2	3	4	5	6	7	8	9	10	11	12
2777	A 1924: 318c 1160	ED I/II?	13.2.3	-	-	Ciii	030	-	18/31	-	*
13.2.8 Polychrome: brown on white slip											
2778	A 1929: 134	ED I/II?	13.2.8	Ingharra	-	Other :2	095	-	21/11	51/35	*
14 Bases											
14.1 Flat bases											
14.1.2 Flat or slightly convex bases											
2779	A 1930: 248c	ED I/II?	14.1.2	Y sounding	Moorey 1978, M 2, C14	Ai?	051	-	19/38	-	*
2780	A 1930: 248d	ED I?	14.1.2	Y sounding	Moorey 1978, M 2, C14	Ei	010	-	-	-	*
14.1.5 Flat base: coarse ware											
2781	A 1930: 249	ED I?	14.1.5	Y sounding	Moorey 1978, M 2, C14	Dii	102	-	21/31	53/6	*
14.2 Round/ovoid base											
2782	A 1930: 194	Uruk?	14.2? 13.1.3	C trench	-	Gii	096	A103	21/15	-	-
14.3 Ring bases											
14.3.2 Ring base: low											
2783	A 1930: 189b	-	14.3.2 13.1.1	Y sounding	Moorey 1978, M 2, D05	Avii	011	-	-	-	*
15 Coarse ware body sherds											
2784	A 1930: 251a	-	15	Y sounding	Moorey 1978, M 2, C14	Li	-	-	-	-	-
2785	A 1930: 251b	-	15	Y sounding	Moorey 1978, M 2, C14	Li	-	-	-	-	-
16 Ceramic objects											
2786	A 1925: 335 2583	-	Clay cist	Grave 123	Mackay 1929, pl.54 no.51 Moorey 1978, M 1, C11	Aiii	-	-	-	-	*

1	2	3	4	5	6	7	8	9	10	11	12
JAMDAT NASR											
1	<u>Bowls</u>										
1.11	Bowl with perforated rim										
2787	A 1925: 423	-	1.11	-	Moorey 1978, M 3, B07	Avii	-	-	-	-	*
1.14	Bowl rim sherds										
1.14.8	Vertical-sided bowls										
2788	A 1926: 501a	ED I?	1.14.8.10 13.2.8	-	c.f. Mackay 1931, pl.67 no.21	Biii	083	-	-	-	*
2	<u>Jars</u>										
2.3	Large jars										
2.3.4	Large jars: ring base										
2789	BM 1935-1-12, 12	ED I?	2.3.4.2 8.11.3 13.1.1	-	c.f. Mackay 1931, pl.65 no.38	Ei	237	-	9/21	-	*
2790	BM 1930-12-13, 203 122903	-	2.3.4.2 13.2.10	-	c.f. Mackay 1931, pl.77 no.1 c f. Moorey 1978, M 3, B07	Aiv	-	-	-	-	*
2.4	<u>Jar rim sherds</u>										
2.4.2	Jar rim sherds: short neck										
2791	BM 1919-11-11, 573	ED I?	2.4.2.1 8.4.1.1 13.2.2	-	-	Biii	-	-	-	-	*
2792	A 1926: 502 (see also 2862)	Uruk?	2.4.2.2 8.6.1.1	-	c.f. Mynors forthcoming b, fig.1 no.20	Ci	064	-	-	-	*
2.4.5	Jar rims: bevelled rim										
2793	A 1926: 501b	-	2.4.5.1 8.12.1 13.2.8	-	c.f. Mackay 1931, pl.69 no.6	Bi	084	-	-	-	*

1	2	3	4	5	6	7	8	9	10	11	12
2794	A 1925: 378a	-	2.4.5.1 13.2.1	-	-	Avii	031	-	18/33	-	*
2.4.8 Jar sherd: flat rim											
2795	A 1981: 945c	-	2.4.8.7 13.1.1	(OFME)	-	Aiii	024	-	-	-	*
3 Bottles											
3.1 Bottles: bevelled rim											
2796	BM 1928-10-10, 502 121772	-	3.1 13.1.1 8.17	-	-	Cii	-	-	-	-	*
3.7 Bottle: multi-ribbed											
2797	BM 1928-10-10, 863 128534	-	3.7 8.17	-	-	Aiii	-	-	-	-	*
5 Spouted jars											
5.1 Spouted jar: flat base											
5.1.6 Spouted jar: flat base; tall bottle-neck											
2798	BM 1935-1-13, 425 137096 GN 1030	-	5.1.6	-	c.f. Mackay 1931, pl.63 no.18; pl.76 no.12	Avii	-	-	-	-	*
5.4 Spouted jars: pinched ring base											
5.4.1 Spouted jars: pinched ring base, flared rim											
2799	BM 1935-1-12, 121 134625 BM 825	ED I?	5.4.1	-	c.f. Delougaz 1952, pl.38; pl.180 c.f. Woolley 1955, 162	Avii	-	-	-	-	*
8 Body sherds (jars)											
8.5 Incised decoration											
8.5.2 Incised decoration: cross-hatched											
2800	A 1925: 403a	ED I?	8.5.2	-	-	Bii	077	A236	-	-	*

1	2	3	4	5	6	7	8	9	10	11	12
13 Painted ware (body sherds)											
13.1 Painted ware: monochrome											
13.1.1 Monochrome: red-scarlet											
2801	Birmingham 865'53	-	13.1.1 8.4.1.2 8.4.2.4 8.6.2.1	-	-	Di	315	-	-	-	*
13.1.3 Monochrome: purple-plum											
2802	A 1926: 498	-	13.1.3 8.4.1.5 8.17	-	c.f. Mackay 1931, pl.64 no.10 c.f. Moorey 1978, M 3, B10	Avii	008	-	19/10	-	*
13.2 Painted ware: polychrome											
13.2.1 Polychrome: red on white slip											
2803	A 1981: 946a	ED I?	13.2.1	-	c.f. Mackay 1931, pl.68 no.8	Eii	058	A232	19/31	51/26	*
2804	A 1981: 946b	ED I?	13.1.1 8.1	-	-	Eiii	046	-	-	-	*
13.2.2 Polychrome: black on white slip											
2805	A 1925: 389	-	13.2.2	-	-	Bii	-	-	-	-	*
13.2.3 Polychrome: red and black on white slip											
2806	Birmingham 866'53	ED I?	13.2.3	-	c.f. Mackay 1931, pl.69 no.12 c.f. Moorey 1978, M 3, B07	Ei	316	-	-	-	*
2807	A 1925: 376	ED I?	13.2.3 8.4.2.1 8.17	-	c.f. Mackay 1931, pl.77 no.4	Aviii	037	-	-	-	*
2808	A 1926: 499a	ED I?	13.2.3 8.4.2.1 8.17	-	c.f. Mackay 1931, pl.79 no.1	Eii	044	A220	-	-	*
13.2.8 Polychrome: brown on white slip											
2809	A 1926: 501b	ED I?	13.2.8	-	-	Biii	082	-	-	-	*

1	2	3	4	5	6	7	8	9	10	11	12
2810	A 1926: 501	-	13.2.8 8.4.1.1 8.6	-	c.f. Mackay 1931, pl.69 no.2; pl.77 no.2	-	-	-	-	-	*
2811	A 1925: 388	-	13.2.8 8.4.1.2	-	c.f. Mackay 1931, pl.68 no.13	Biv	085	-	20/38	-	*
13.2.11 Polychrome: red and purple on white slip											
2812	A 1926: 500b 3431	-	13.2.11 8.17	-	Mackay 1931, pl.68 no.15	Avii	-	-	-	-	*
2813	A 1925: 358a	ED I?	13.2.11 8.17	-	-	Ei	028	A221	-	-	*
13 Painted ware: body sherds (other)											
2814	A 1981: 944a	ED I?	13.2.3 8.4.1.1	-	c.f. Postgate and Moon 1982, 114-115, fig.5 no.11; 116-117, fig. 6 no.1	Aviii	-	-	-	-	*
2815	A 1926: 501	ED I?	13.2.3 8.4.1.1	-	c.f. Postgate and Moon 1982, 114-115, fig.5 no.11; 116-117, fig. 6 no.1	Biii	-	-	-	-	-
14 Bases											
14.1 Flat bases											
14.1.2 Flat or slightly convex base											
2816	A 1981: 941	-	14.1.2 13.1.1	-	c.f. Mackay 1931, pl.77 no.1	Avii	-	-	-	-	*
14.3 Ring bases											
14.3.4 Ring base: added											
2817	A 1981: 941g	-	14.3.4 13.1.1	-	c.f. Mackay 1931, pl.77 no.3	Ai	001	-	18/35	51/17	*

1	2	3	4	5	6	7	8	9	10	11	12	
TELL AL WILAYEH												
3	<u>Bottles</u>											
3.4	Bottle: carinated shoulder and square body											
2818	Iraq Museum	no acc.	ED III?	3.4	-	c.f. Delougaz 1952, pl.165; B703.560 Al Kaissi and Mynors forthcoming, fig.2 no.10	Aii	238	-	7/31	-	*
TELL AGRAB												
8	<u>Body sherds (jars)</u>											
8.6	Impressed decoration											
8.6.7	Impressed decoration: horizontal row of lozenge shapes											
2819	Iraq Museum	no acc.	ED I?	8.6.7	-	Al Kaissi and Mynors forthcoming,	Bi	238	-	6/29	-	*
2820	(see also no. 2284)			8.10		fig.3 no.23	Bi	242	-	6/33	-	-
8.9	Reserve-slipped decoration											
8.9.1	Diagonal reserve slip											
2821	Iraq Museum	no acc.	ED I?	8.9.1	-	Al Kaissi and Mynors forthcoming, fig.3 no.22	Aiv	240	-	6/35	-	*
9	<u>Upright handled jar sherd</u>											
2822	Iraq Museum		ED II/III	9? 8.5.2	-	Al Kaissi and Mynors forthcoming, fig.3 no.25	Aiv	239	-	-	-	*
14	<u>Bases</u>											
14.1	Flat base											
2823	Iraq Museum	no acc.	ED?	14.1.2? 1.4?	-	Al Kaissi and Mynors forthcoming, fig.3 no.24	-	243	-	6/31	-	*

1	2	3	4	5	6	7	8	9	10	11	12	
KHAFAJAH												
2	<u>Jars</u>											
2.2	Medium jar											
2.2.2	Medium jar: flat base											
2824	Iraq Museum	no acc.	ED?	2.2.2 8.20	-	c.f Delougaz 1952, pl.182; C536.270 Al Kaissi and Mynors forthcoming, fig.3 no.22	Aiv	245	-	6/36	-	*
2.3	Large jar											
2.3	Large jar: ring base (Scarlet ware)											
2825	BM 1933-5-1, 13	123293	ED I	2.3.4 13.2.3	-	Delougaz 1952, pl.62	Avii	-	-	-	-	-
10	Stemmed dishes											
10.8	Stemmed dish base											
10.8.2	Stemmed dish base: ribbed											
2826	BM 1962-6-2, 4	136396	-	10.8.2	-	-	Aii (kh)	244	-	10/33	-	*
13	<u>Painted ware</u>											
13.1	Painted ware: monochrome											
13.1.1	Monochrome: red-scarlet (Scarlet ware)											
2827	Iraq Museum	no acc.	ED I?	13.1.1	-	Al Kaissi and Mynors forthcoming, tb.1; tb. 2a; tb.2b	Biv	247	-	6/38	-	-
13.2	Painted ware: polychrome											
13.2.4	Polychrome: purple on white slip											
2828	Iraq Museum	no acc.	ED I?	13.2.4	-	Al Kaissi and Mynors forthcoming, fig.3 no.20	Av	246	-	-	-	*

1	2	3	4	5	6	7	8	9	10	11	12	
TELL ASMAR												
2	<u>Jars</u>											
2.2	Medium jars											
2.2.1	Medium jar: round base (multi-lugged)											
2829	Iraq Museum	no acc.	ED III?	2.2.1 8.4.2.5	-	c.f. Delougaz 1952, pl.188; C665.543a Al Kaissi and Mynors forthcoming, fig.3 no.19	Aiv	248	-	7/14	-	*
ABU QASIM												
2	<u>Jars</u>											
2.4	Jar rim sherds											
2.4.1	Jar rim sherd: hole-mouthed											
2830	Iraq Museum	no acc.	ED I?	2.4.1.7 8.4.3 13.2.3	-	Al Kaissi and Mynors forthcoming, fig.4 no.26	Eii?	249	-	-	-	*
8	<u>Body sherds</u> (jars)											
8.12	Decorated ribs: notched/nicked											
8.12.1	Single rib with notched/nicked decoration (Scarlet ware)											
2831	Iraq Museum	no acc.	ED I/II?	8.12.1 13.2.3	-	Al Kaissi and Mynors forthcoming, fig.4 no.27	Ei	-	-	-	-	*
13	Painted ware											
13.2	Painted ware: polychrome											
13.2.3	Polychrome: red and black on white slip (Scarlet ware)											
2832	Iraq Museum	no acc.	ED I/II?	13.2.3	-	Al Kaissi and Mynors forthcoming, fig.4 no.28	Eii	250	-	8/7	-	*

1	2	3	4	5	6	7	8	9	10	11	12	
KHEIT QASIM												
1	<u>Bowls</u>											
1.3	Goblet											
2833	Iraq Museum	V14 19	ED ?	1.1? 1.3.1?	-	Al Kaissi and Mynors forthcoming, fig.4 no.30	Gi	252	-	7/35	-	*
1.4	Cup											
1.4.1	Cup: flat base											
2834	Iraq Museum	V11	Akkad.?	1.4.1	-	c.f Delougaz 1952, pl.148; B052.200a Al Kaissi and Mynors forthcoming, fig.4 no.29	Bvi	251	-	-	-	*
1.14	Bowl sherds											
1.14.1	Bowl sherd: fine; plain rim (monochrome: red)											
2835	KQ 1		-	1.14.1	-		Bii?	218	KQ1	-	-	-
2	<u>Jars</u>											
2.4	Jar rim sherds											
2.4.5	Jar rim sherds: bevelled rim											
2836	KQ 2		ED I	2.4.5.4	-		Bi	219	KQ2	-	-	-
2837	KQ 3		ED I	2.4.5.4 13.1.1	-		Aiv	217	KQ3	-	-	-
13	Painted ware											
13.2	Painted ware: polychrome											
13.2.3	Polychrome: red and black on white slip (Scarlet ware)											
2838	KQ 4		ED I	13.2.3	-		Ci	220	KQ4	-	-	-

1	2	3	4	5	6	7	8	9	10	11	12	
HALAWA												
2	Jars											
2.4	Jar rim sherds											
2.4.2	Jar rim sherd: short neck (polychrome: purple on white slip)											
2839	Iraq Museum	no acc.	J.N.	2.4.2.4	-	Al Kaissi and Mynors forthcoming,	Gi	252	-	7/35	-	*
2840				8.4.1.1 13.2.4		fig.4 no.32 c.f Mackay 1931, pl.79 no.1	Ci	254	-	7/25	-	-
TELL AL RUBEIDHEH												
2841	RB A		L. Uruk	8	-	Mynors forthcoming b, fabric Ai	Mvi	602	-	17/14	53/15	-
2842	RB 40/14		L. Uruk	8.6.8	-	Mynors forthcoming b, fabric Aii	Mvii	603	-	17/15	53/16	*
2843	RB 40/4		L. Uruk	2.4.5.3 8.13.5	-	Mynors forthcoming b, fabric Aiii	Mviii	604	-	-	53/17	*
2844	RB 41/16		L. Uruk	2.4.8.6 2.5.2	-	Mynors forthcoming b, fabric Aiv	Mv	605	-	17/24	53/18	*
2845	RB 510		L. Uruk	2.1 8.18.1	-	Mynors forthcoming b, fabric Av	Bi	610	-	-	53/19	*
2846	RB 41/4		L. Uruk	2.4.2.5	-	Mynors forthcoming b, fabric Bi	Aii	606	-	-	53/20 53/21	*
2847	RB 33		L. Uruk	2.4.2.11 8.3.3	-	Mynors forthcoming b, fabric Bii	Biii	611	-	17/26	-	*
2848	RB 302		L. Uruk	14.3.4	-	Mynors forthcoming b, fabric Bii	Bii Bii	609 612	-	-	-	*
2849	RB 2FS.21		L. Uruk	BRB (min.)	-	Mynors forthcoming b, fabric Bii	Diii	607	-	-	53/22	*
-	RB			BRB		Mynors forthcoming b, fabric Diii		623 624	-	-	50/8 53/28	-
2850	RB 49		L. Uruk	1.14.3.6	-	Mynors forthcoming b, fabric Bii	Dii Diii	608 613	-	17/31	-	*
2851	RB 1003/3		L. Uruk	2.4.5.2? 8.6.4	-	Mynors forthcoming b, fabric Bii	Ai	614	-	-	-	*

1	2	3	4	5	6	7	8	9	10	11	12
2852	RB 41	L. Uruk	1 1.16.4	-	Mynors forthcoming b, fabric Bii	Hvii	616	-	-	-	*
2853	RB 506	L. Uruk	2.4.2.2 8.4.1.1 8.6.1 13.1.1	-	Mynors forthcoming b, fabric Ci	Ai	617	-	-	-	*
2854	RB 301/42	L. Uruk	2.4.6.4? 8.6.1	-	Mynors forthcoming b, fabric Ci	Hvi	615	-	18/4	53/23	*
2855	RB 40/9	L. Uruk	1.14.1.1	-	Mynors forthcoming b, fabric Cii	Ci Ci	618 619	-	17/35	53/24	* -
2856	RB 302	L. Uruk	2.4.6.6 8.6.1	-	Mynors forthcoming b, fabric Di	Div	620	-	-	53/15 53/26	-
2857	RB 41/13	L. Uruk	2.4.2.6 13.1.1	-	Mynors forthcoming b, fabric Dii	Di	621	-	17/38	-	*
2858	RB 303/12	L. Uruk	1.14.7.6	-	Mynors forthcoming b, fabric Eii	Eii	622	-	17/17	53/27	*
2859	RB 40(A)	L. Uruk	8.5.4	-	Mynors forthcoming b, fabric Ei	Bv Bv	625 626	RB40A	-	53/29	*
2860	RB 40/6	L. Uruk	2.4.6.4? 8.6.2	-	Mynors forthcoming b, fabric Eii	Ei Ei	627 628	RB4016	17/19	53/31 53/32	* -
2861	RB 40/8	L. Uruk	2.4.2.2 8.6.1.1	-	Mynors forthcoming b, fabric Eii	Ei	-	-	-	-	*
2862	RB 102	L. Uruk	1.17	-	Mynors forthcoming b, fabric Fi	Ciii	-	-	-	-	*
2863	RB 304/11	L. Uruk	1.14.6.1	-	Mynors forthcoming b, fabric Fi	Ciii	629	-	-	53/33	*
2864	RB 315/1	L. Uruk	1.14.8.5	-	Mynors forthcoming b, fabric Fii	Ciii	-	-	-	-	*
2865	RB 506/2	L. Uruk	1.1	-	Mynors forthcoming b, fabric Fii	Ciii	-	-	-	-	*
2866	RB 51/1	L. Uruk	8.4.2.1	-	Mynors forthcoming b, fabric Gi	Civ	-	-	-	-	*
2867	RB 42	L. Uruk	2.4.8.2	-	Mynors forthcoming b, fabric Gi	Civ	-	-	-	-	*
2868	RB 309	L. Uruk	2.4.2.2 8.6.2	-	Mynors forthcoming b, fabric Gi	Civ	-	-	-	-	*

1	2	3	4	5	6	7	8	9	10	11	12
2869	RB 41/11	L. Uruk	13.2.2	-	Mynors forthcoming b, fabric Hi	Cii	-	-	-	-	*
2870	RB 40/2	L. Uruk	2.4.5.1 8.4.1.1 13.1.1	-	Mynors forthcoming b, fabric Hii	Cii	630	RB402	-	53/34	*

SUWARI

2 Jars

2.4 Jar rim sherds

2.4.6 Jar sherds: collar/band rim

2871	Suwari	ED III?	2.4.6.5	Surface	-	Bi	256	-	-	-	-
------	--------	---------	---------	---------	---	----	-----	---	---	---	---

5 Spouted Jars

5.7 Spouted jar sherds: spouts

5.7.2 Long spout

2872	Suwari	ED	5.7.2	Surface	-	Aii	255	-	-	-	-
------	--------	----	-------	---------	---	-----	-----	---	---	---	---

TELL AL 'USIYEH

2873	Al'U A	ED	-	-	-	Ei?	257	AL UI	-	50/9	-
2874	Al'U B	ED	-	-	-	Ei	258	AL UB	-	-	-
2875	Al'U C	ED	-	-	-	Ei?	259	-	-	-	-
2876	Al'U D	ED	-	-	-	Eii	260	-	-	-	-

UMM AN NAR

2 Jars

2.4 Jar rim sherds

2.4.2 Jar rim sherd: short neck

2877	UN 1979: 472	ED	2.4.2.8	-	-	Aiii	565	-	-	-	-
------	--------------	----	---------	---	---	------	-----	---	---	---	---

1	2	3	4	5	6	7	8	9	10	11	12
2.4.3 Jar rim sherd: long neck											
2878	UN 1979: 421	-	2.4.3.2	-	-	Bvi?	589	-	-	-	-
2879	UN 1979: 478	-	2.4.3.2	-	-	Ei	-	-	-	-	-
2880	UN 1979: 512	-	2.4.3.7	-	-	Ei	-	UN512	-	-	-
2.4.4 Jar sherd: rolled rim											
2881	UN 1979: 248	-	2.4.4.1	-	-	Bvi	587	-	-	-	-
2.4.5 Jar sherds: bevelled rim											
2882	UN 1979: 453	-	2.4.5.2	-	-	Bi	584	UN453	-	-	-
2883	UN 1979: 350	-	2.4.5.4	-	Mynors 1983, 385, fig.4 no.2	Bi	586	-	-	-	*
2884	UN 1979: 366	-	2.4.5.4	-	-	Bvi	590	-	-	-	-
2885	UN 1979: 398	-	2.4.5.7	-	Mynors 1983, 385, fig.4 no.3	Aiii	569	UN398	-	50/10	*
2886	UN 1979: 149	-	2.4.5.9	-	-	Ei	577	UN149	-	-	-
2.4.6 Jar sherds: collar/band rim											
2887	UN 1979: 177	-	2.4.6.2	-	-	Bvi	592	UN177	-	50/11	-
2888	UN 1979: 372	-	2.4.6.2	-	-	Ei	578	UN372	-	-	-
2889	UN 1979: 403	-	2.4.6.2	-	Mynors 1983, 385, fig.4 no.7	Aiii	568	UN403	-	-	*
2890	UN 1979: 127	-	2.4.6.3	-	Mynors 1983, 385, fig.4 no.4	Gii	579	UN127	-	-	*
2891	UN 1979: 243	-	2.4.6.6	-	-	Bi	582	UN243	-	-	-
2892	UN 1979: 244	-	2.4.6.7	-	-	Fi	583	-	-	-	-
2893	UN 1979: 332	-	2.4.6.8	-	-	Gii	581	-	-	-	-

1	2	3	4	5	6	7	8	9	10	11	12
2.4.7 Jar sherds: collar/band rim; dished/grooved											
2894	UN 1979: 370	-	2.4.7.1 13.1.1	-	Mynors 1983, 385, fig.4 no.6	Aiii	566	UN370	-	-	*
2895	UN 1979: 152	-	2.4.7.2	-	Mynors 1983, 385, fig.4 no.1	Gi Gi	571 588	UN152	-	-	*
2896	UN 1979: 331	-	2.4.7.4	-	Mynors 1983, 385, fig.4 no.5	Bvi	591	-	-	-	*
2897	UN 1979: 371	-	2.4.7.4	-	-	Gii	580	-	-	-	-
2898	UN 1979: 454	-	2.4.7.4	-	-	Ei	570	UN454	-	-	-
2899	UN 1979: 517	-	2.4.7.4	-	-	Ii	567	UN517	-	-	-
2900	UN 1979: 414	-	2.4.7.4	-	-	Bi	585	-	-	-	-
<u>Others</u>											
1 Bowl											
2901	UN 1979	-	-	-	c.f. de Cardi, Collier and Doe 1976, 132-133, fig.19 no.140 Mynors 1983, 385, fig.5 no.1	UNi UNi	574 575	UNOW	-	-	*
2 Jar rim sherd (polychrome: red and brown on pink slip)											
2902	UN 1979	-	-	-	c.f. Frifelt 1975, fig.18c,d,f	UNii	573	UN1979	-	-	-
3 Body sherds (jars)											
2903	UN 1979	-	-	-	-	Aiv	564	-	18/9	-	-
2904	UN 1979	-	-	-	-	UNiii	593	-	-	-	-
2905	UN 1979	-	-	-	-	-	572	UNLL	-	50/14 50/15	-
2906	UN 1979	-	-	-	-	UNi	576	UN352	-	-	-
4 Imitation steatite ware											
2907	UN 1929: 469	-	-	-	c.f. Frifelt 1975, fig. 18e	UNiv UNiv	596 597	-	-	-	-

1	2	3	4	5	6	7	8	9	10	11	12
2908	UN 1979: 247	-	-	-	-	UNv	598	-	-	50/13	-
5	<u>Painted ware (jars)</u>										
	Polychrome: black on pink slip										
2909	UN 1979: 208	-	-	-	Mynors 1983, 385, fig.5	UNiii	594	UN208	-	50/12	*
2910	UN 1979: 501	-	-	-	-	UNiii	595	-	-	-	-
2911	UN 1979: 145	-	-	-	-	UNiii	-	UN145	-	-	-
	<u>HILI</u>										
	<u>Jar rim: Imitation steatite ware with incised decoration</u>										
2912	H. Grey	-	-	-	Mynors 1983, 385, fig.5 c.f. de Cardi, Collier and Doe 1976, 118-121; fig.15	UNvi	599	HGREY	-	-	*
	<u>Painted ware: polychrome; black on white slip</u>										
2913	H. 2	-	-	-	-	Ei	600	H2JN	18/17	-	-
2914	H. 152	-	-	-	-	Ei	601	-	-	-	-
	<u>Base: ring base; perforated, polychrome; black on pink slip</u>										
2915	H. 54	-	-	-	c.f. Moorey 1978, M 2, D05; 1930: 198a Mynors 1983, 385, fig.5	Aiv	-	H54	18/13	-	*

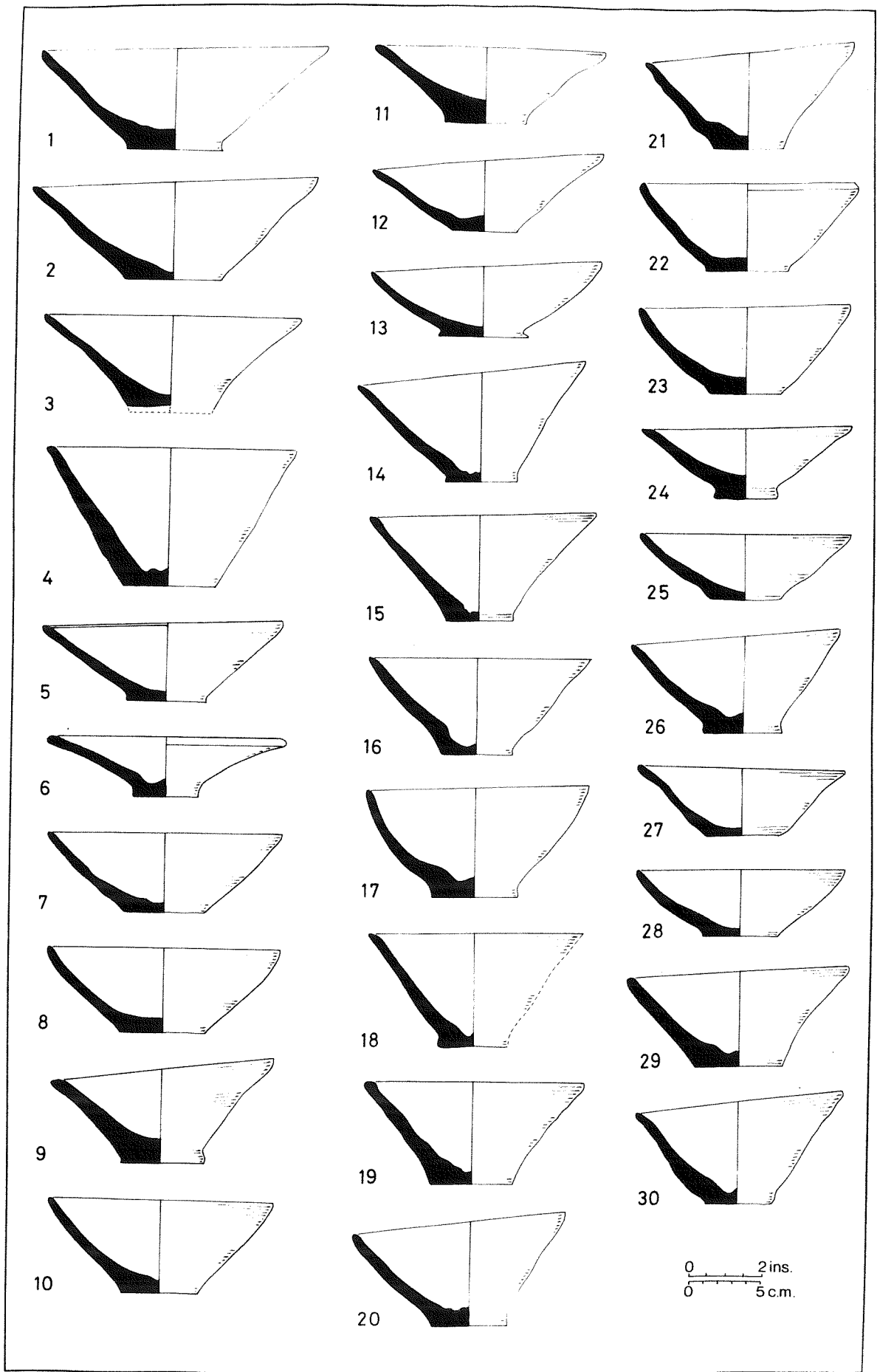

Fig. 8.13 Ur: Pottery samples 0001-0030. Type 1.1; Conical bowls ($\frac{1}{4}$)

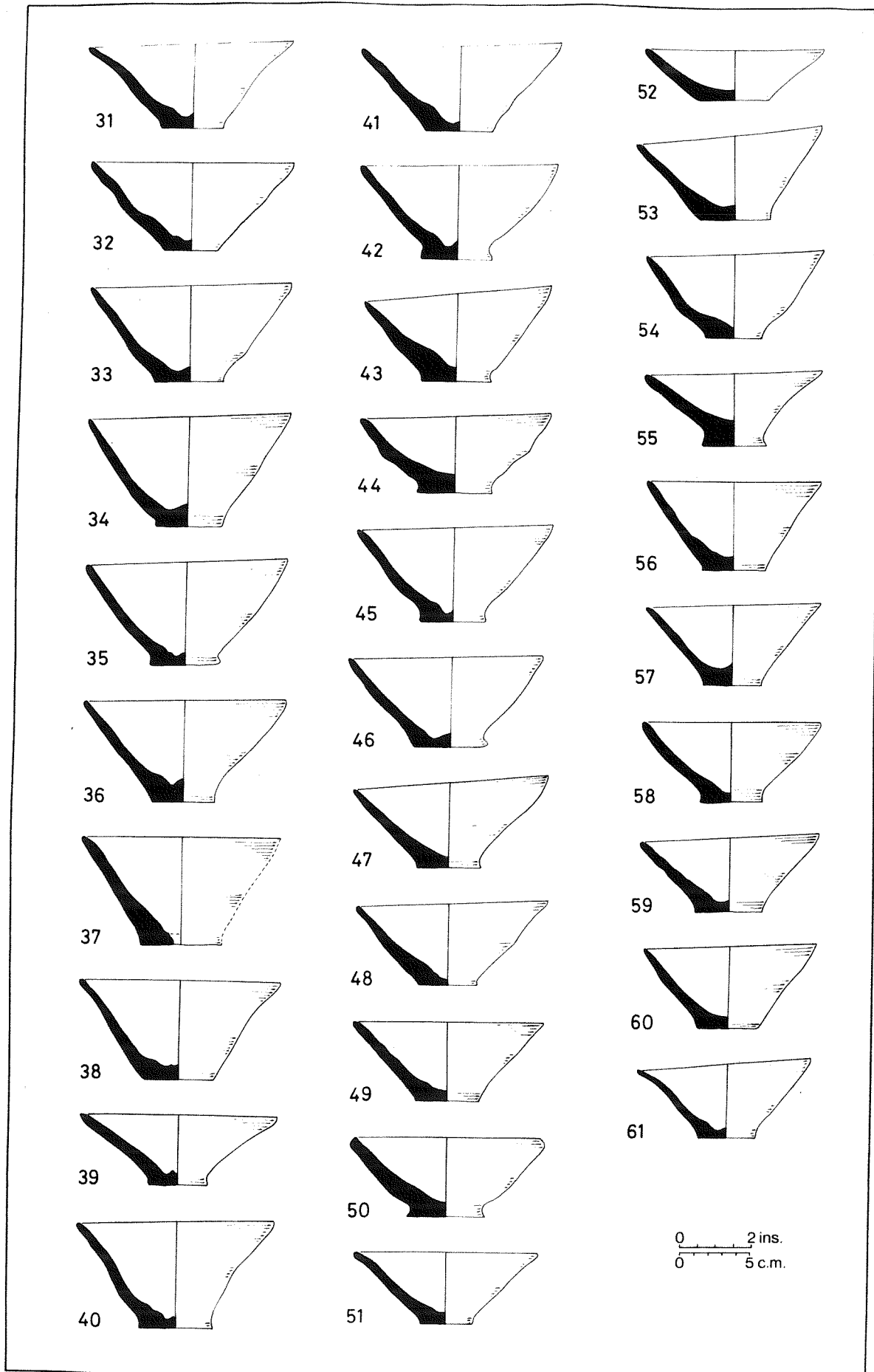

Fig. 8.14 Ur: Pottery samples 0031-0061. Type 1.1; Conical bowls ($\frac{1}{4}$)

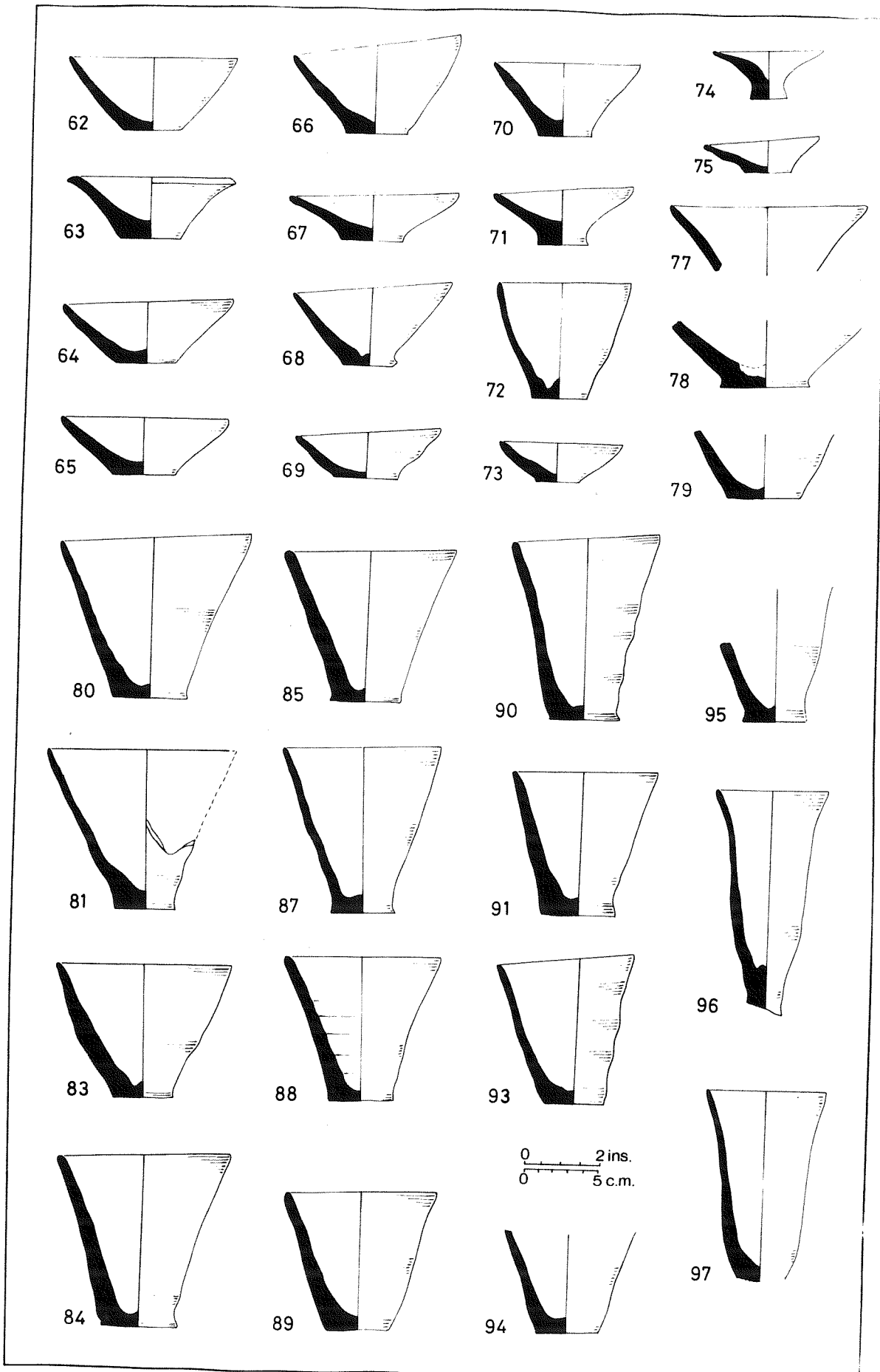

Fig. 8.15 Ur: Pottery samples 0062-0097. Type 1.1; Conical bowls and Type 1.3; Goblets ($\frac{1}{4}$)

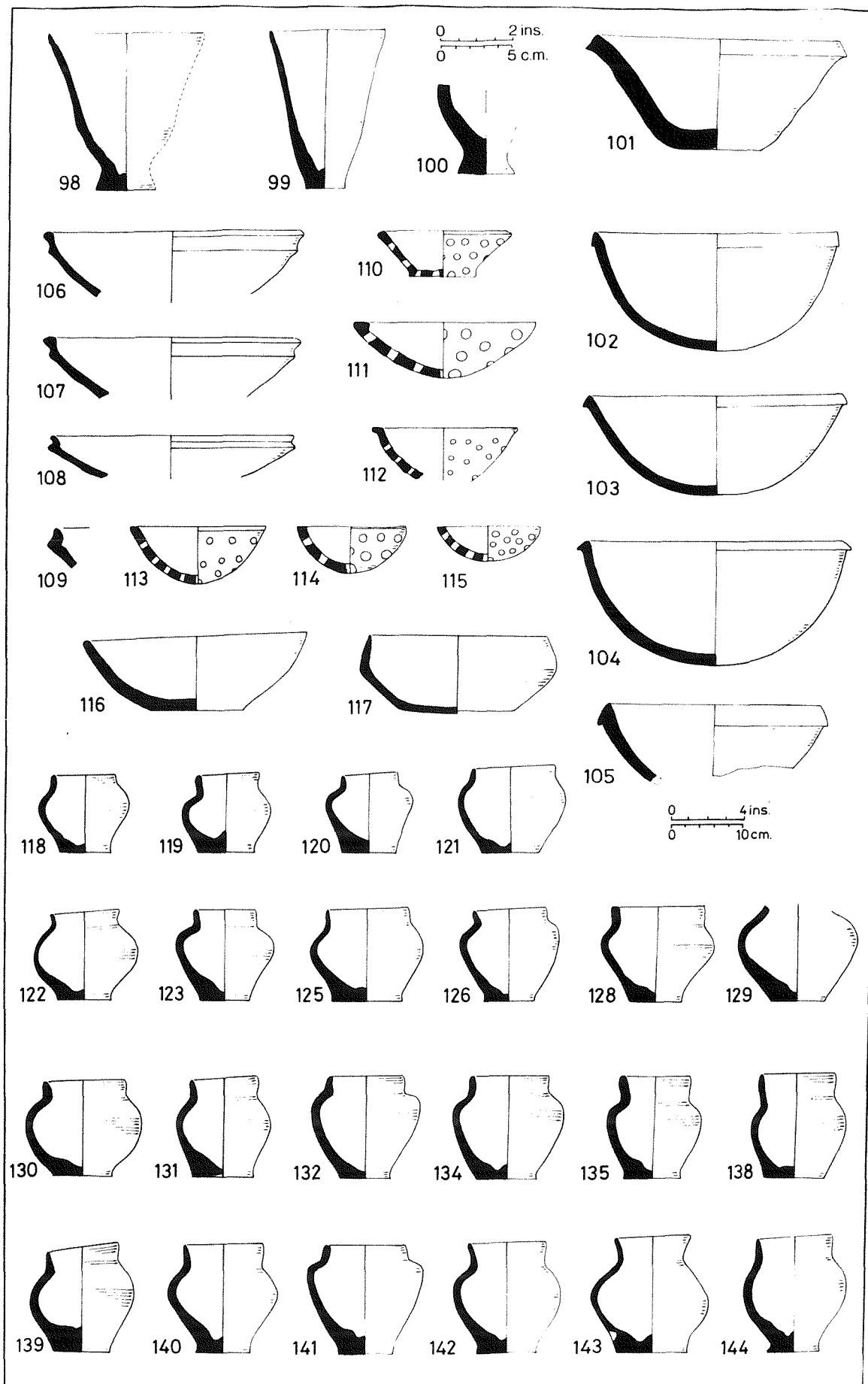

Fig. 8.16 Ur: Pottery samples 0098-0144. Types 1.3; BRB; 1.6; 1.8; 1.9 and 2.1 ($\frac{1}{4}$)

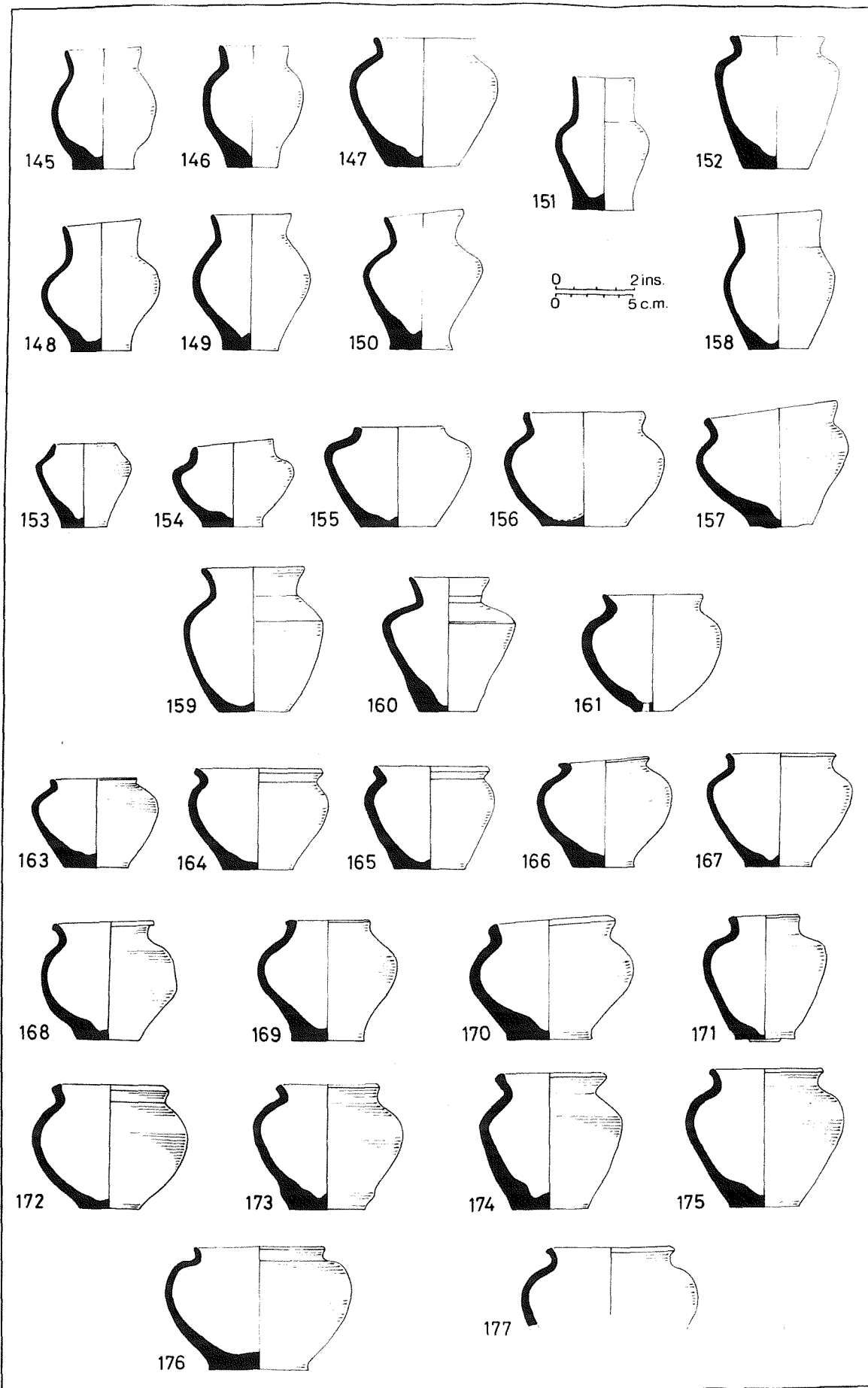

Fig. 8.17 Ur: Pottery samples 0145-0177. Type 2.1.1; Small jars: flat base (string-cut) ($\frac{1}{2}$)

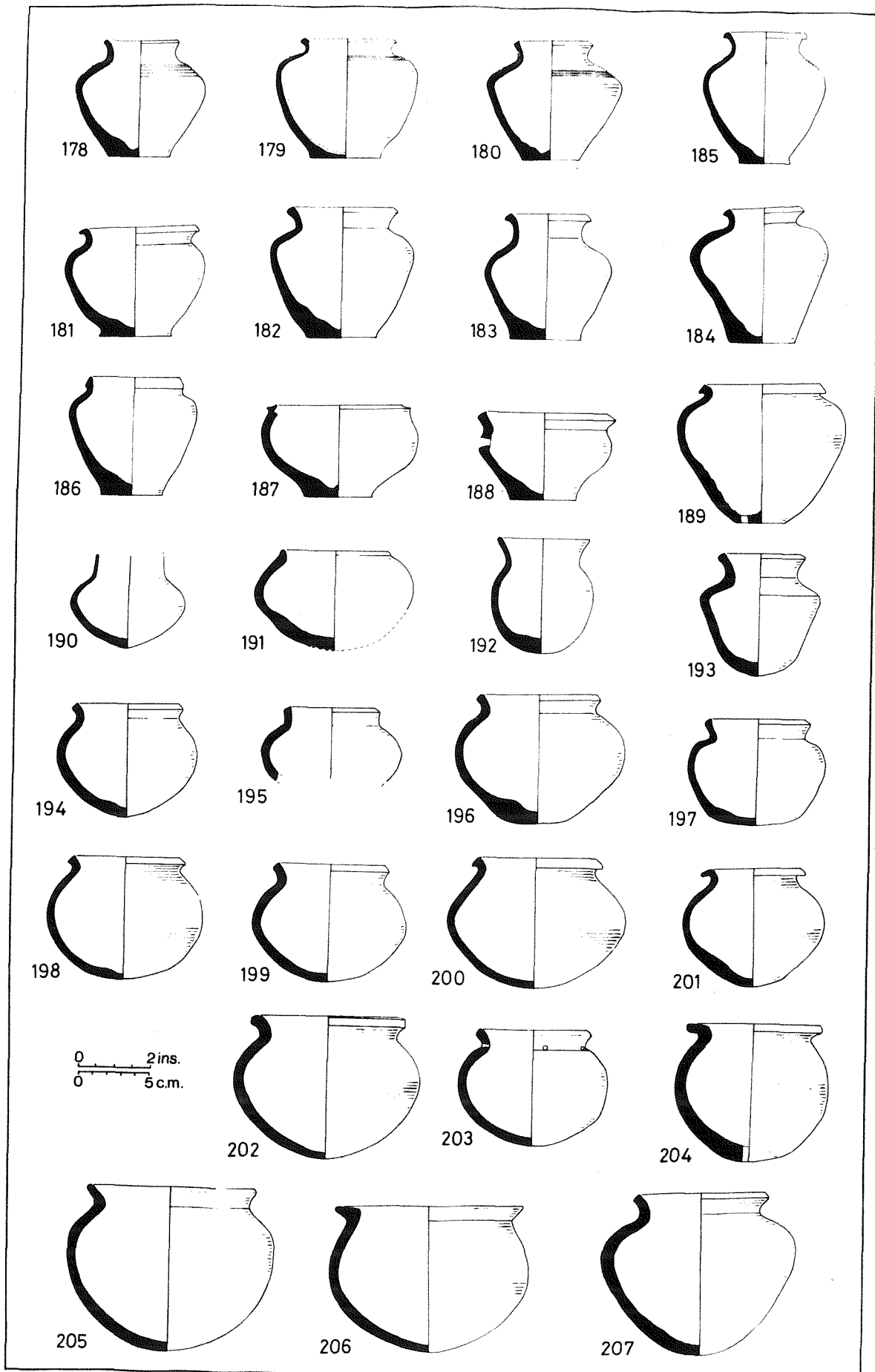

Fig. 8.18 Ur: Pottery samples 0178-0207. Type 2.1.1; Small jars: flat base and Type 2.1.2; Small jars: round base ($\frac{1}{4}$)

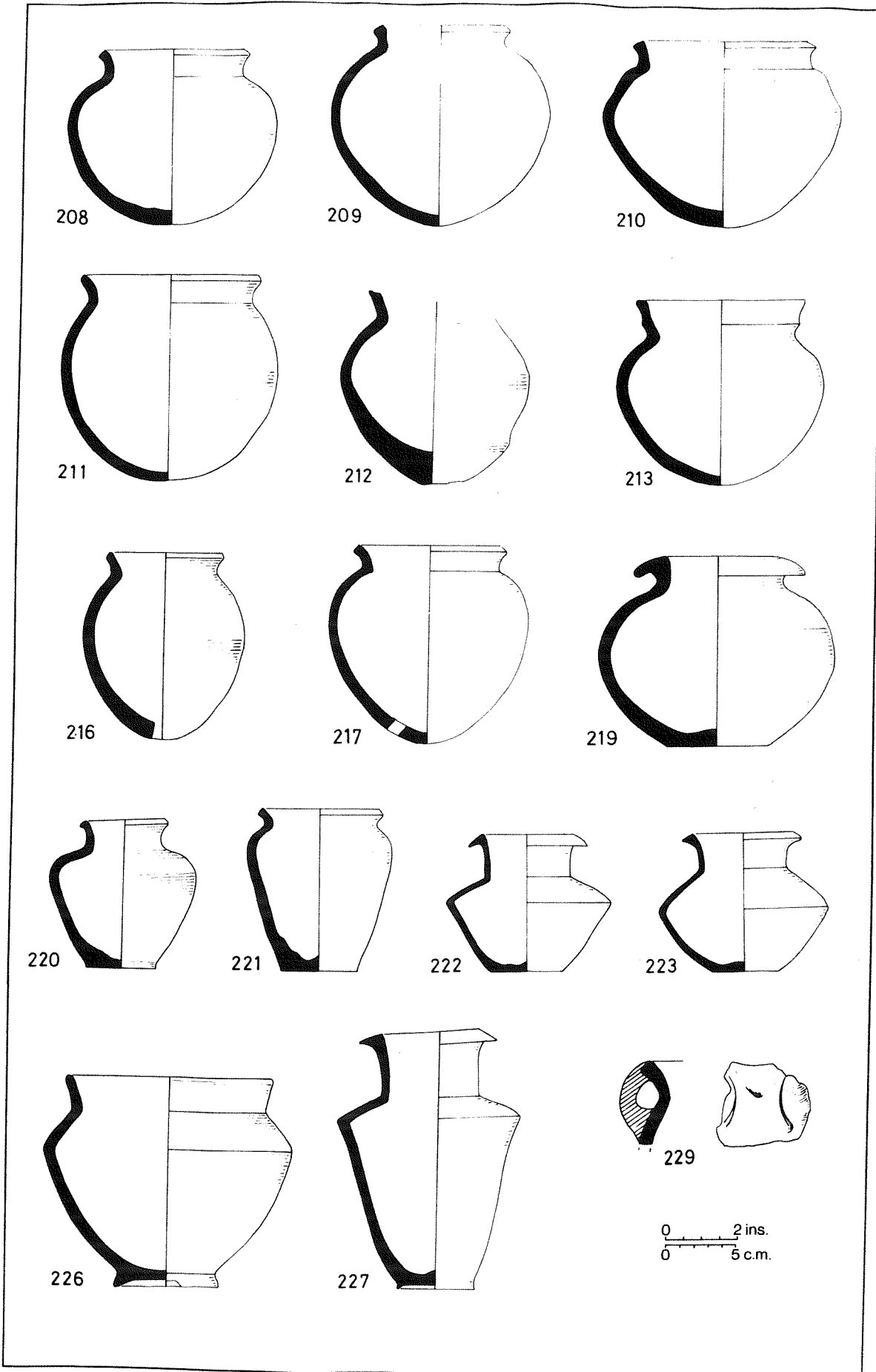

Fig. 8.19 Ur: Pottery samples 0208-0229. Type 2.2; Medium jars and Type 2.1/8.18.1; Uruk strap-handled jar (¼)

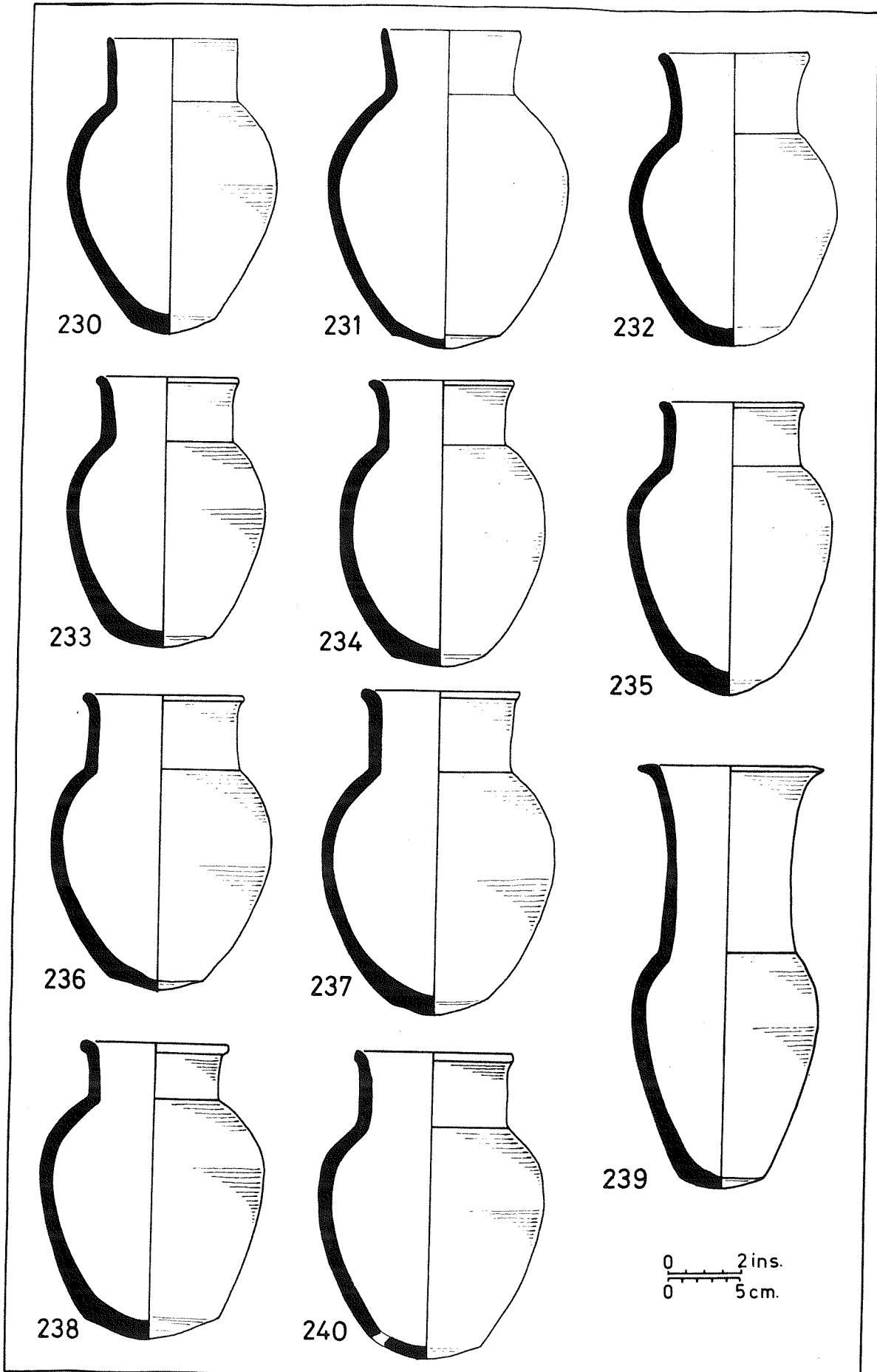

Fig. 8.20 Ur: Pottery samples 0230-0240. Type 2.3.2; Large jars: concave base

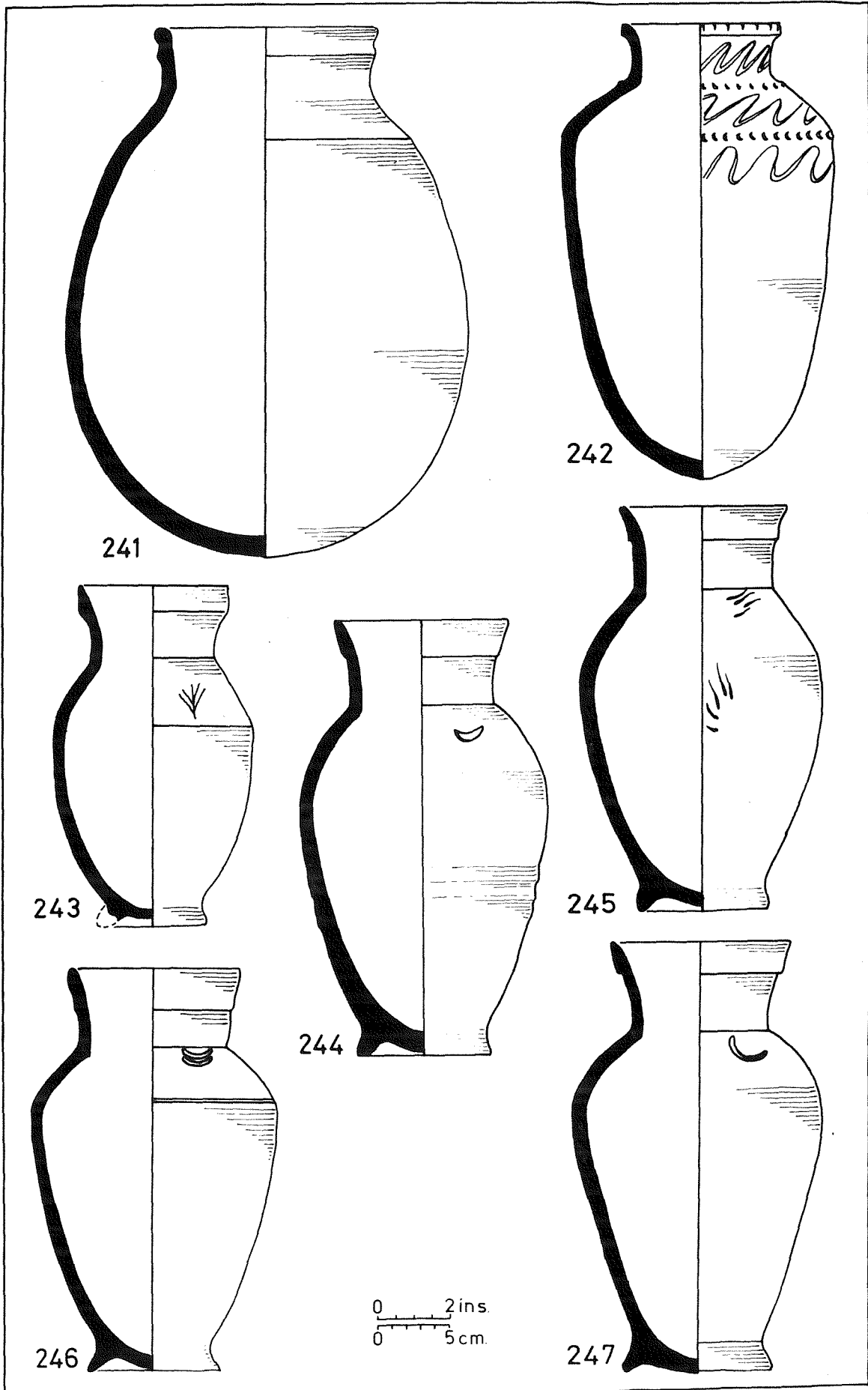

Fig. 8.21 Ur: Pottery samples 0241-0247. Type 2.3.3; Large jars: round base and Type 2.3.4; Large jars: ring base ($\frac{1}{4}$)

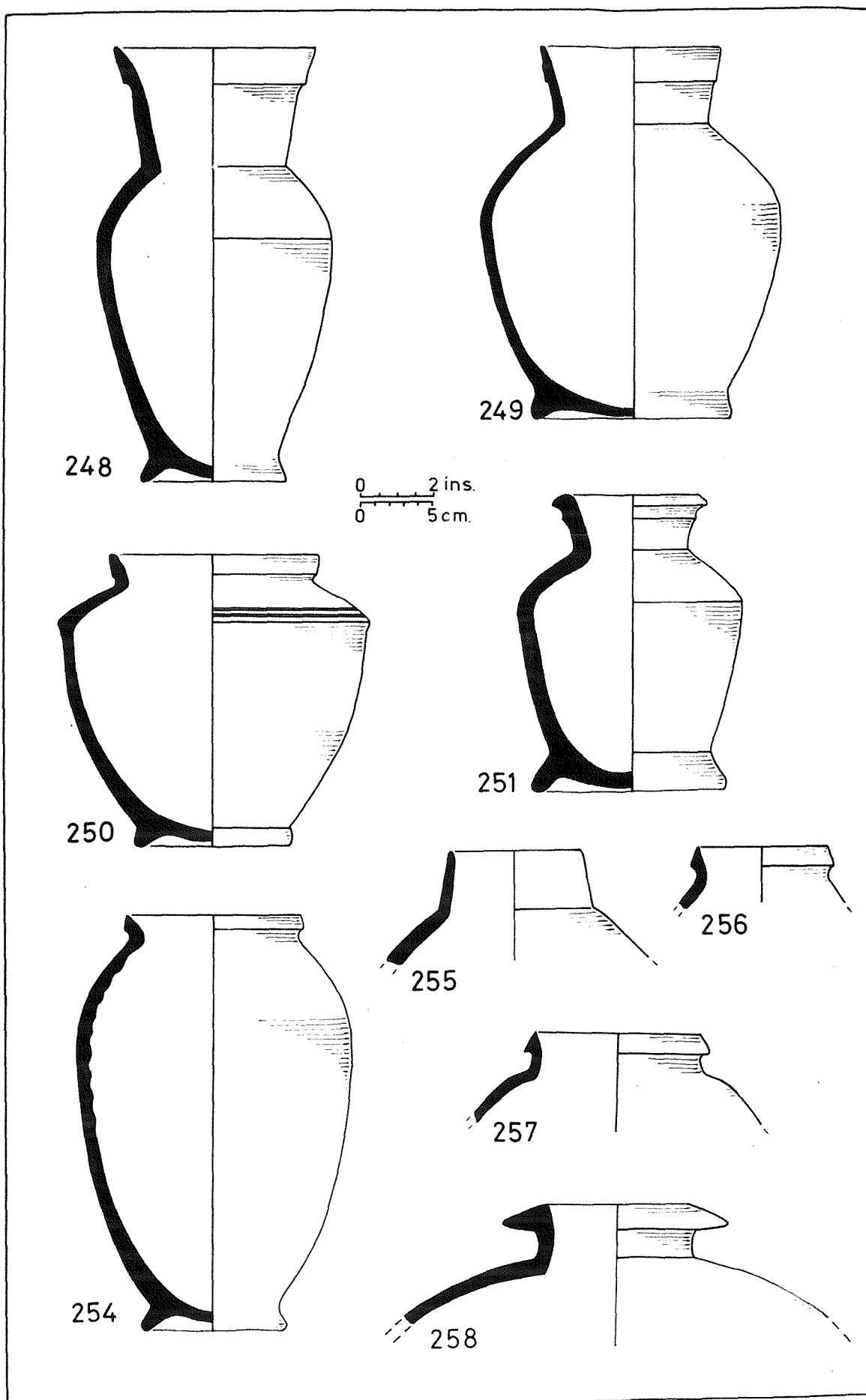

Fig. 8.22 Ur: Pottery samples 0248-0258. Type 2.3.4; 2.4.3 and 2.4.5; Large jars and jar sherds ($\frac{1}{2}$)

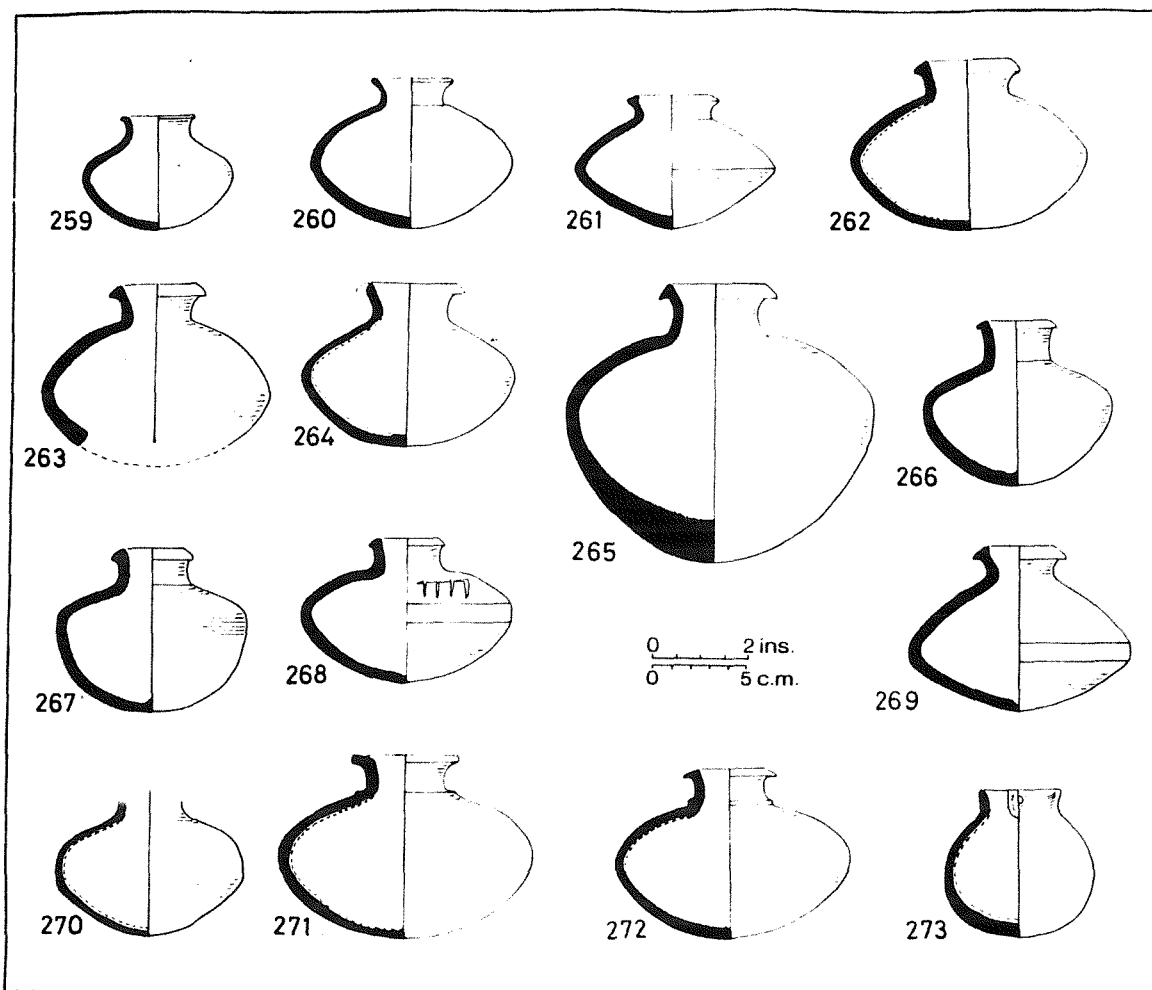

Fig. 8.23 Ur: Pottery samples 0259-0273. Type 3; Bottles ($\frac{1}{4}$)

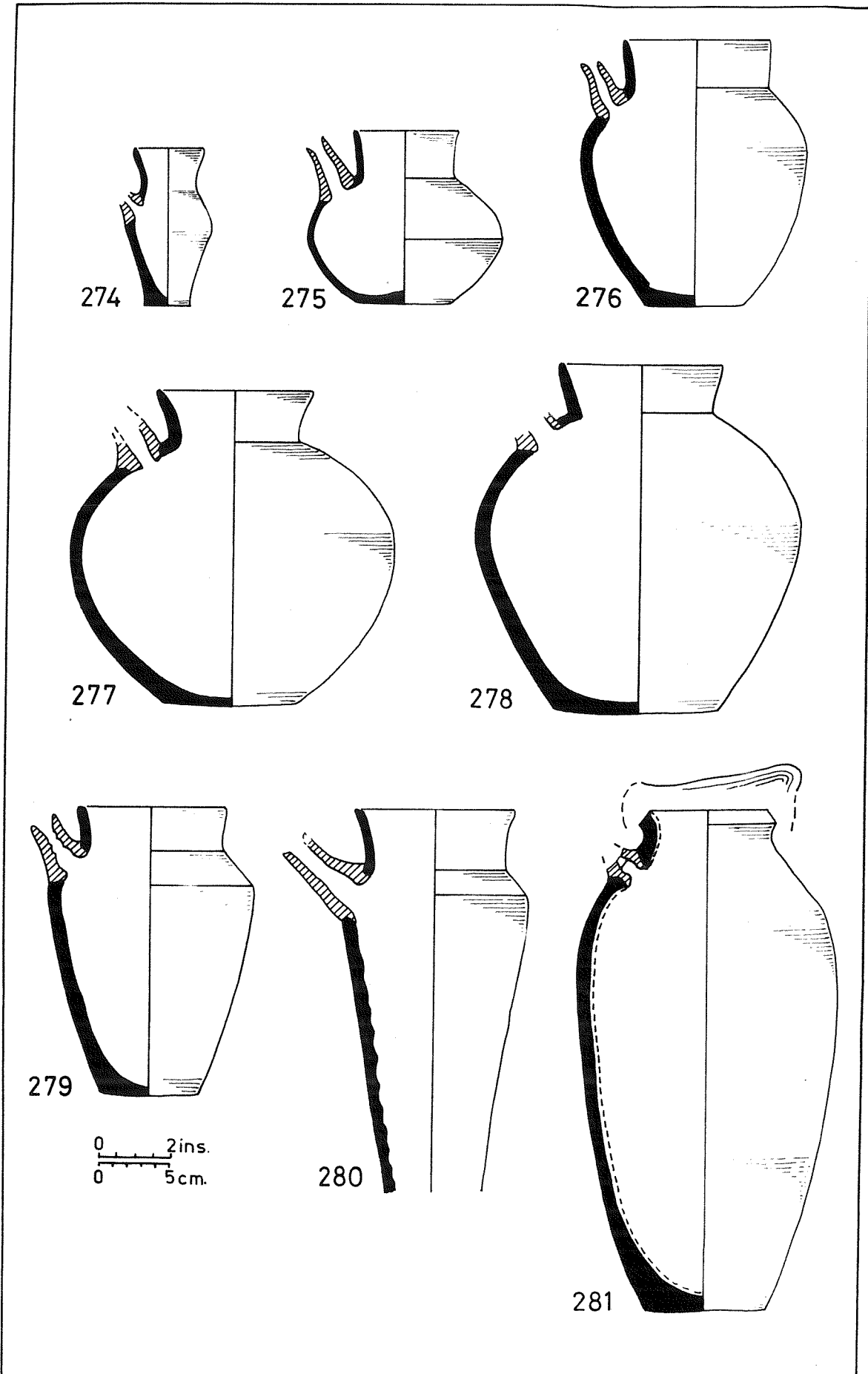

Fig. 8.24 Ur: Pottery samples 0274-0281. Type 5.1; Spouted jars ($\frac{1}{4}$)

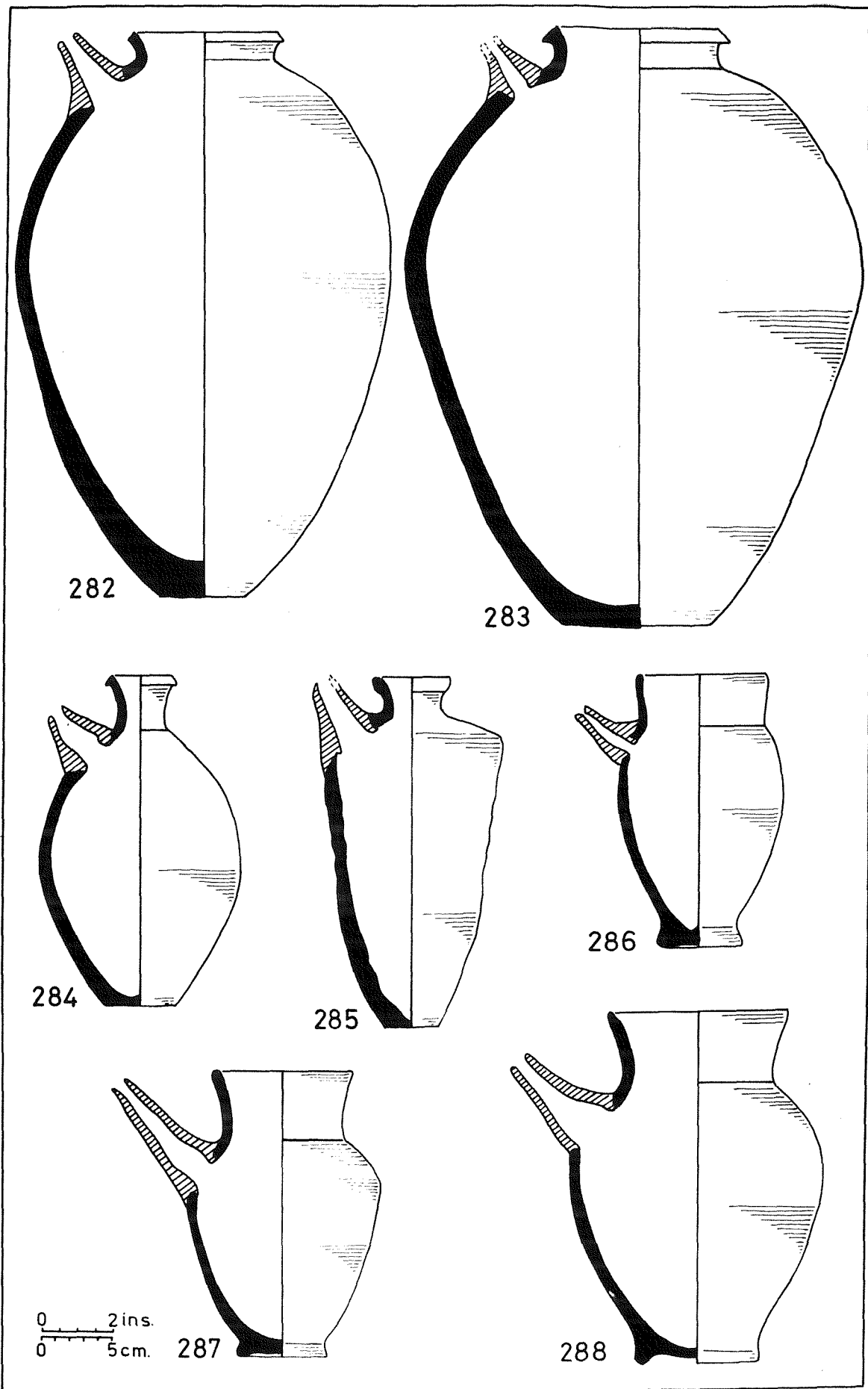

Fig. 8.25 Ur: Pottery samples 0282-0288. Type 5.1; Spouted jars ($\frac{1}{2}$)

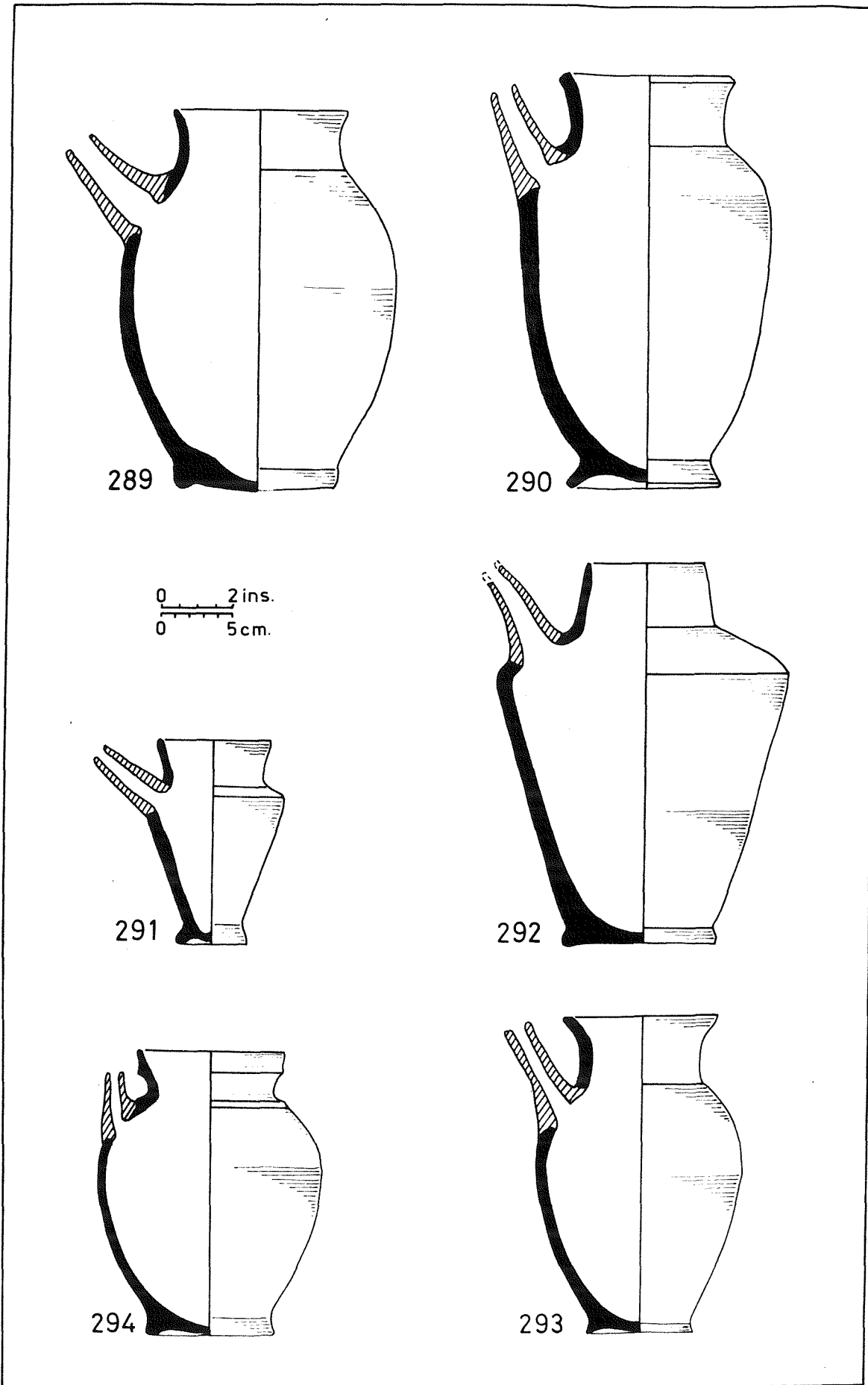

Fig. 8.26 Ur: Pottery samples 0289-0293. Type 5.1; Spouted jars ($\frac{1}{4}$)

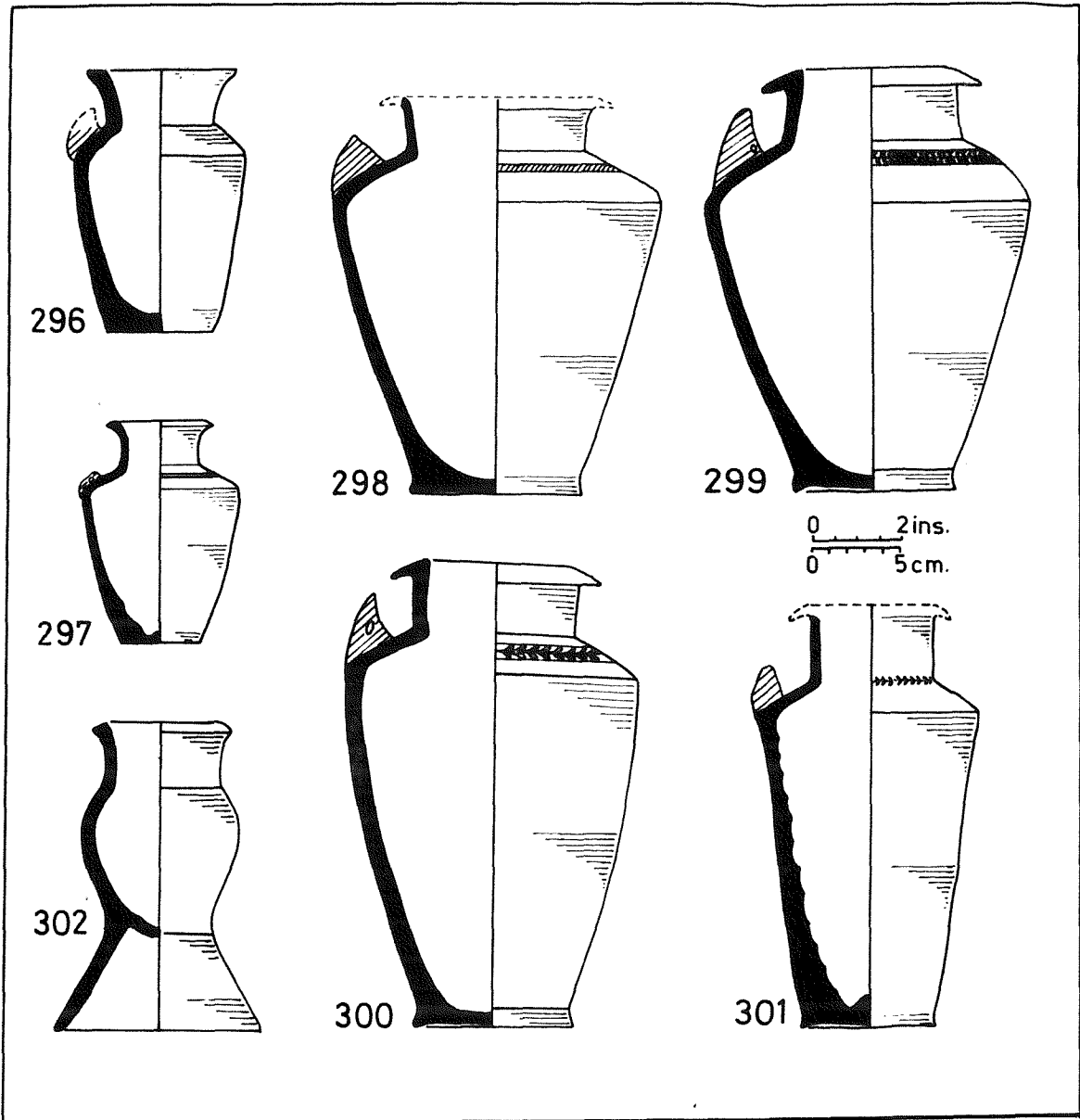

Fig. 8.27 Ur: Pottery samples 0296-0301. Type 6; wing-lugged jars
($\frac{1}{2}$)

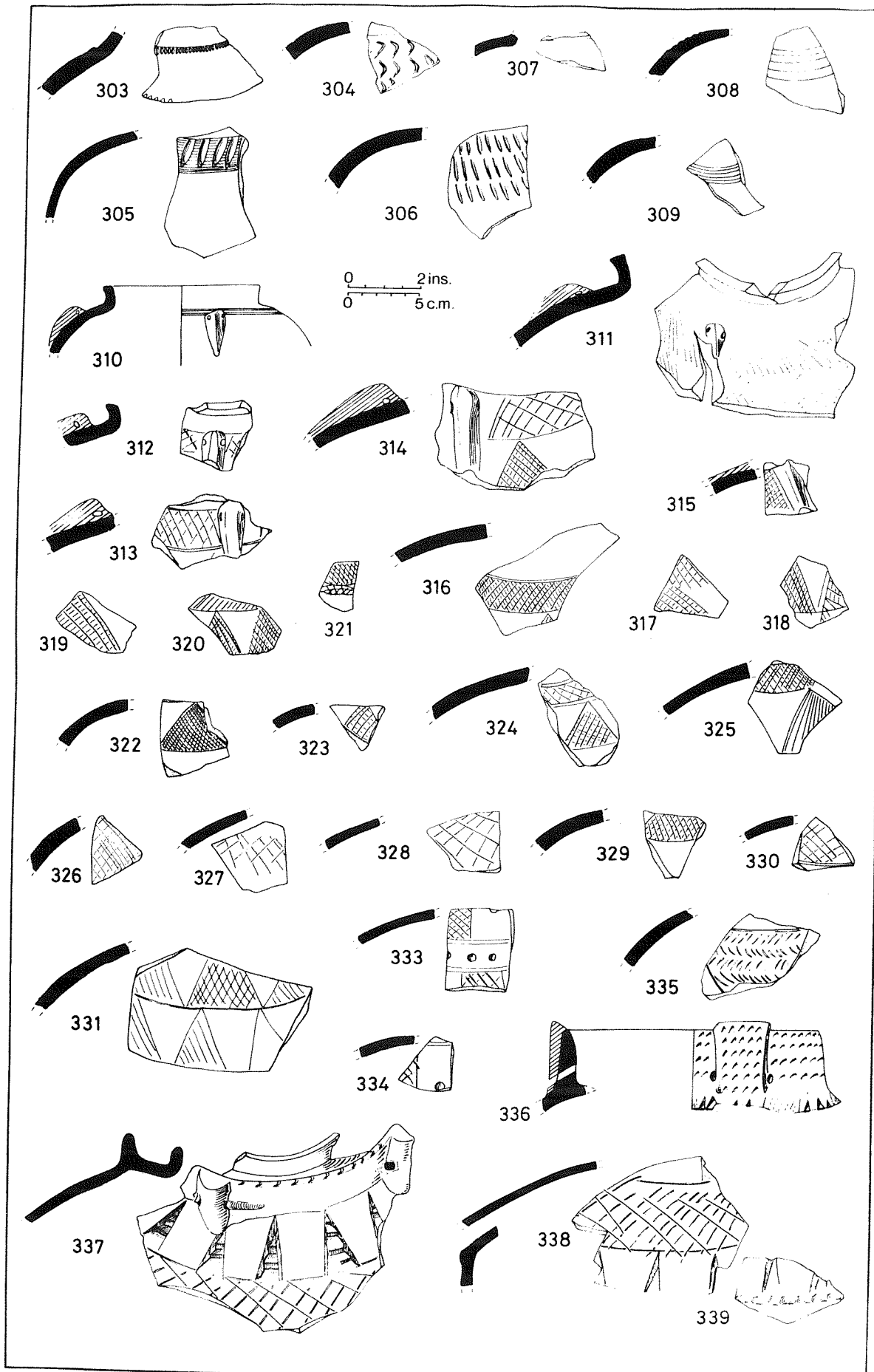

Fig. 8.28 Ur: Pottery samples 0303-0339. Type 8; L.Uruk/E.ED I decorated jar sherds ($\frac{1}{4}$)

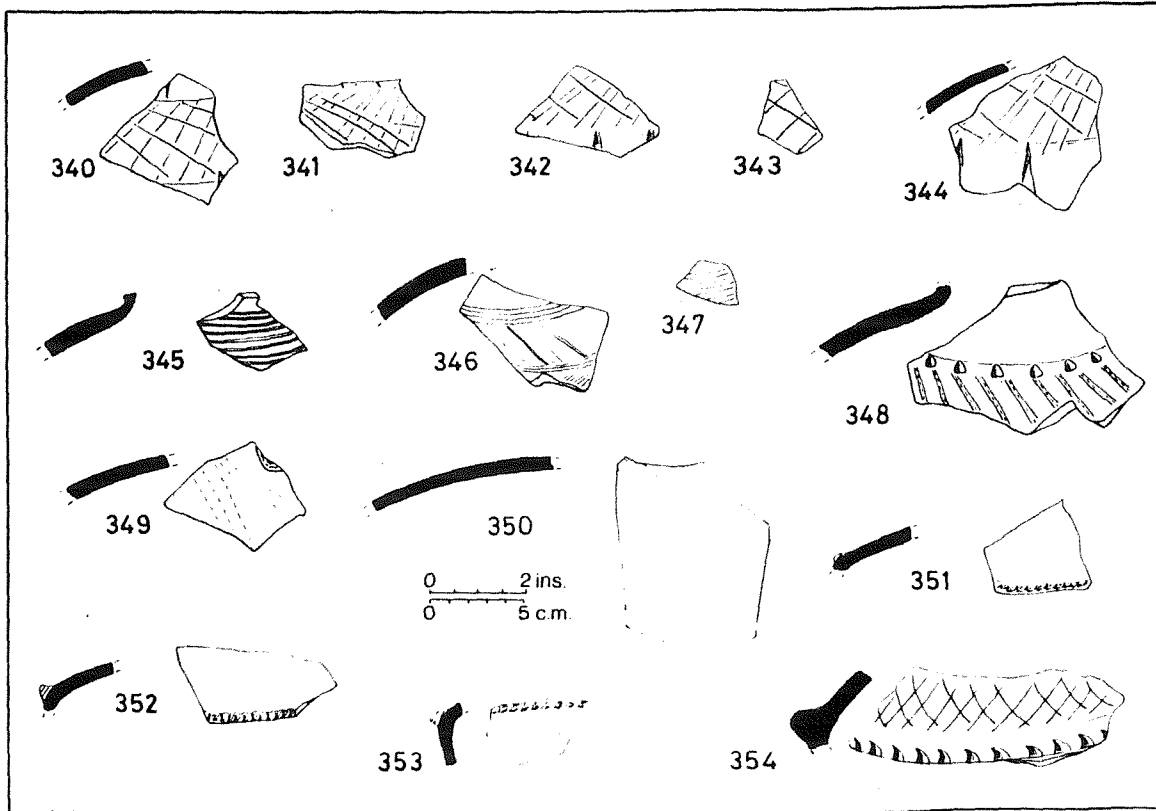

Fig. 8.29 Ur: Pottery samples 0340-0353. Type 8; ED I decorated jar sherds. Pottery sample 0354. Type 9; upright-handled jar sherd? ($\frac{1}{4}$)

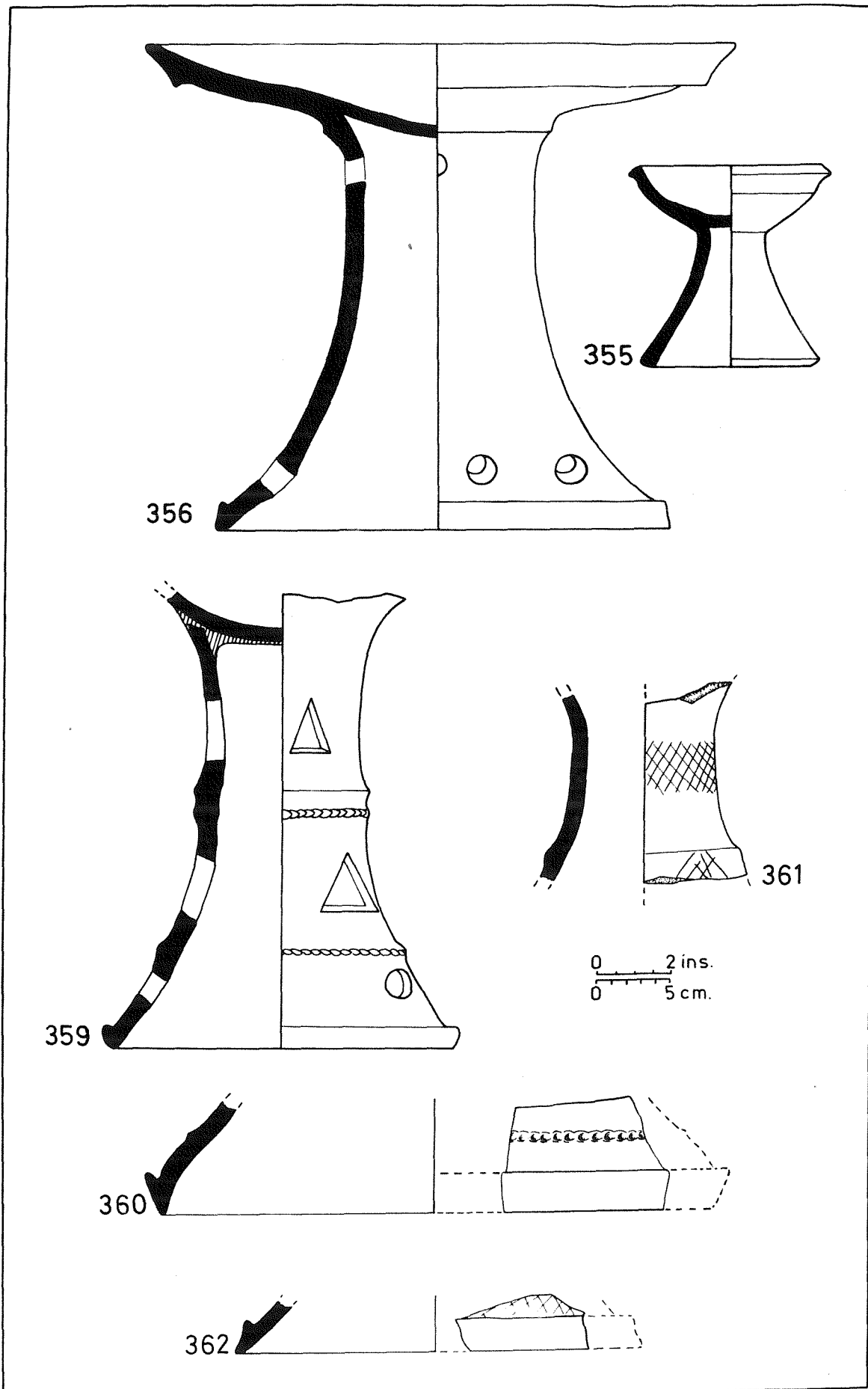

Fig. 8.30 Ur: Pottery samples 0356-0362. Type 10; Stemmed dishes (4)

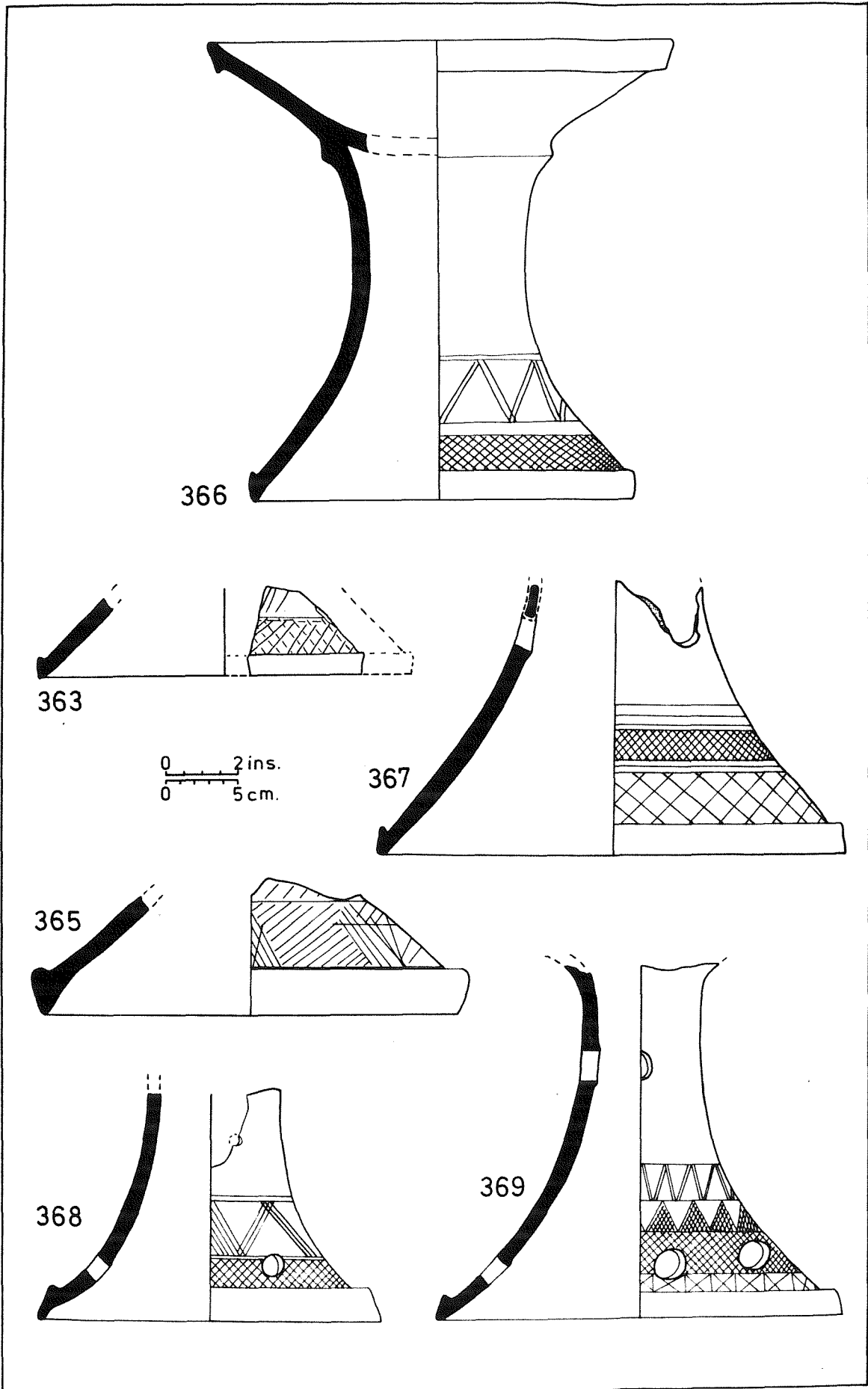

Fig. 8.31 Ur: Pottery samples 0366-0369. Type 10; Stemmed dishes ($\frac{1}{4}$)

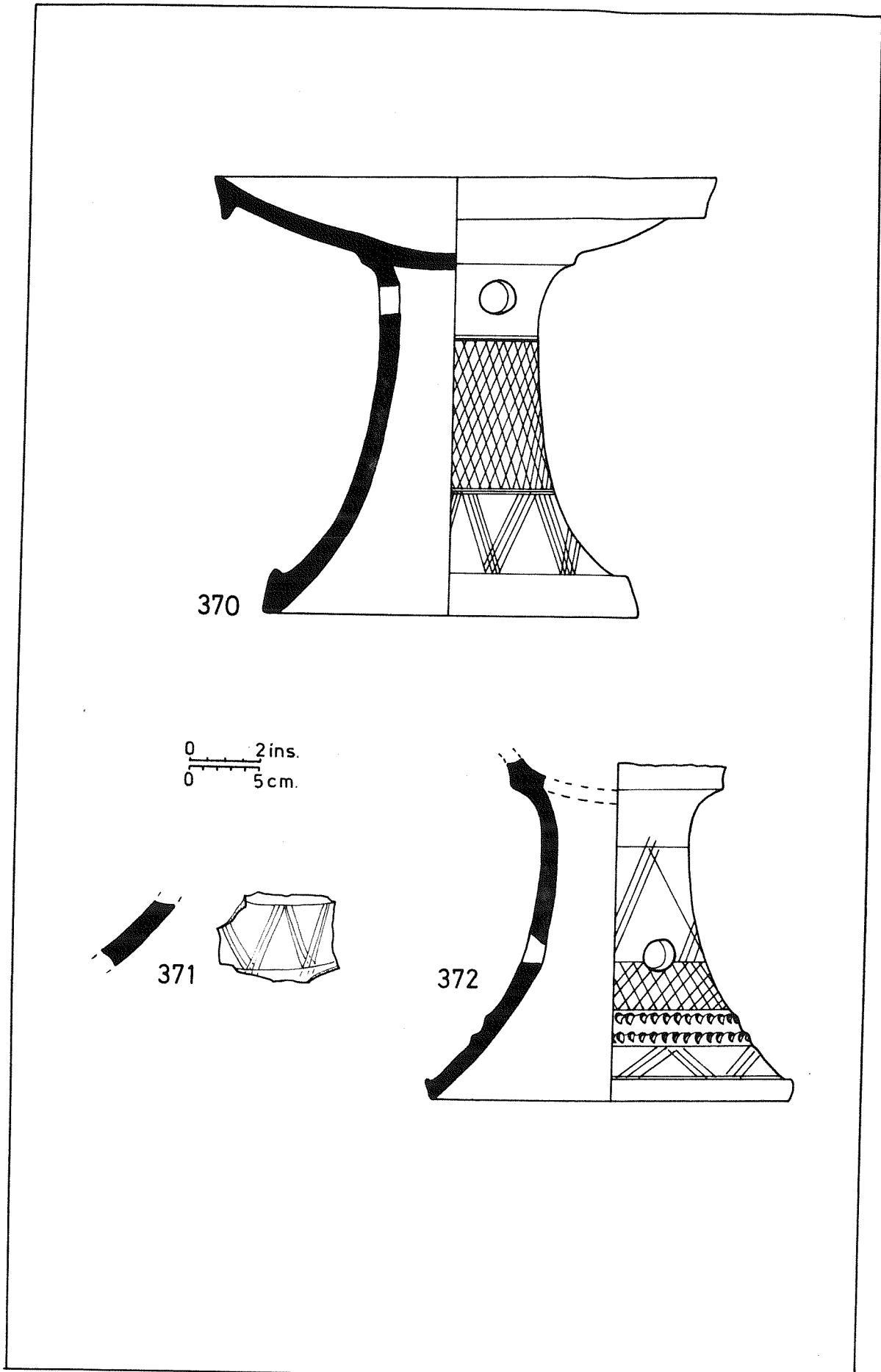

Fig. 8.32 Ur: Pottery samples 0370-0372. Type 10; Stemmed dishes ($\frac{1}{4}$)

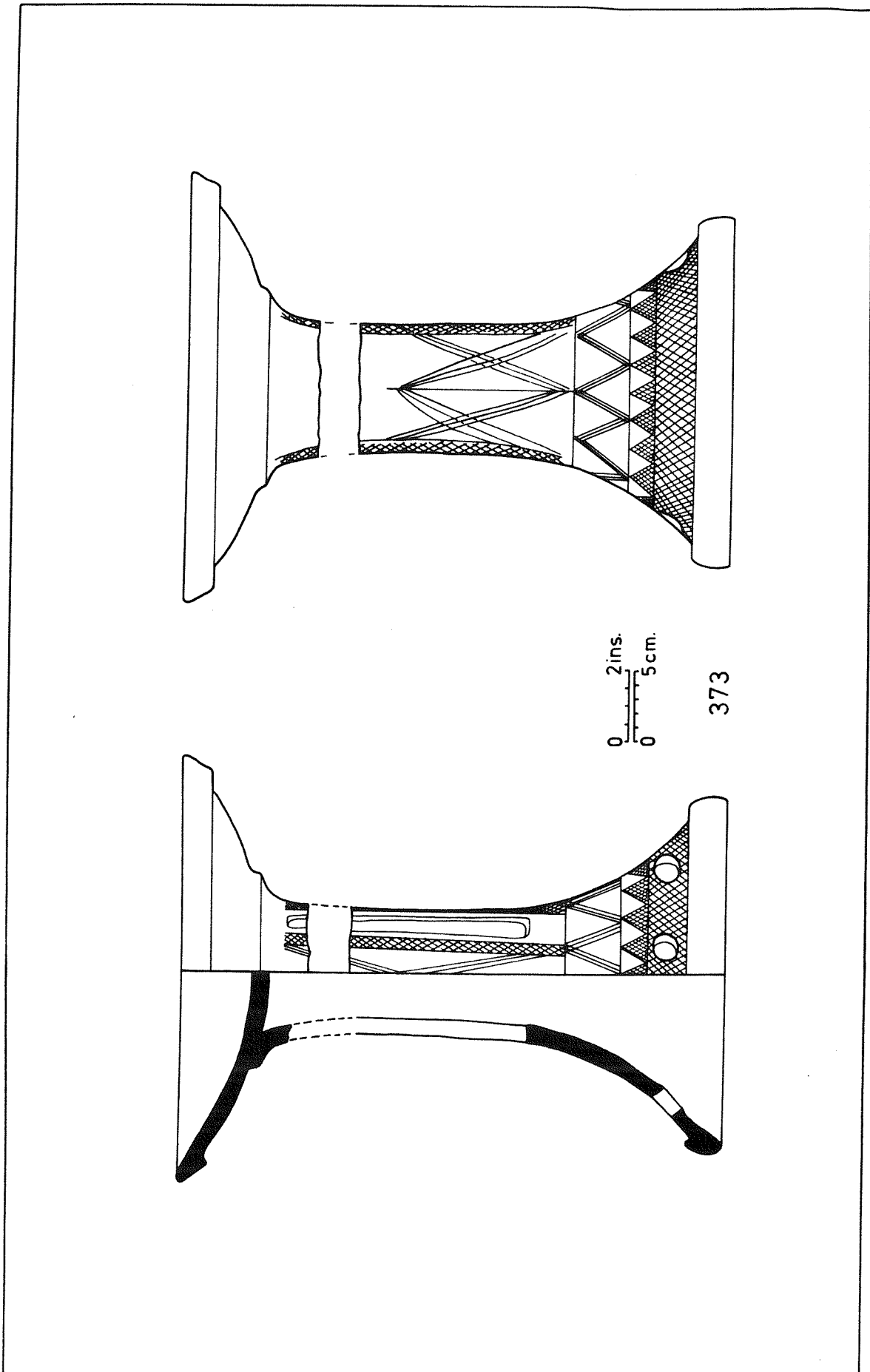

Fig. 8.33 Ur: Pottery sample 0373. Type 10; Stemmed dish ($\frac{1}{4}$)

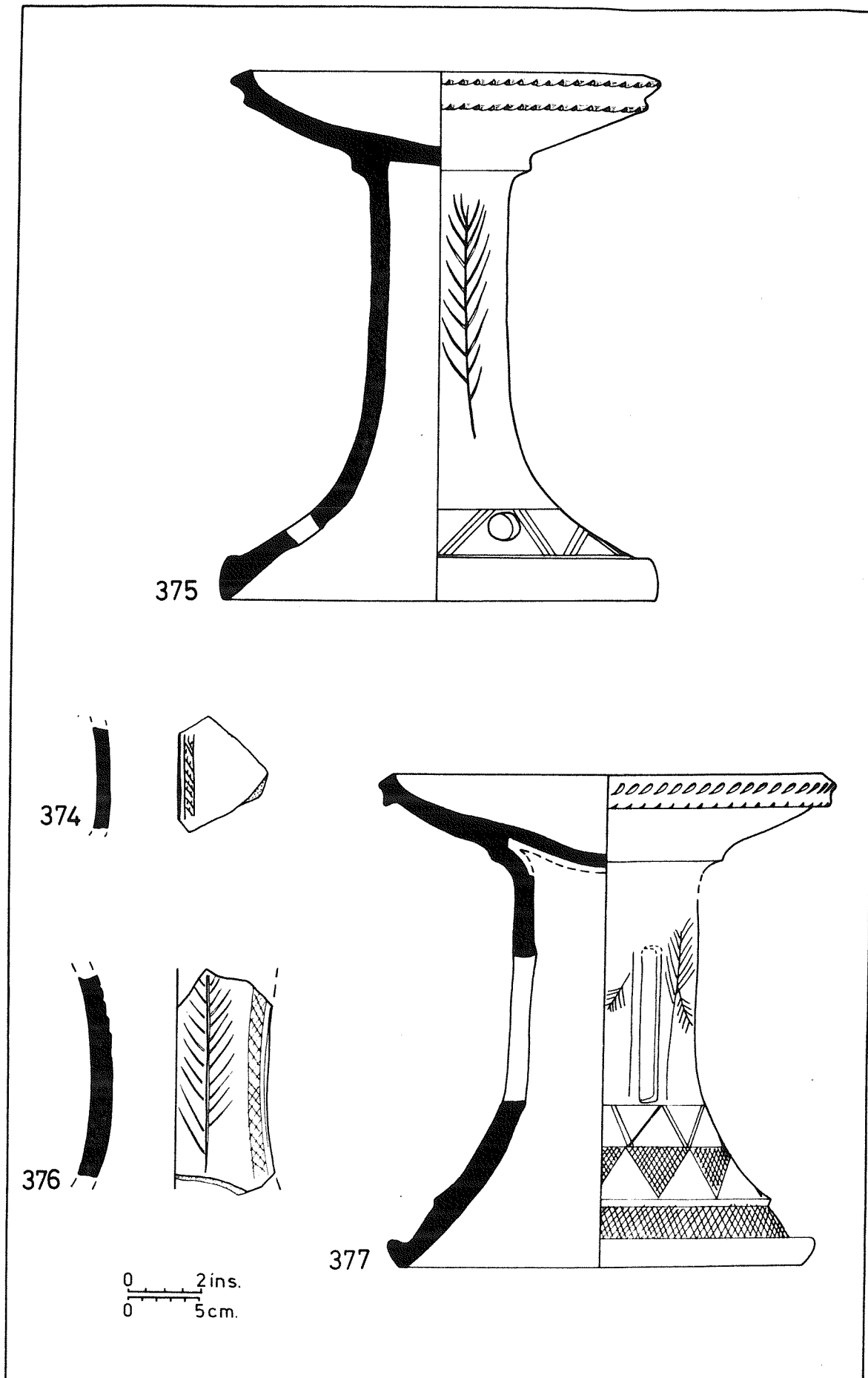

Fig. 8.34 Ur: Pottery samples 0374-0377. Type 10; Stemmed dishes ($\frac{1}{4}$)

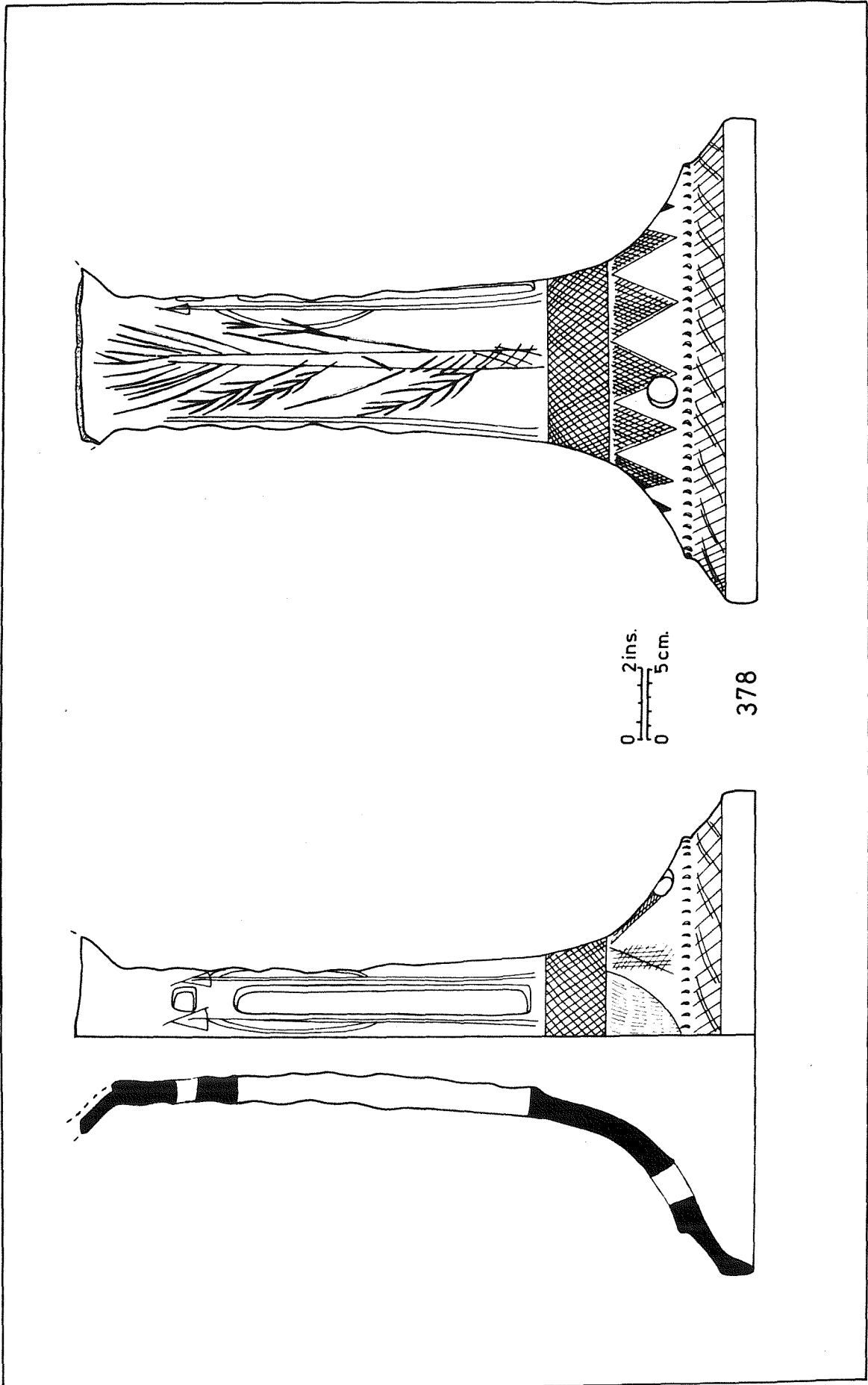

Fig. 8.35 Ur: Pottery sample 0378. Type 10; Stemmed dish (1/2)

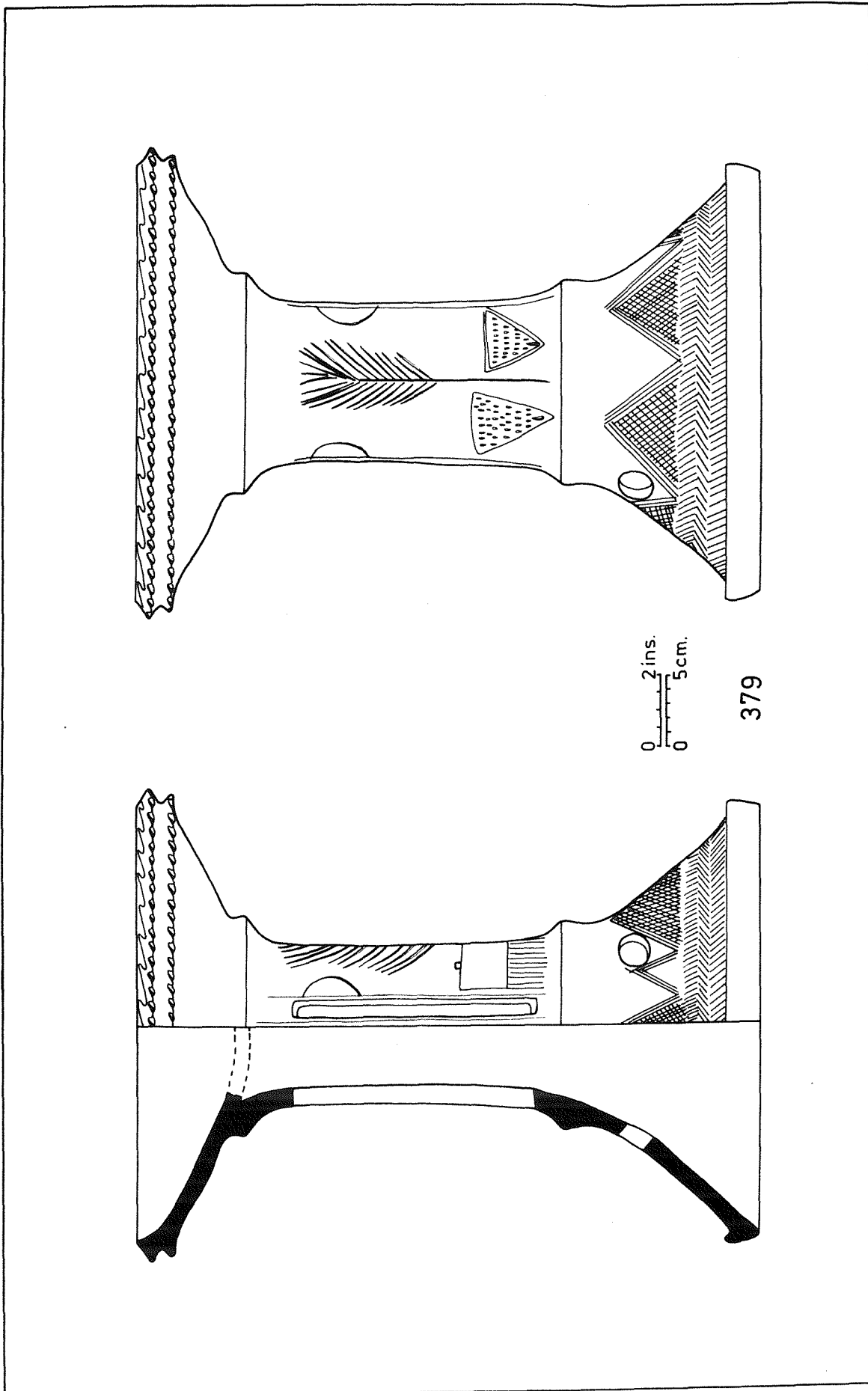

Fig. 8.36 Ur: Pottery sample 0379. Type 10; Stemmed dish ($\frac{1}{2}$)

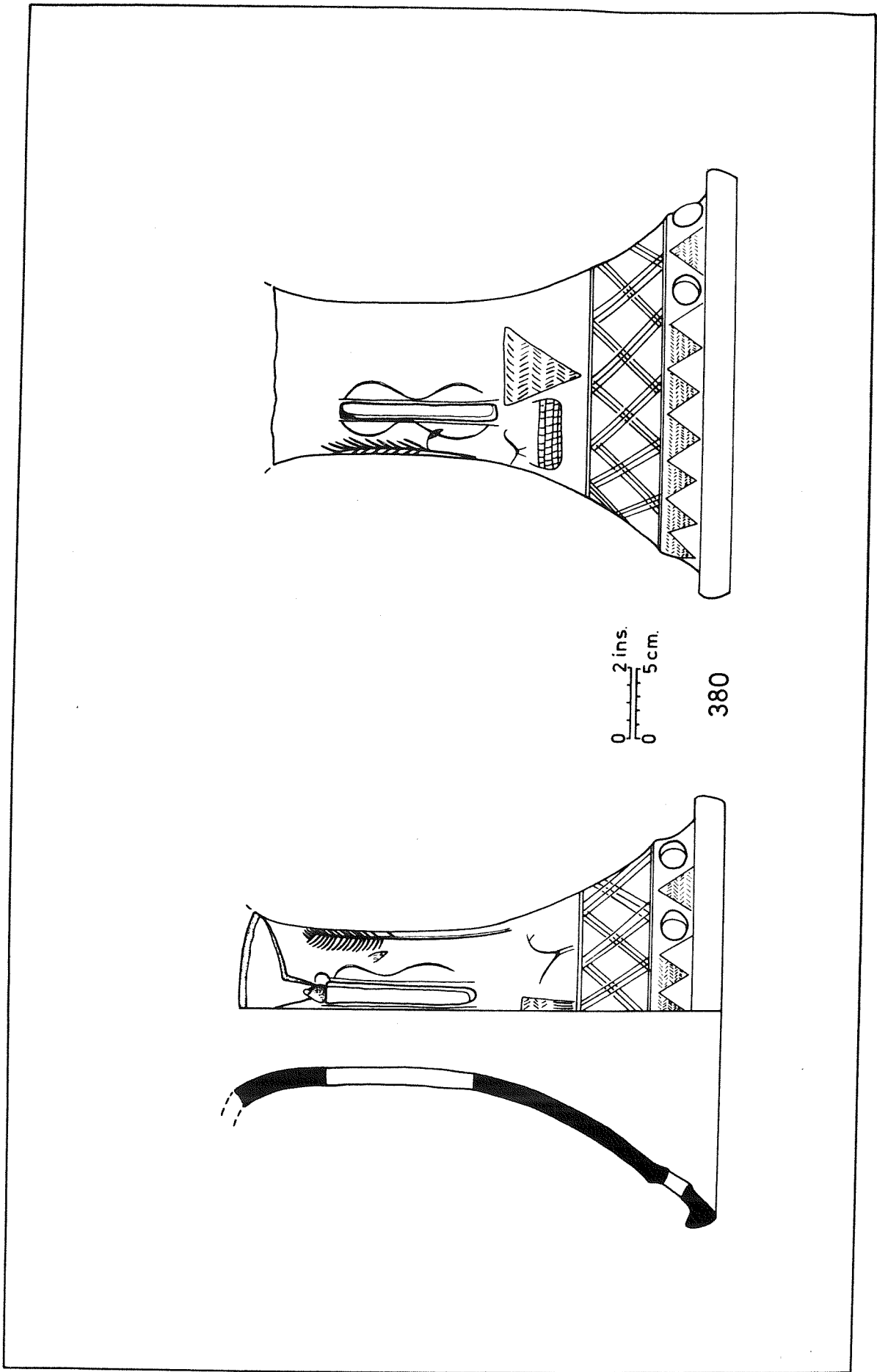

Fig. 8.37 Ur: Pottery sample 0380. Type 10; Stemmed dish ($\frac{1}{4}$)

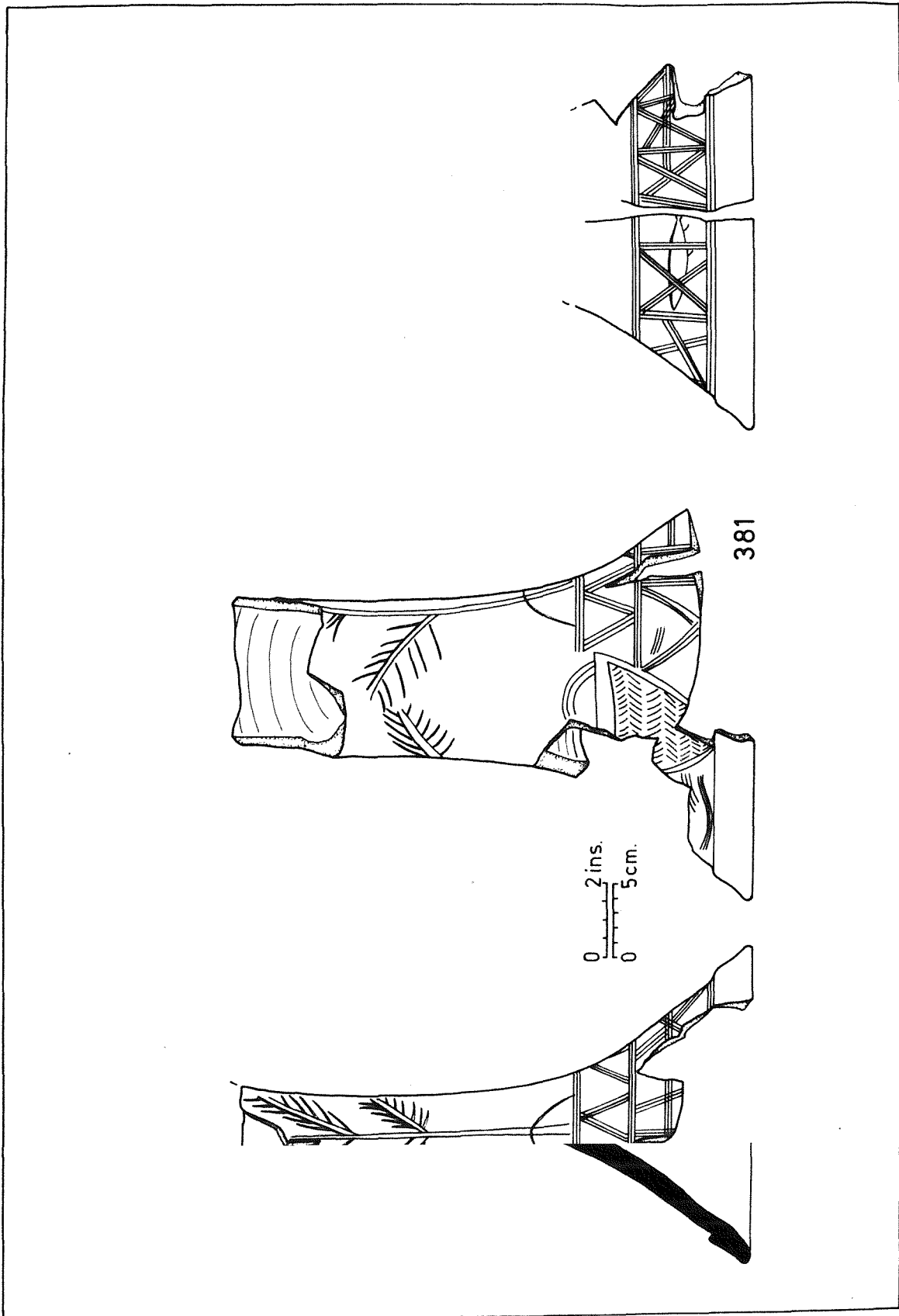

Fig. 8.38 Ur: Pottery sample 0381. Type 10; Stemmed dish ($\frac{1}{4}$)

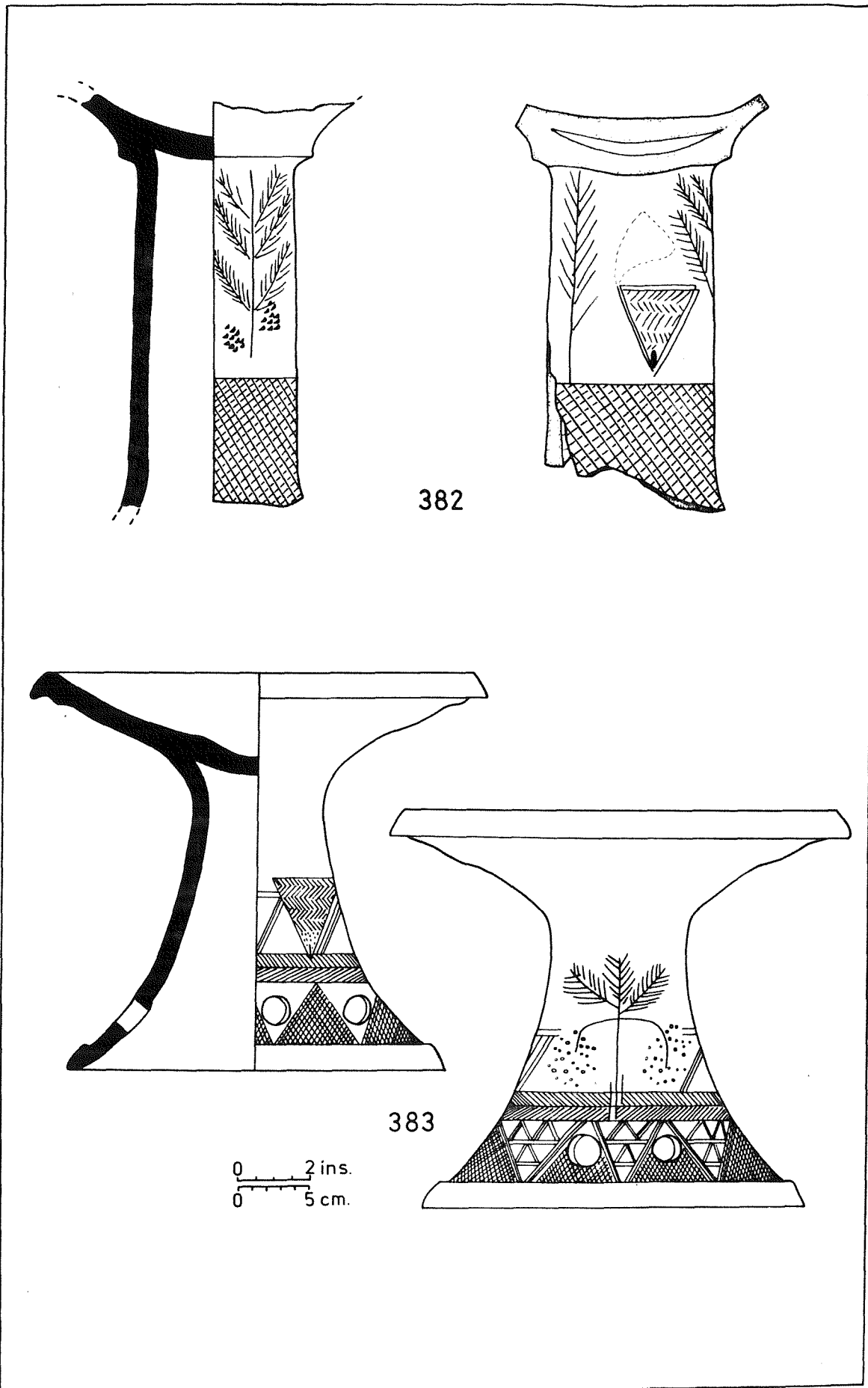

Fig. 8.39 Ur: Pottery samples 0382-0383. Type 10; Stemmed dishes (4)

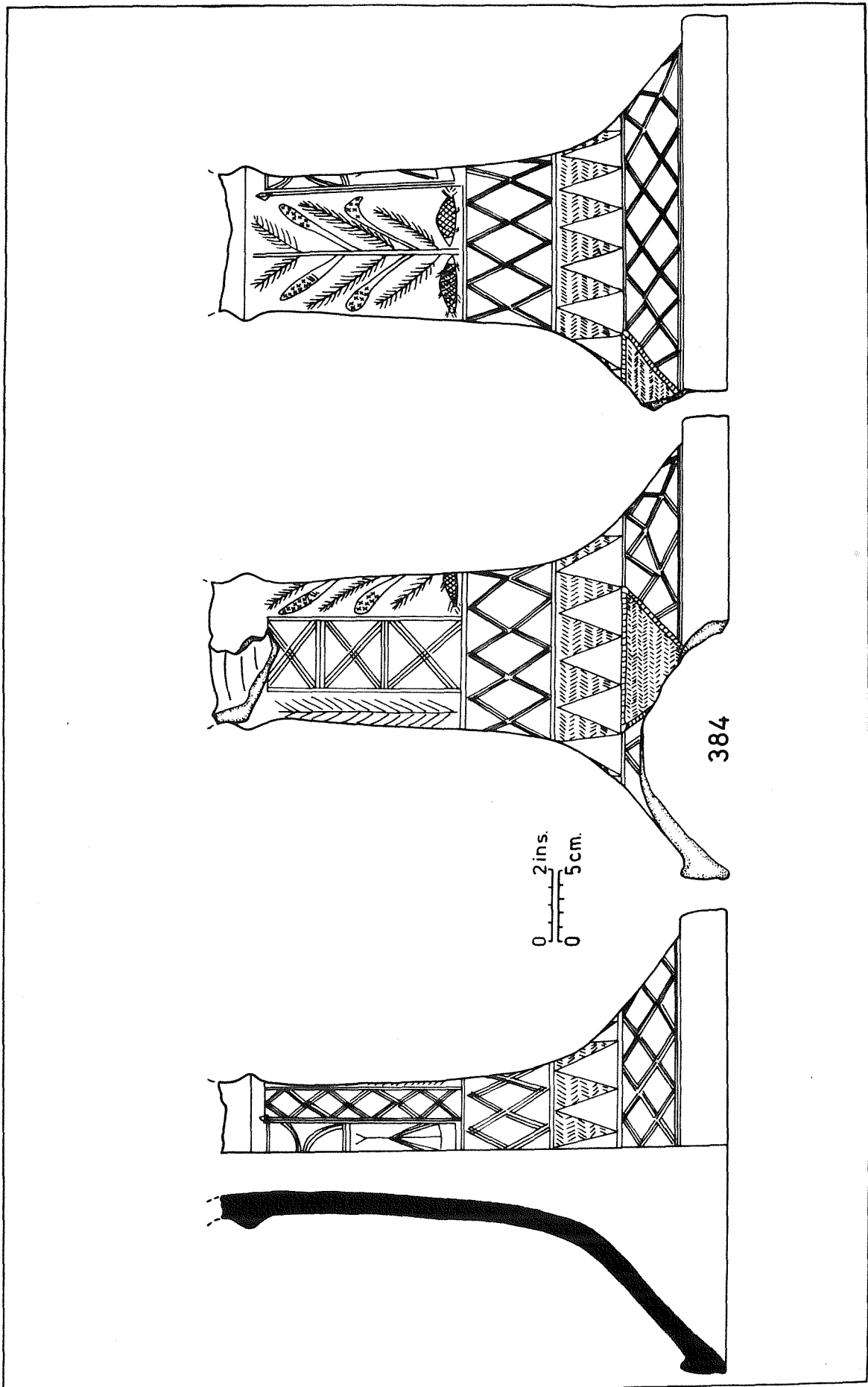

Fig. 8.40 Ur: Pottery sample 0384. Type 10; Stemmed dish ($\frac{1}{4}$)

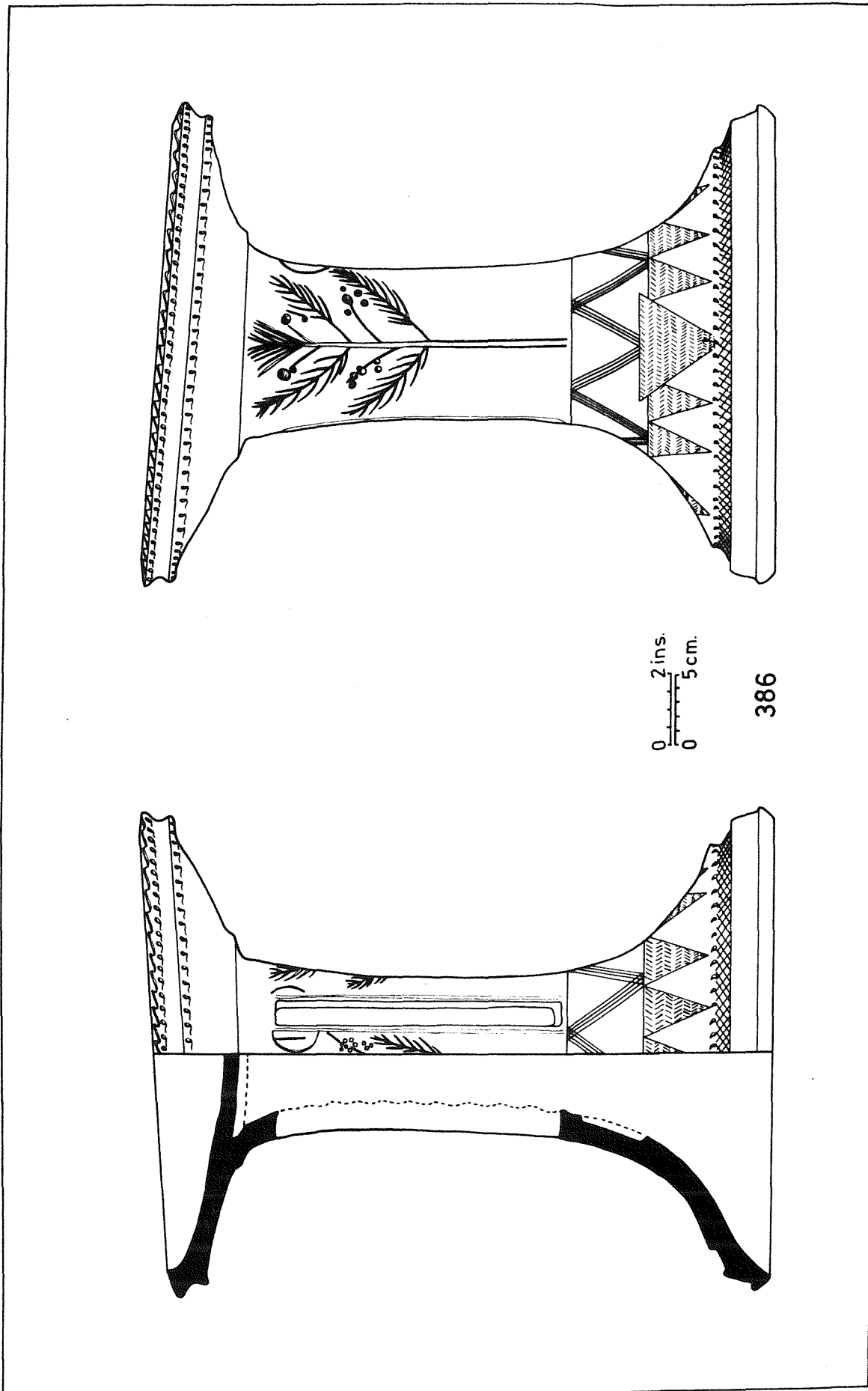

Fig. 8.41 Ur: Pottery sample 0386. Type 10; Stemmed dish ($\frac{1}{4}$)

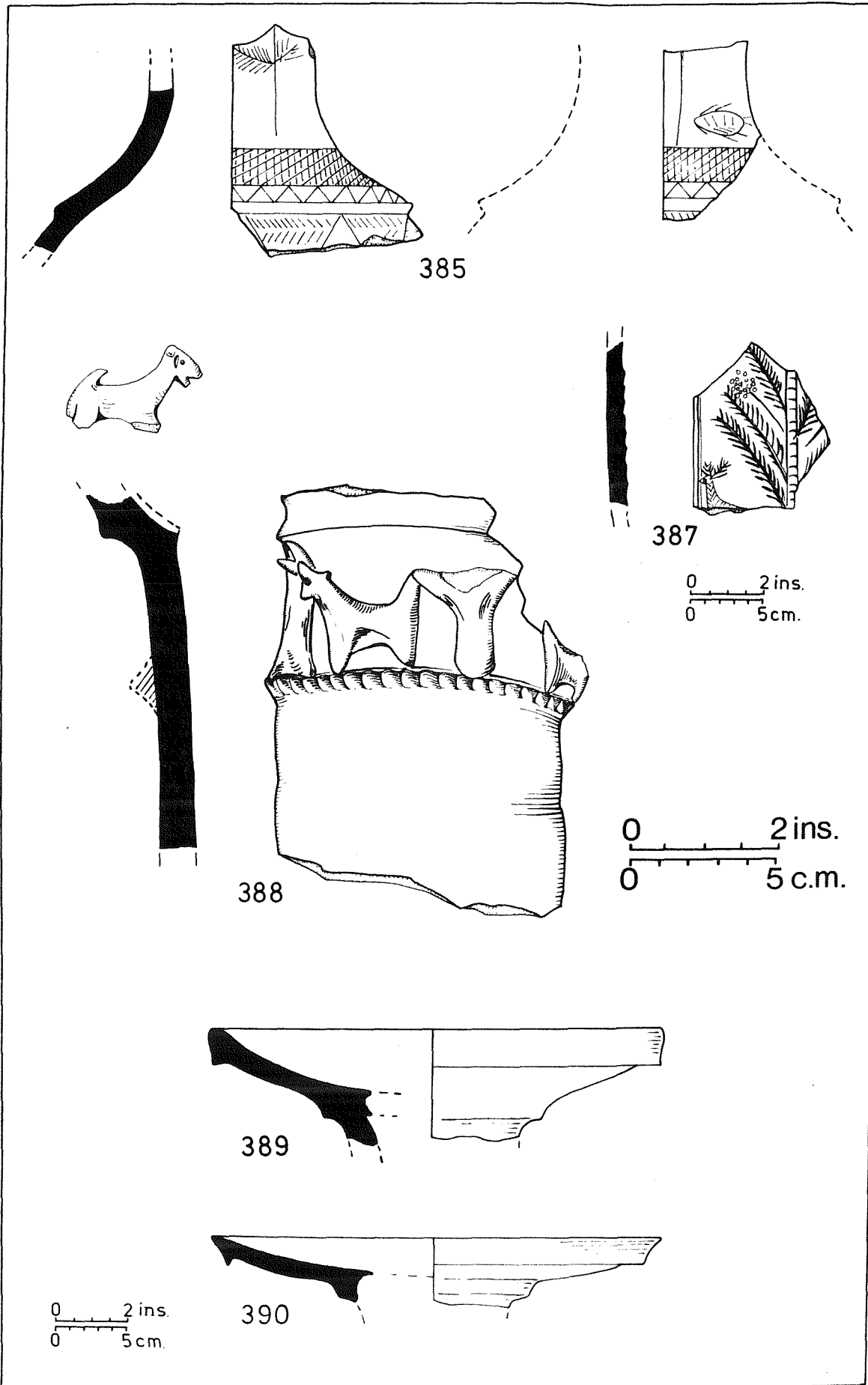

Fig. 8.42 Ur: Pottery samples 0385-0390. Type 10; Stemmed dishes ($\frac{1}{4}$) and ($\frac{1}{2}$)

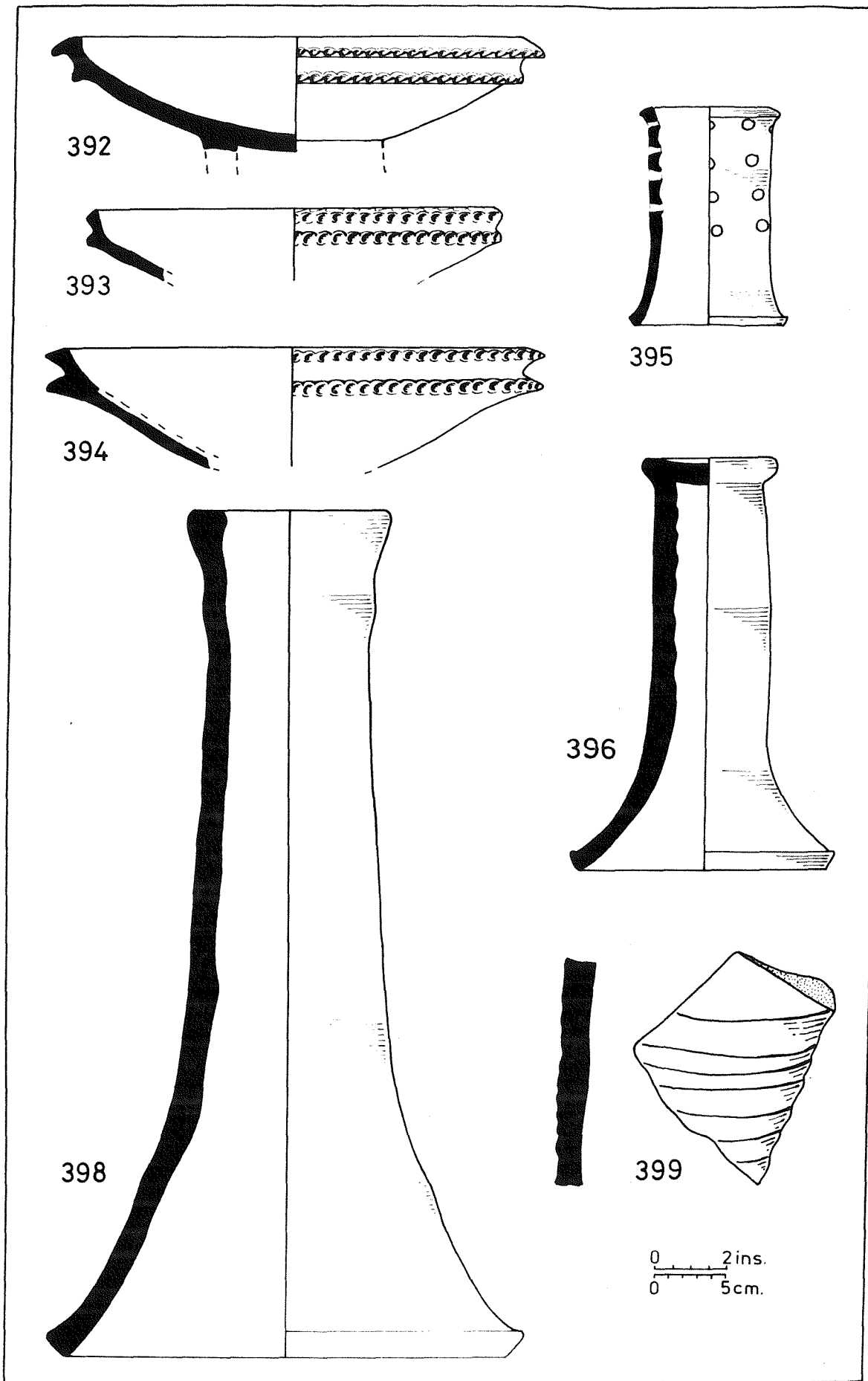

Fig. 8.43 Ur: Pottery samples 0392-0399. Types 10 and 11; Stemmed dishes and Hollow stands ($\frac{1}{4}$)

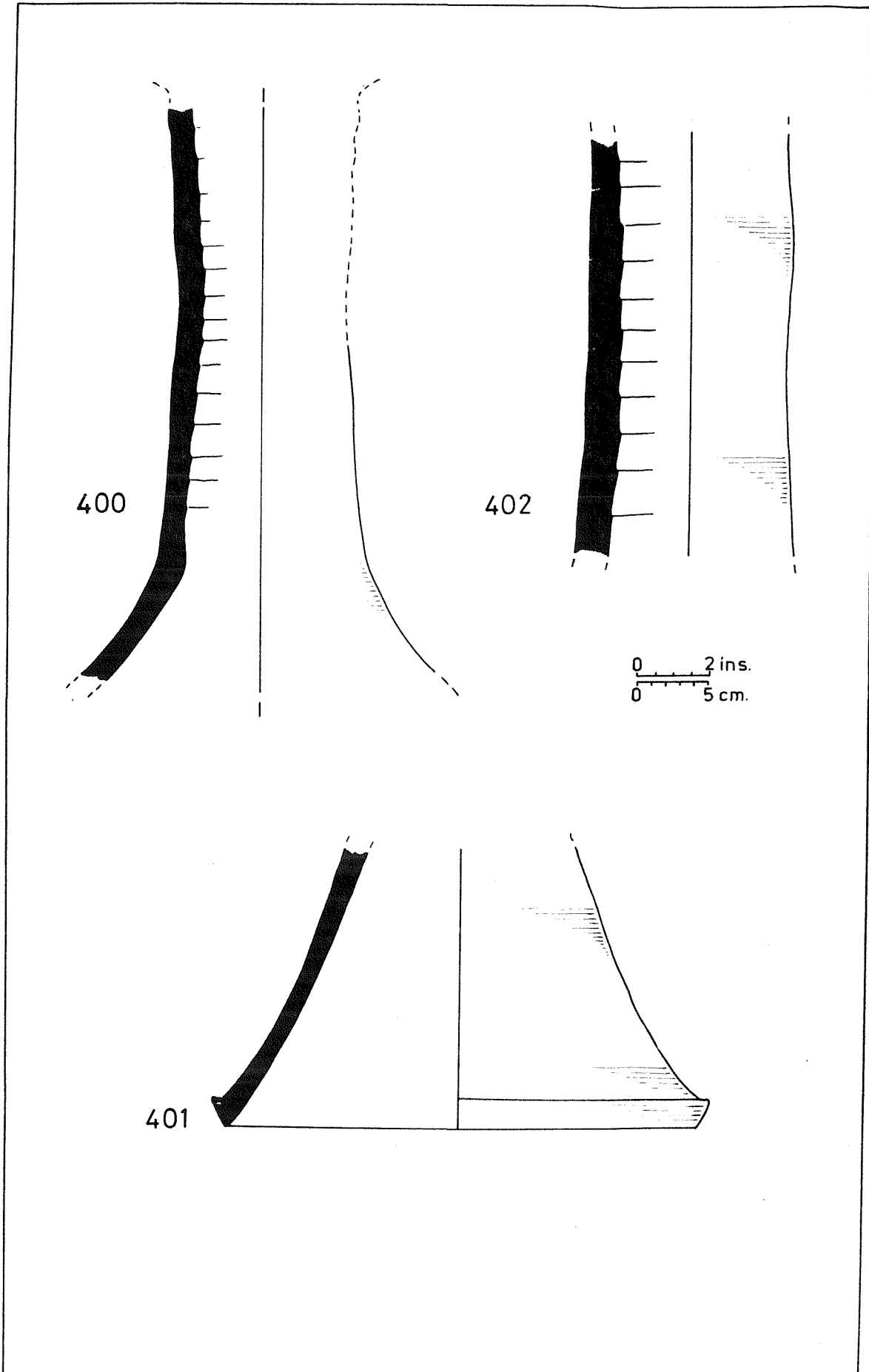

Fig. 8.44 Ur: Pottery samples 0400-0402. Type 11; Hollow stands ($\frac{1}{2}$)

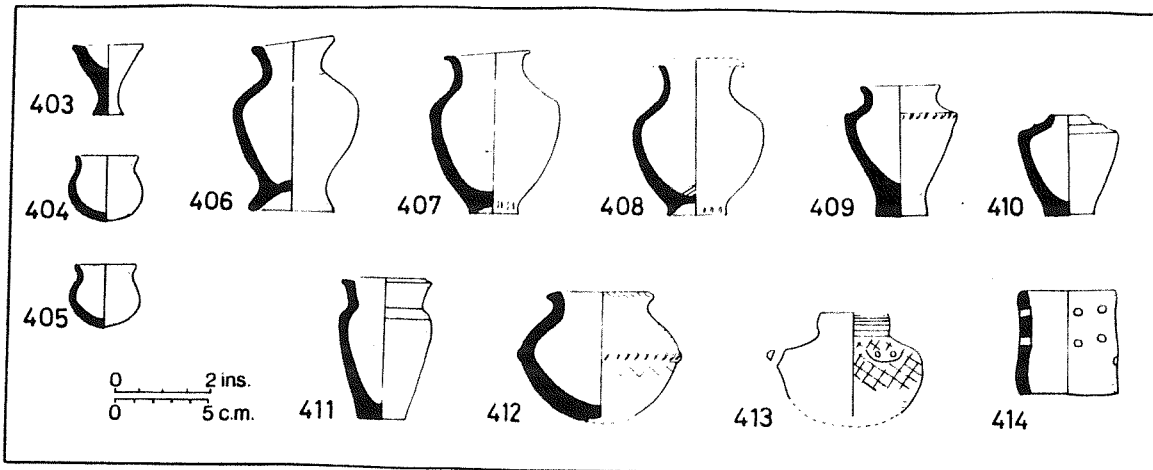

Fig. 8.45 Ur: Pottery samples 0403-0414. Type 12; Miniatures ($\frac{1}{4}$)

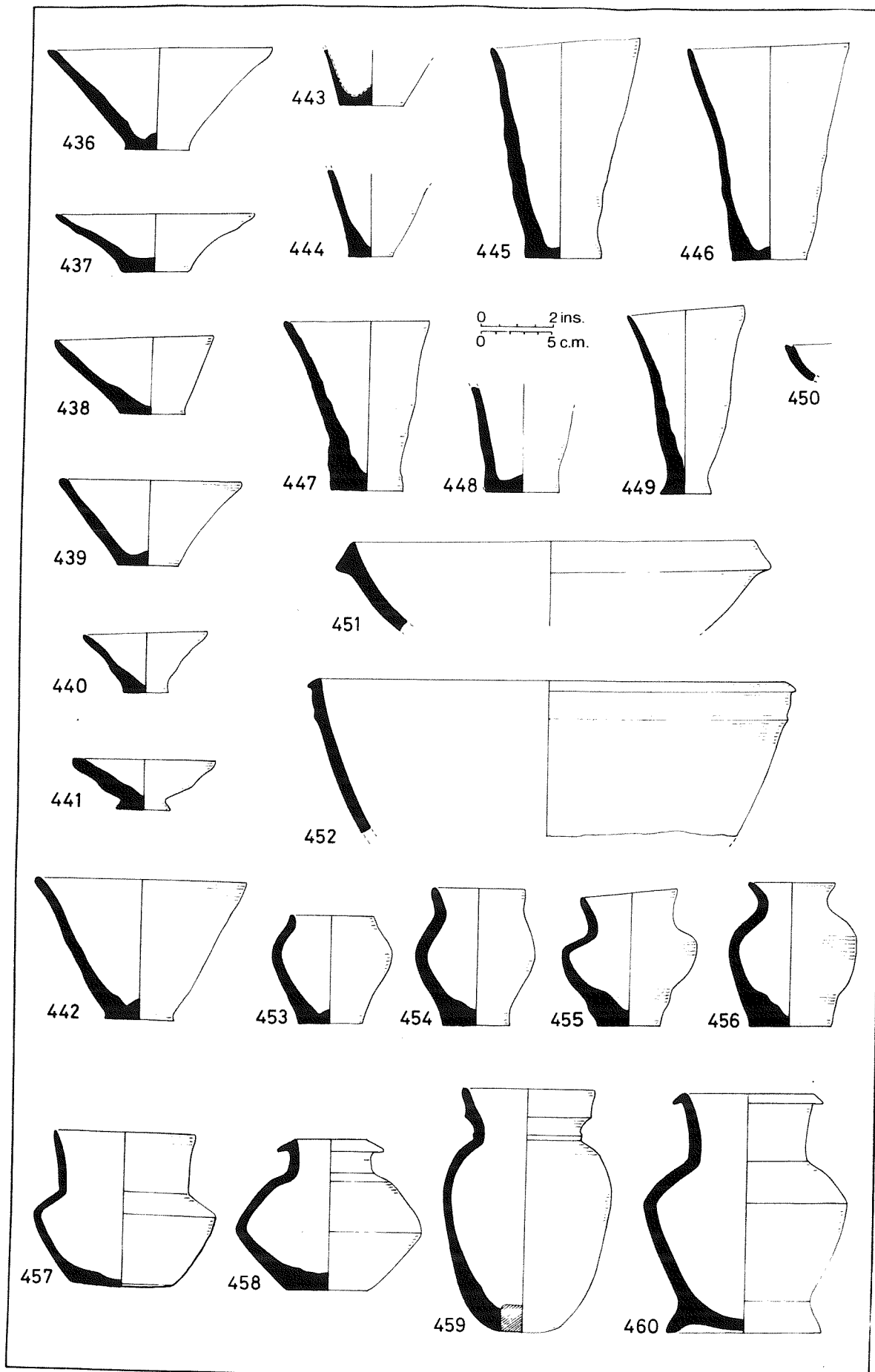

Fig. 8.46 Tell al 'Ubaid: Pottery samples 0436-0460. Types 1.1; 1.3; 1.14; 2.1; 2.2 and 2.3 ($\frac{1}{4}$)

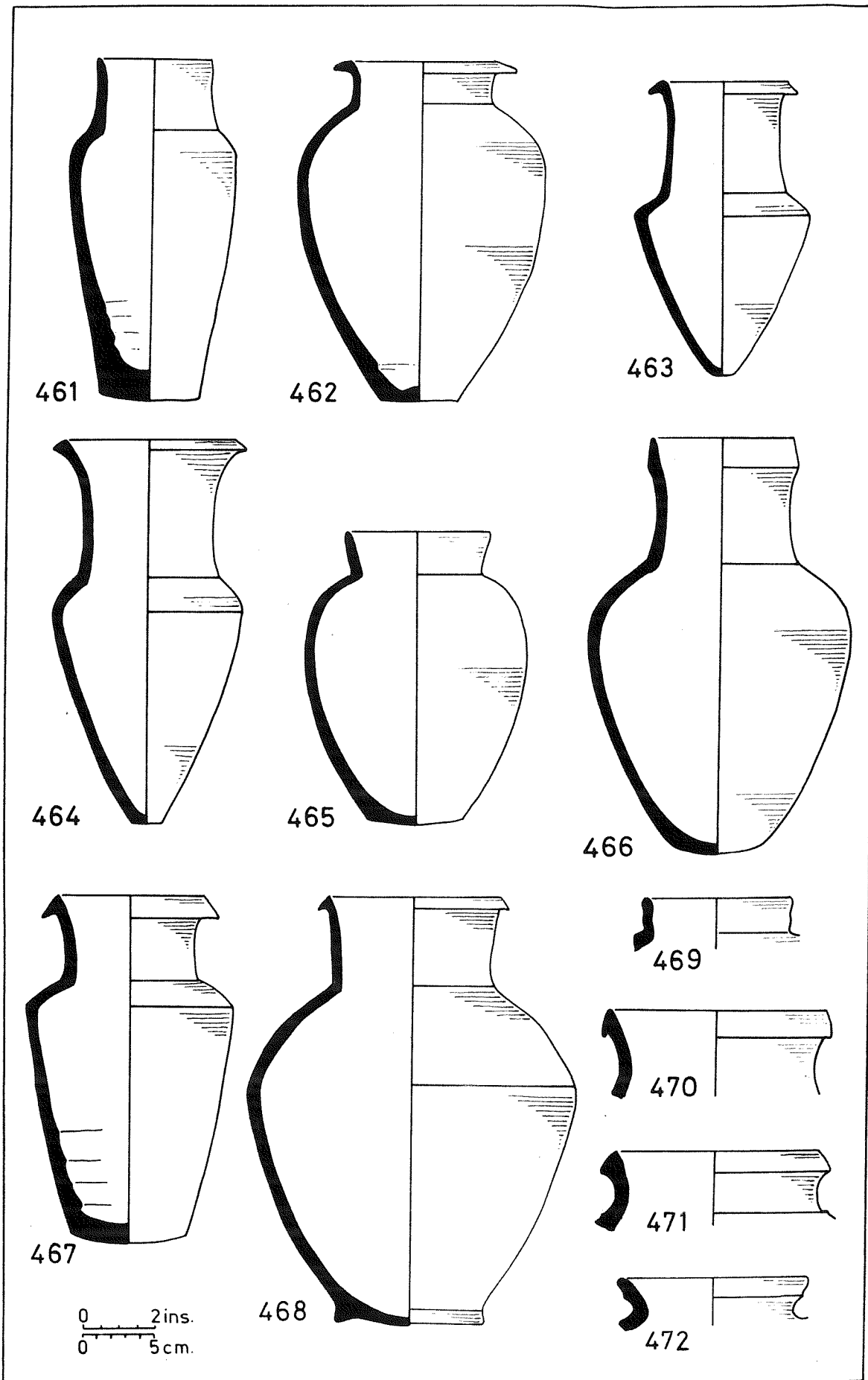

Fig. 8.47 Tell al 'Ubaid: Pottery samples 0461-0472. Types 2.3.1; 2.3.2; 2.3.4; 2.4.3; 2.4.5 and 2.4.6; Large jars and jar rim sherds ($\frac{1}{4}$)

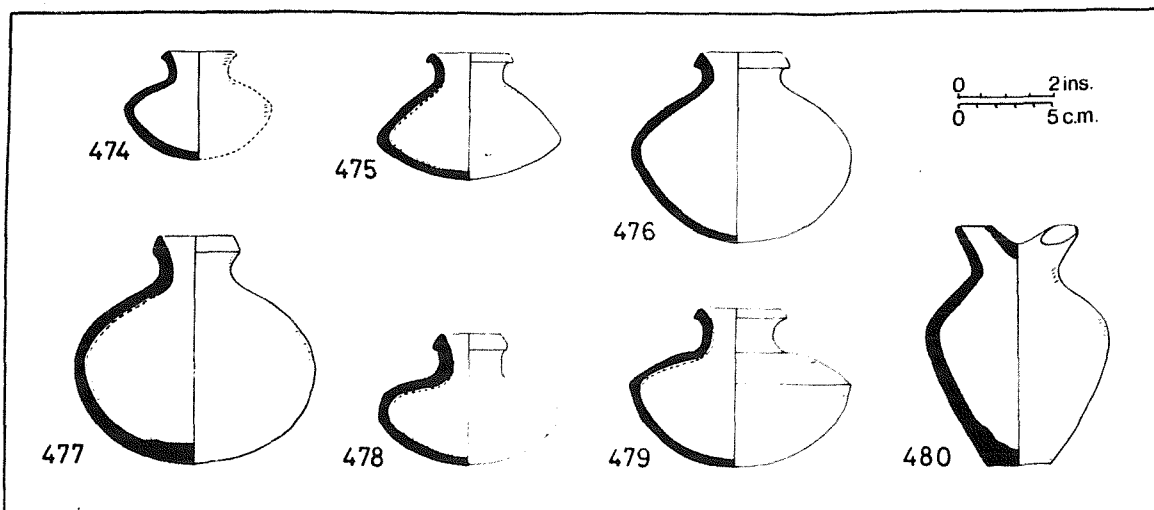

Fig. 8.48 Tell al 'Ubaid: Pottery samples 0474-0480. Type 3; Bottles
($\frac{1}{2}$)

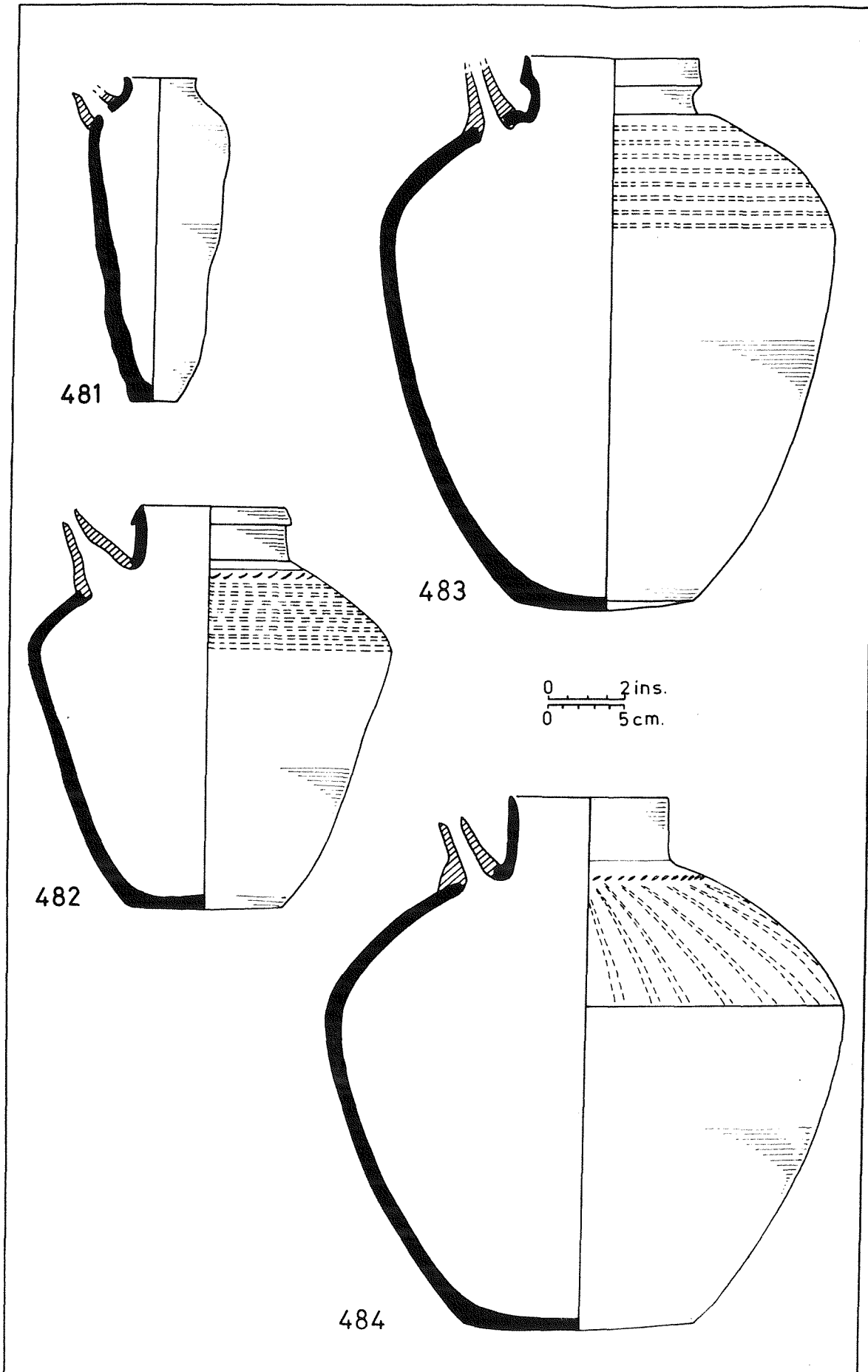

Fig. 8.49 Tell al 'Ubaid: Pottery samples 0481-0484. Type 5.1; Spouted jars ($\frac{1}{4}$)

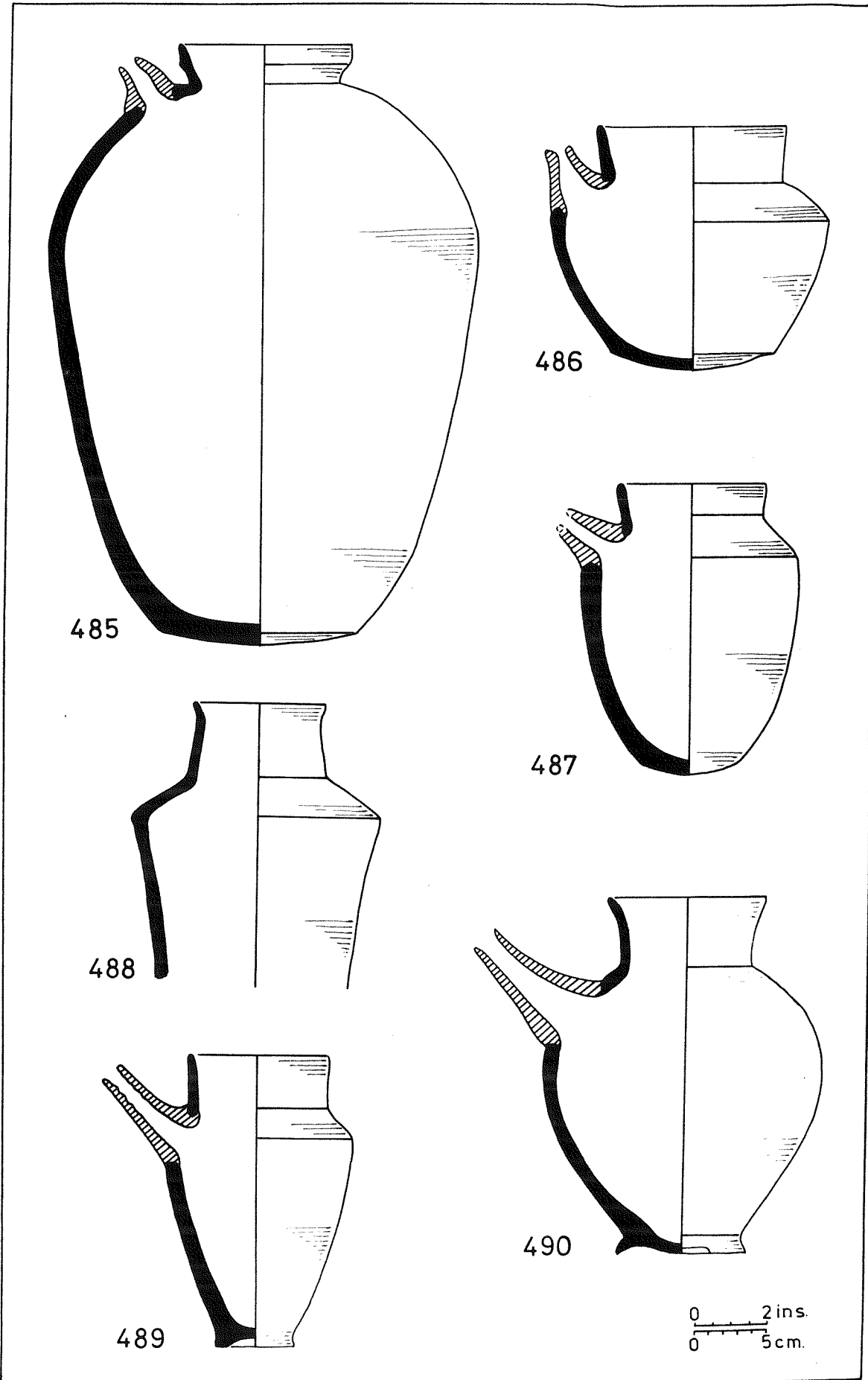

Fig. 8.50 Tell al 'Ubaid: Pottery samples 0485-0490. Types 5.2; 5.3 and 5.4; Spouted jars ($\frac{1}{4}$)

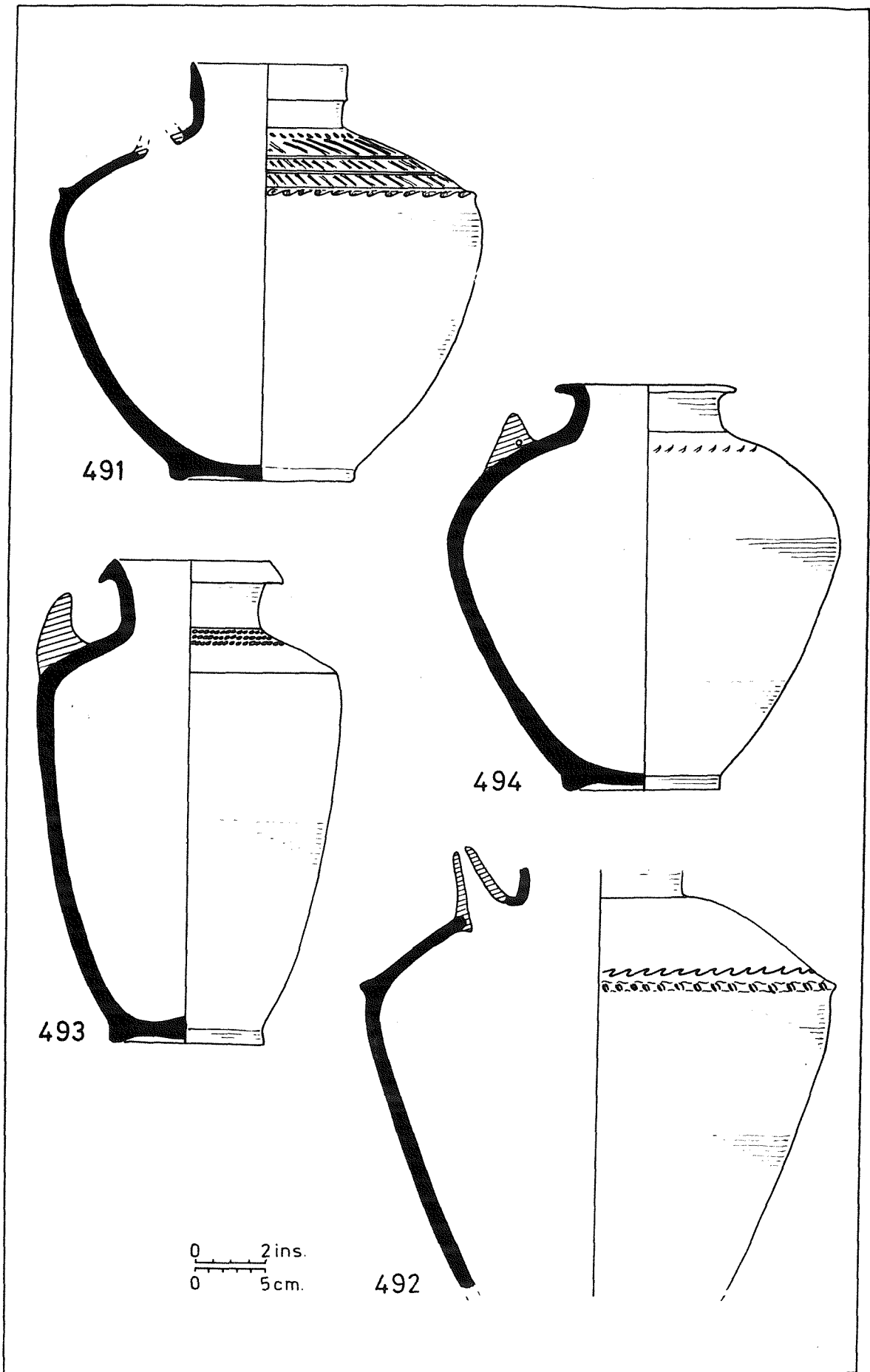

Fig. 8.51 Tell al 'Ubaid: Pottery samples 0491-0494. Types 5.4 and 6; Spouted jars and wing-lugged jars ($\frac{1}{2}$)

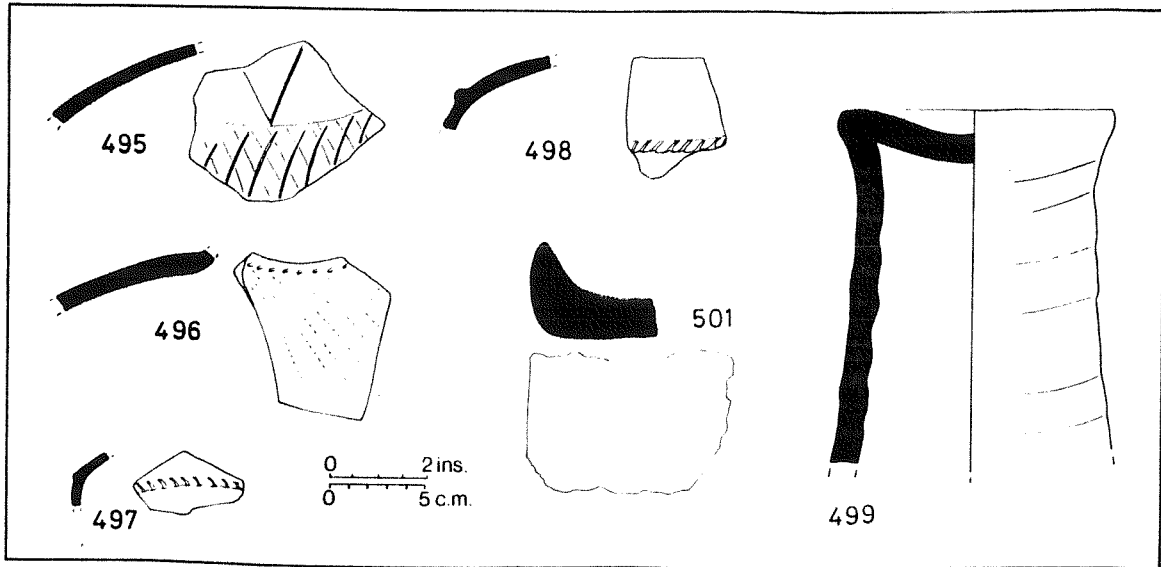

Fig. 8.52 Tell al 'Ubaid: Pottery samples 0495-0501. Types 8.5; 8.9; 8.12; and 11; Decorated jar sherds and Hollow stands (4)

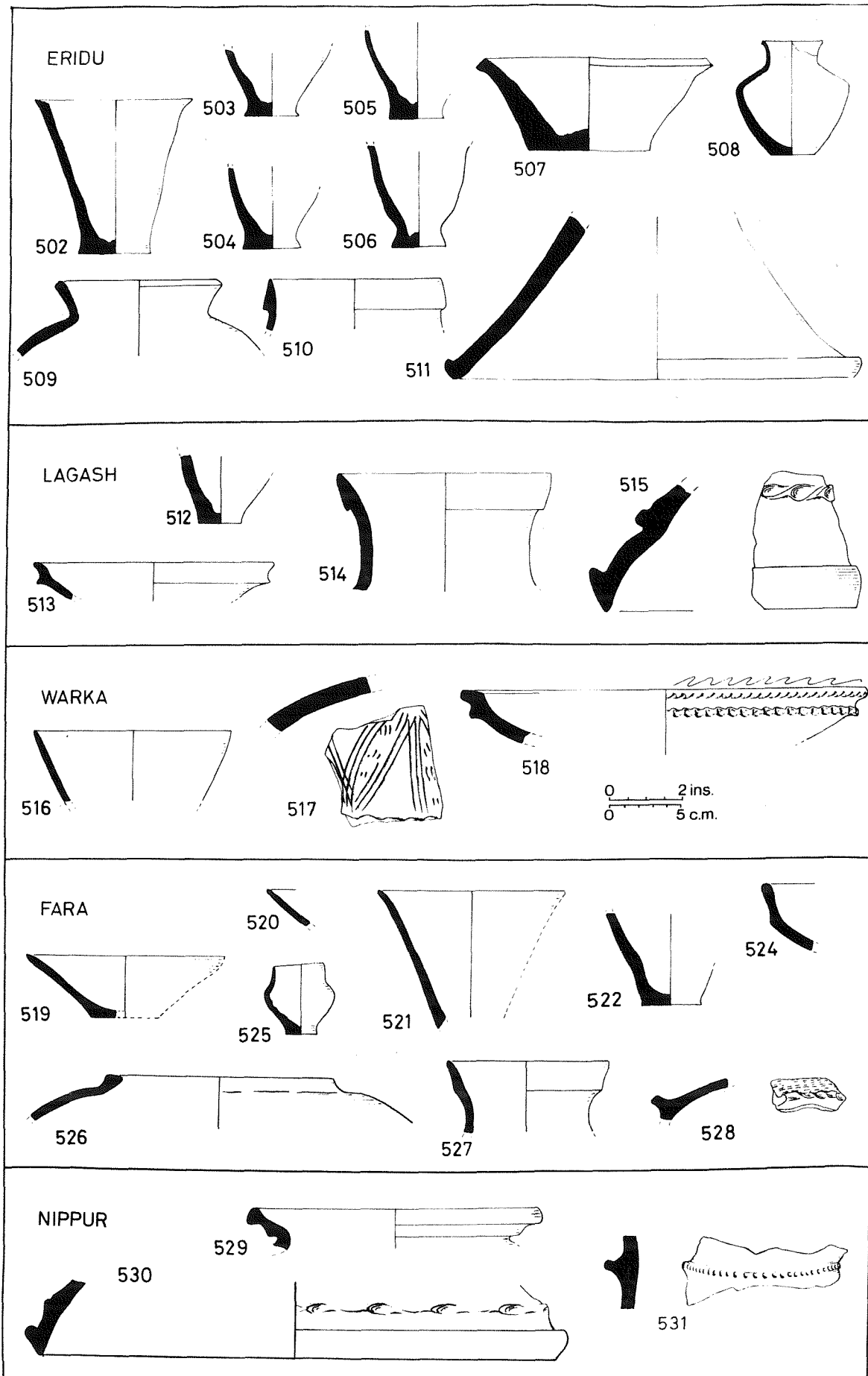

Fig. 8.53 Eridu: Pottery samples 0502-0511. Lagash: Pottery samples 0512-0515. Warka: Pottery samples 0516-0518. Fara: Pottery samples 0519-0528. Nippur: Pottery samples 0529-0531 ($\frac{1}{4}$)

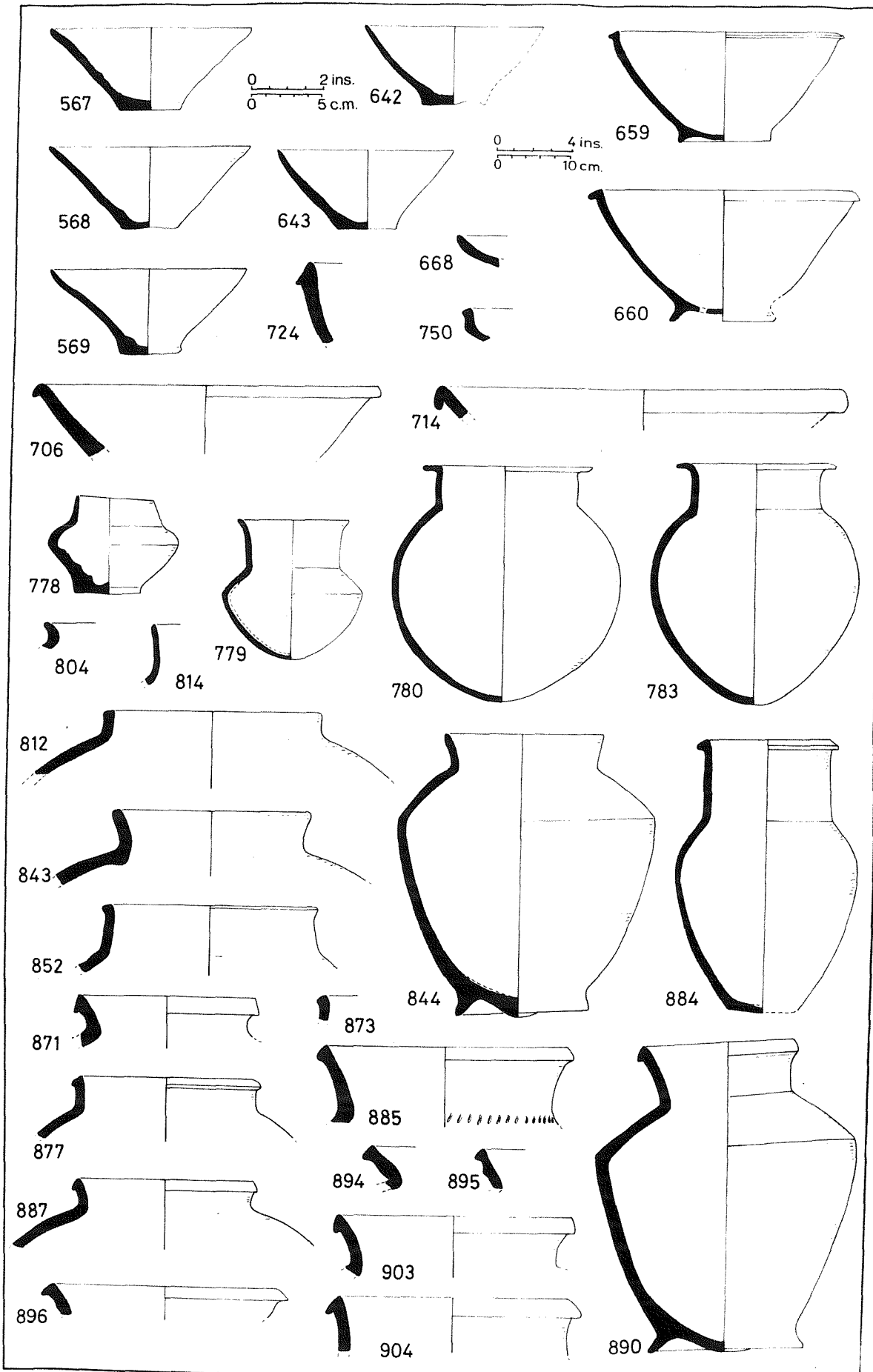

Fig. 8.54 Abu Salabikh: Main Mound, Area E: Pottery samples 0567-0904. Types 1.1; 1.7; 1.14; 2.1; 2.2; 2.3 and 2.4 (¼)

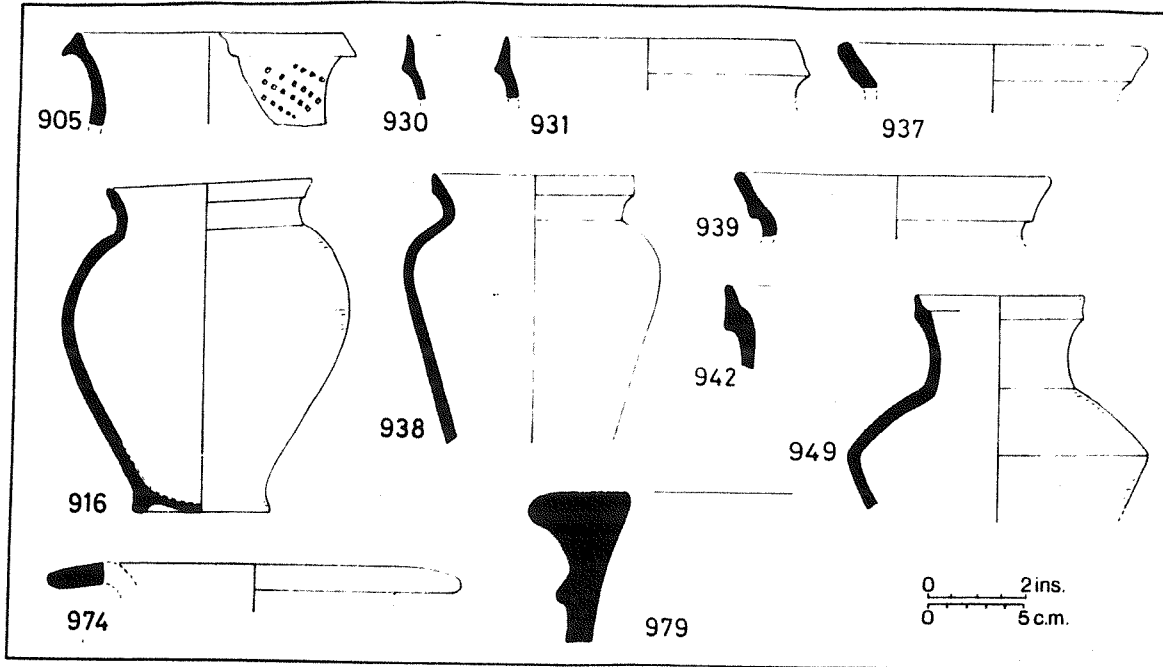

Fig. 8.55 Abu Salabikh: Main Mound, Area E: Pottery samples 0905-0979. Types 2.3.4 and 2.4 ($\frac{1}{4}$)

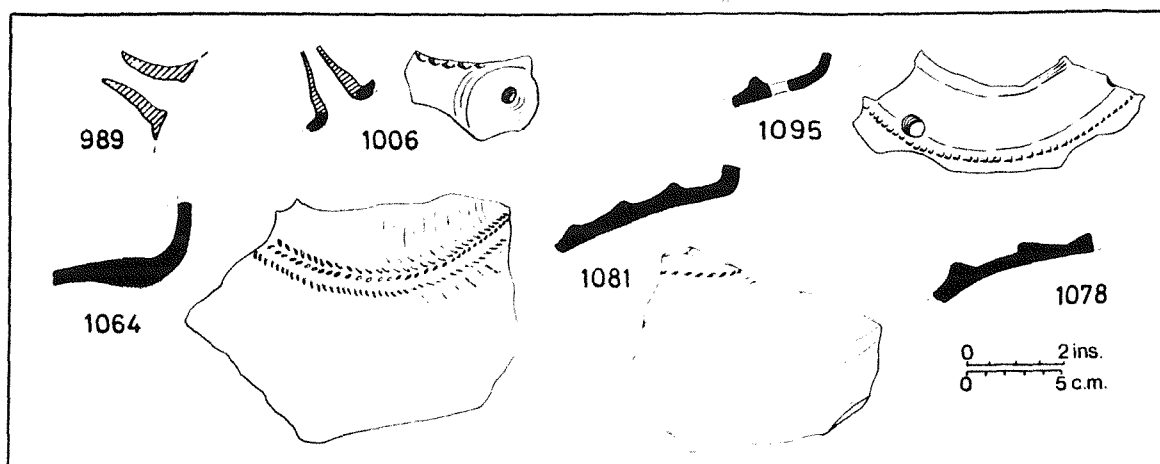

Fig. 8.56 Abu Salabikh: Main Mound, Area E: Pottery samples 0989-1095. Types 5.9; 8.10; 8.11 and 8.12 ($\frac{1}{4}$)

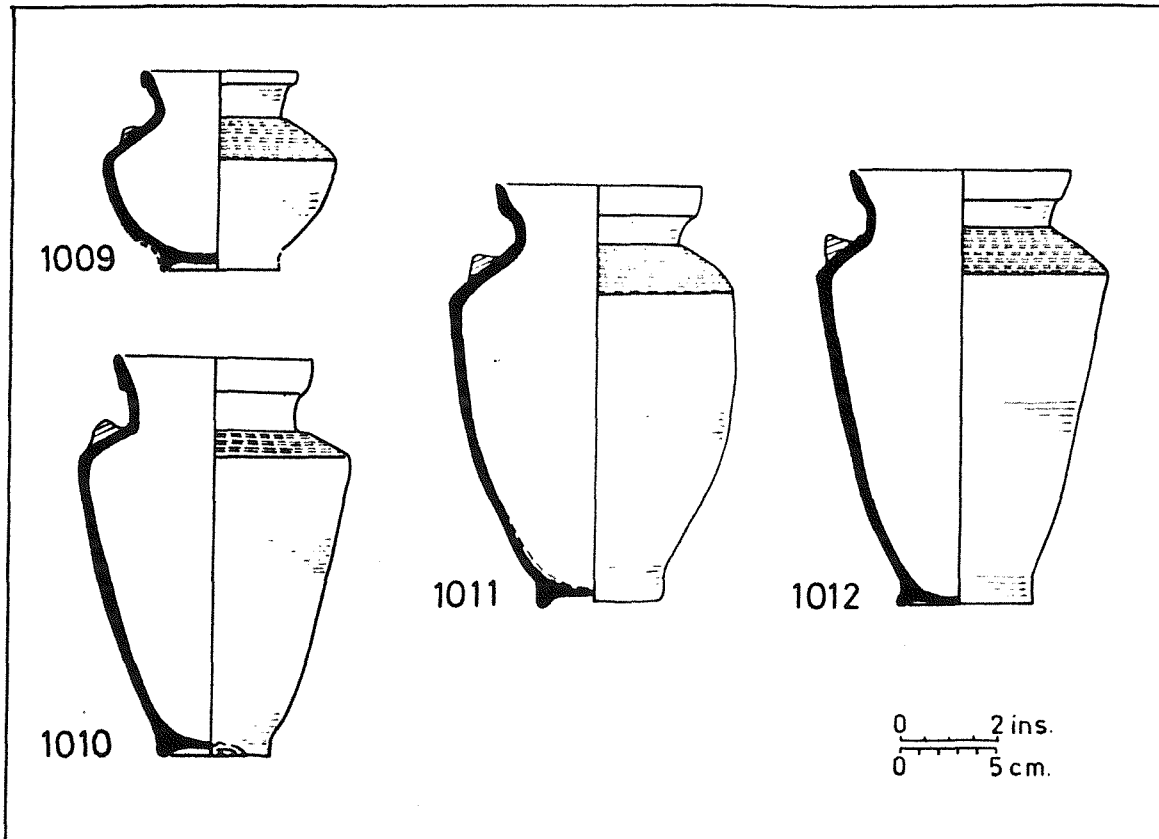

Fig. 8.57 Abu Salabikh: Main Mound, Area E: Pottery samples 1009-1012. Type 6; Wing-lugged jars ($\frac{1}{4}$)

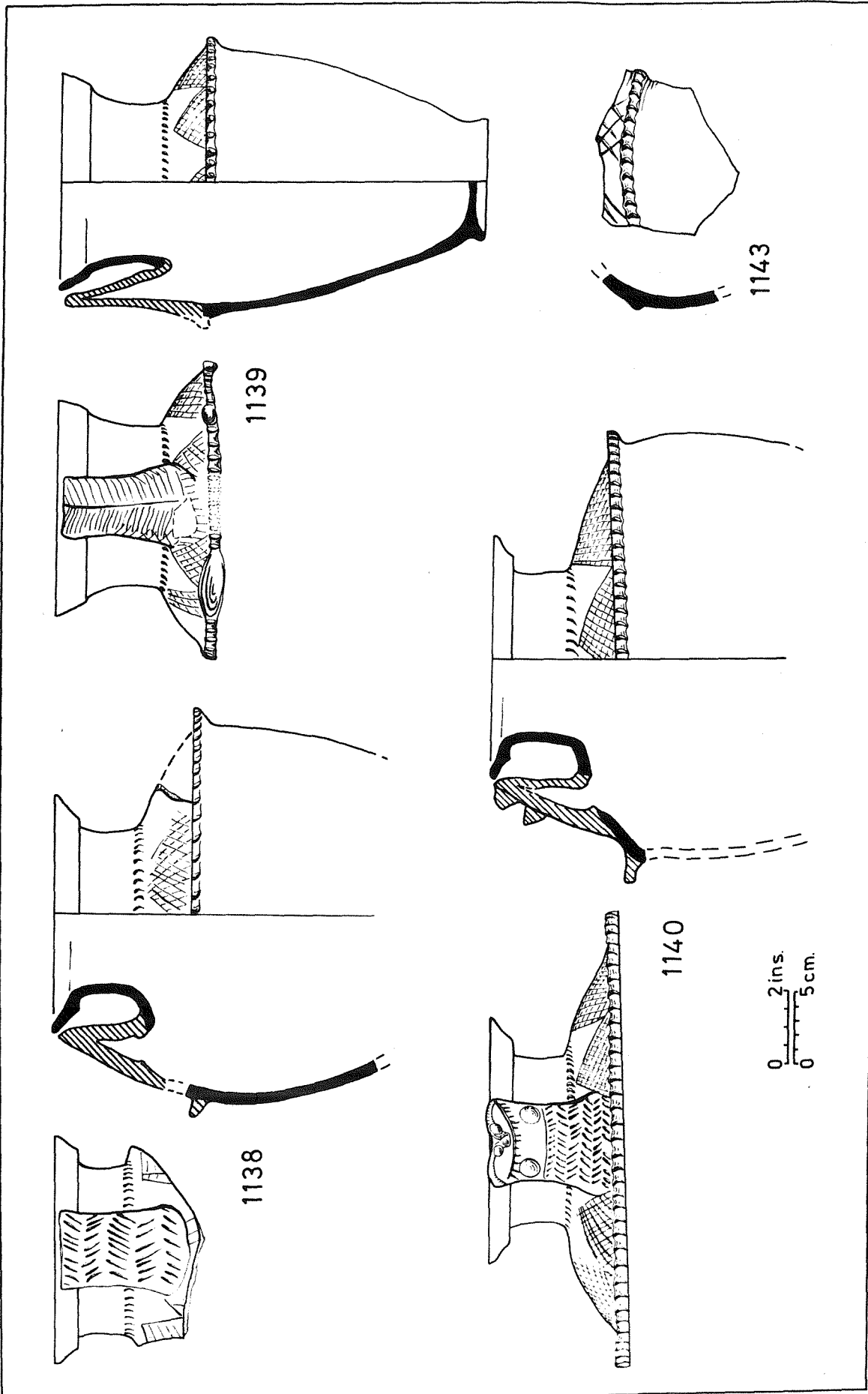

Fig. 8.58 Abu Salabikh: Main Mound, Area E: Pottery samples 1138-1143. Type 6; Upright-handled jars ($\frac{1}{4}$)

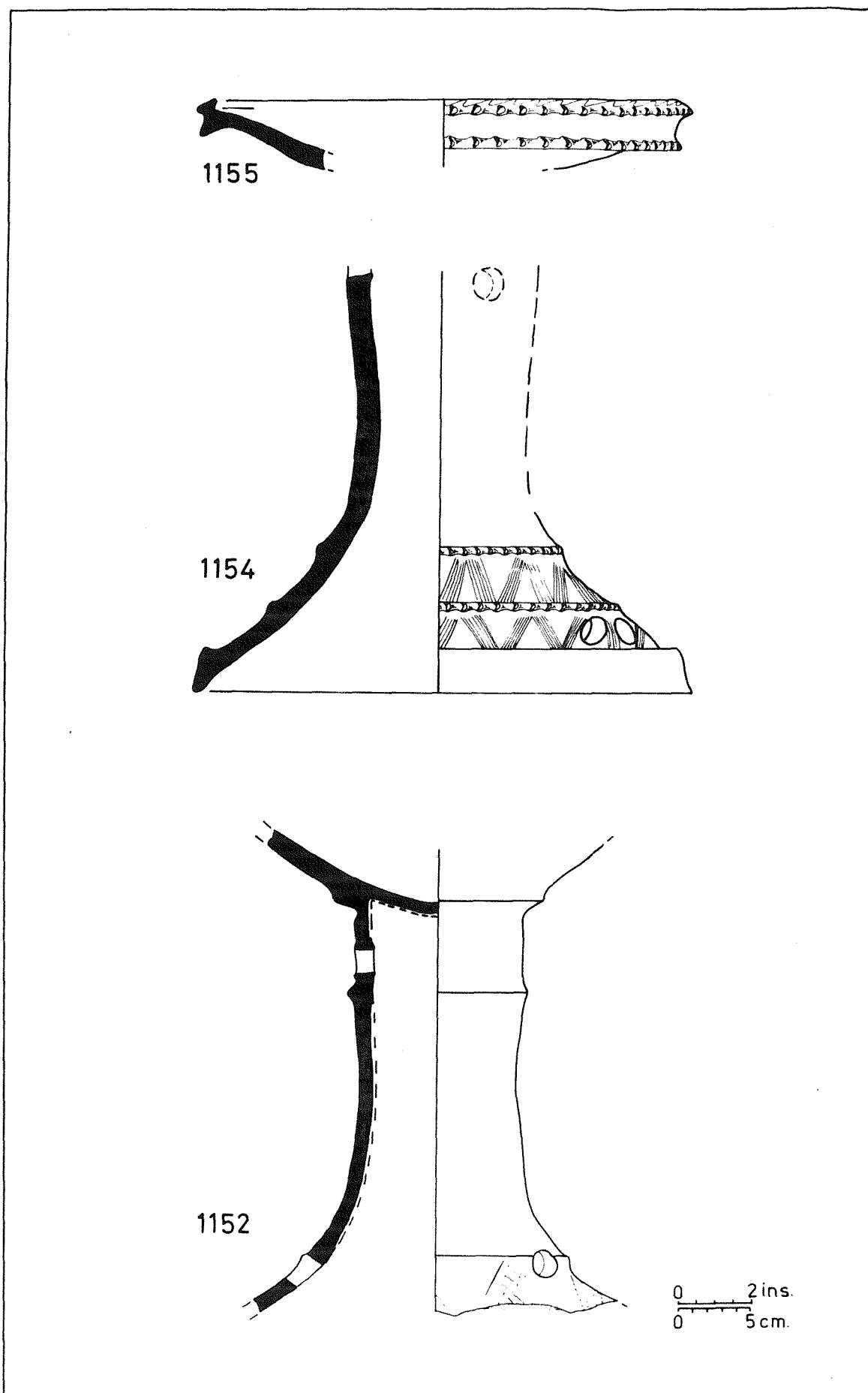

Fig. 8.59 Abu Salabikh: Main Mound, Area E: Pottery samples 1152-1155. Type 10; Stemmed dishes ($\frac{1}{4}$)

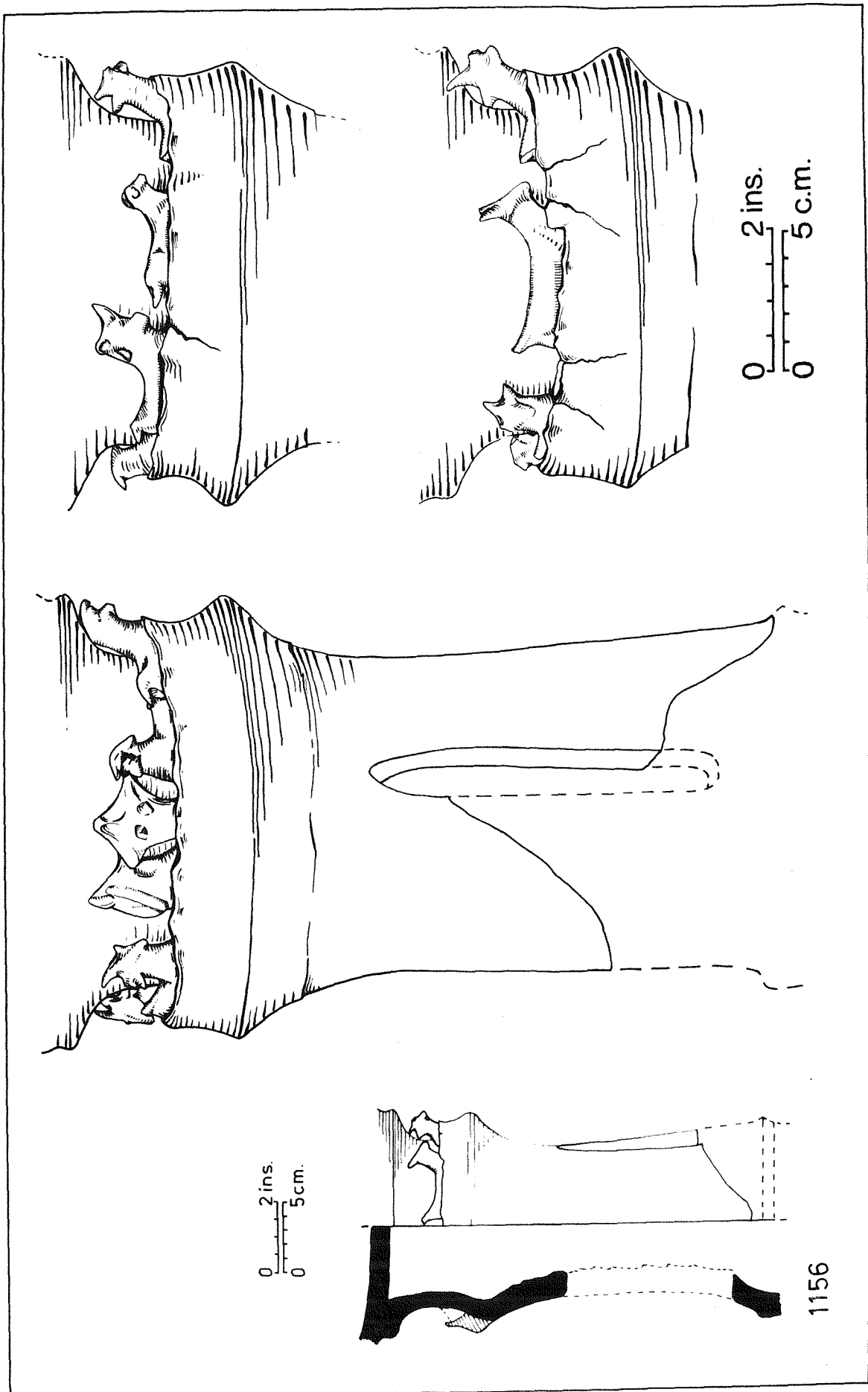

Fig. 8.60 Abu Salabikh: Main Mound, Area E: Pottery sample 1156.
Type 10; Stemmed dish ($\frac{1}{4}$)

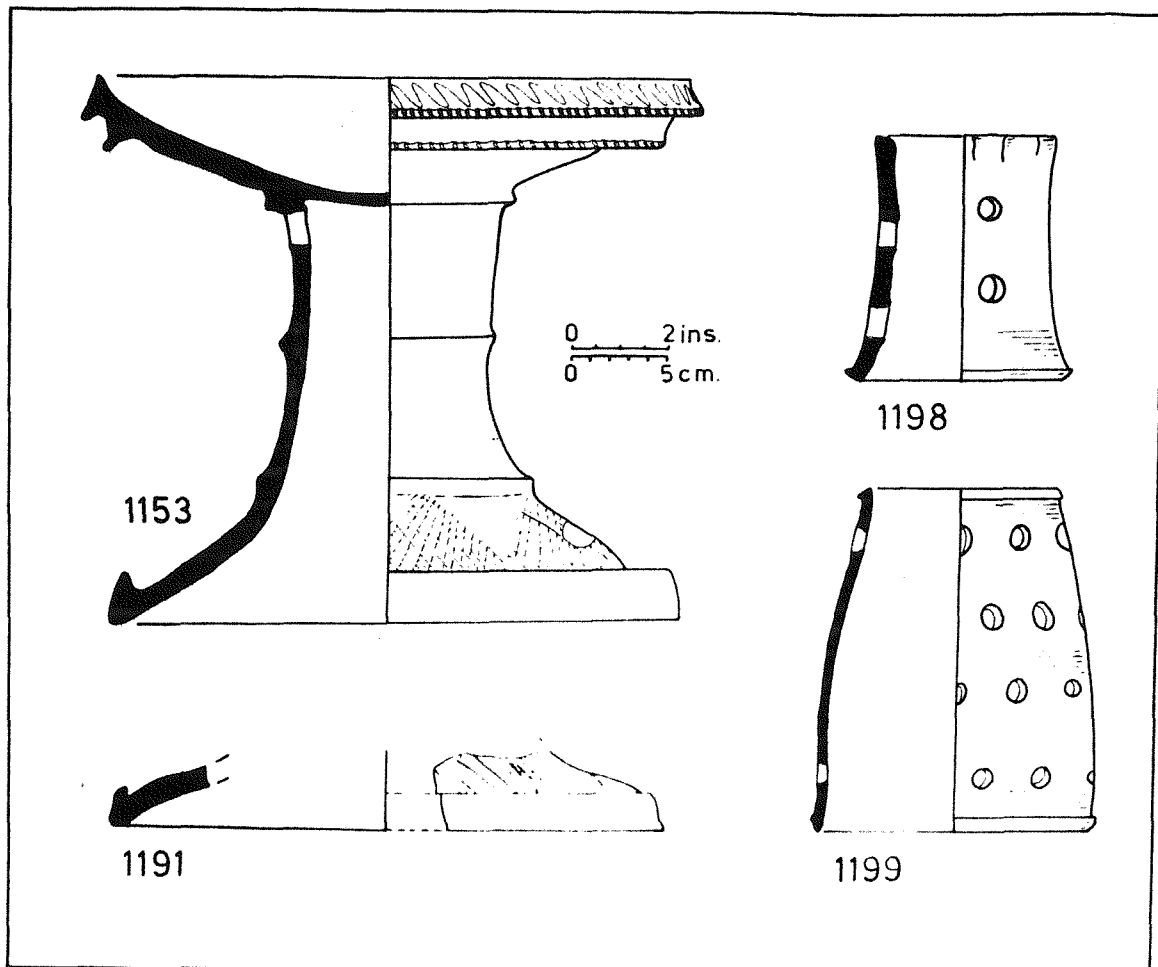

Fig. 8.61 Abu Salabikh: Main Mound, Area E: Pottery samples 1153; 1171; 1198-9. Types 10 and 11; Stemmed dishes and Perforated stands ($\frac{1}{4}$)

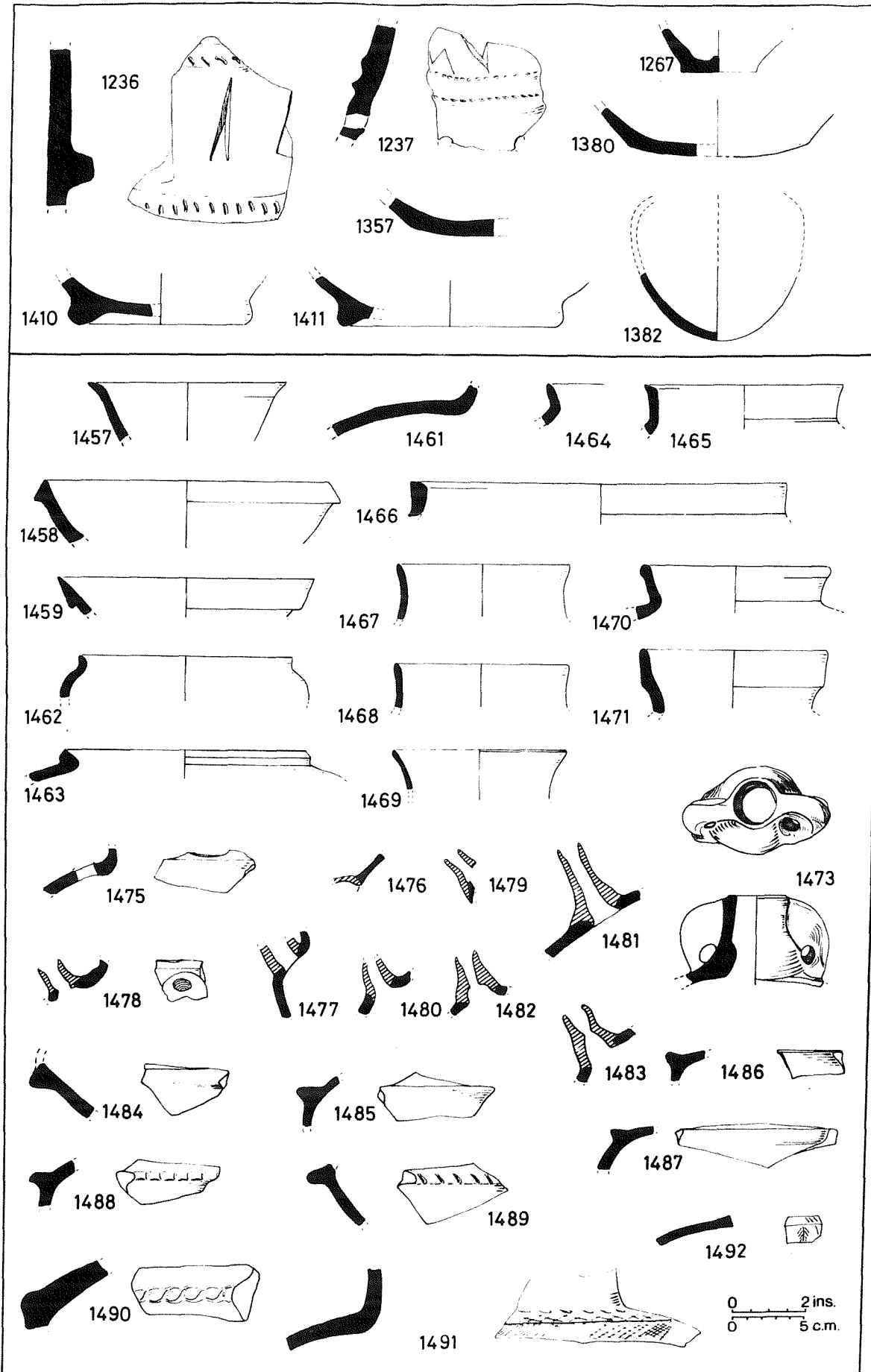

Fig. 8.62 Abu Salabikh: Main Mound, Area E: Pottery samples 1236-1411. Types 11; 14.1; 14.2 and 14.3. Area A: Pottery samples 1457-1491. Types 1.14; 2.4; 5.7; 8 and 9 ($\frac{1}{4}$)

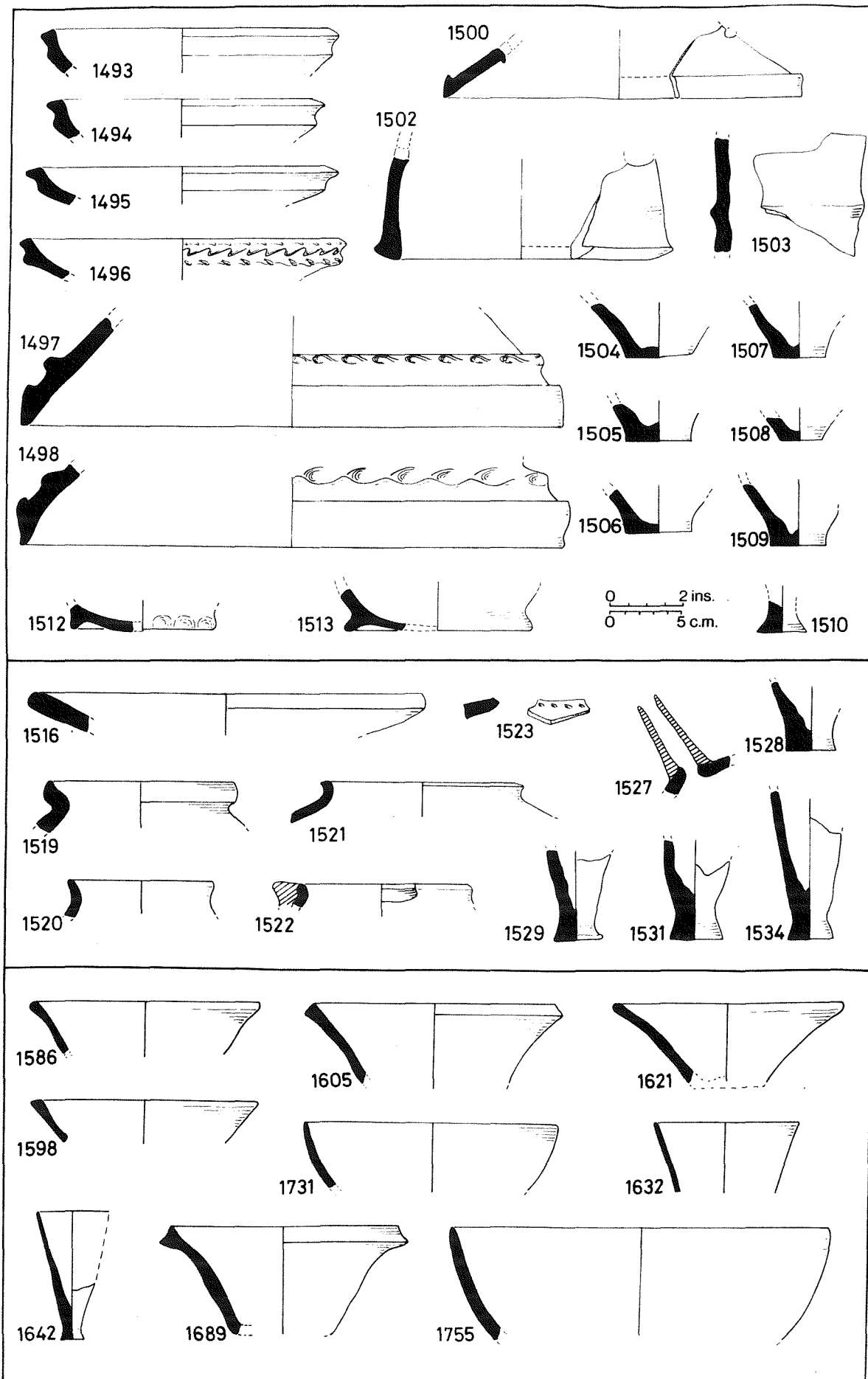

Fig. 8.63 Abu Salabikh: Main Mound, Area A: Pottery samples 1493-1513. North-east mound: Pottery samples 1516-1534. West mound: Pottery samples 1586-1755 (¼)

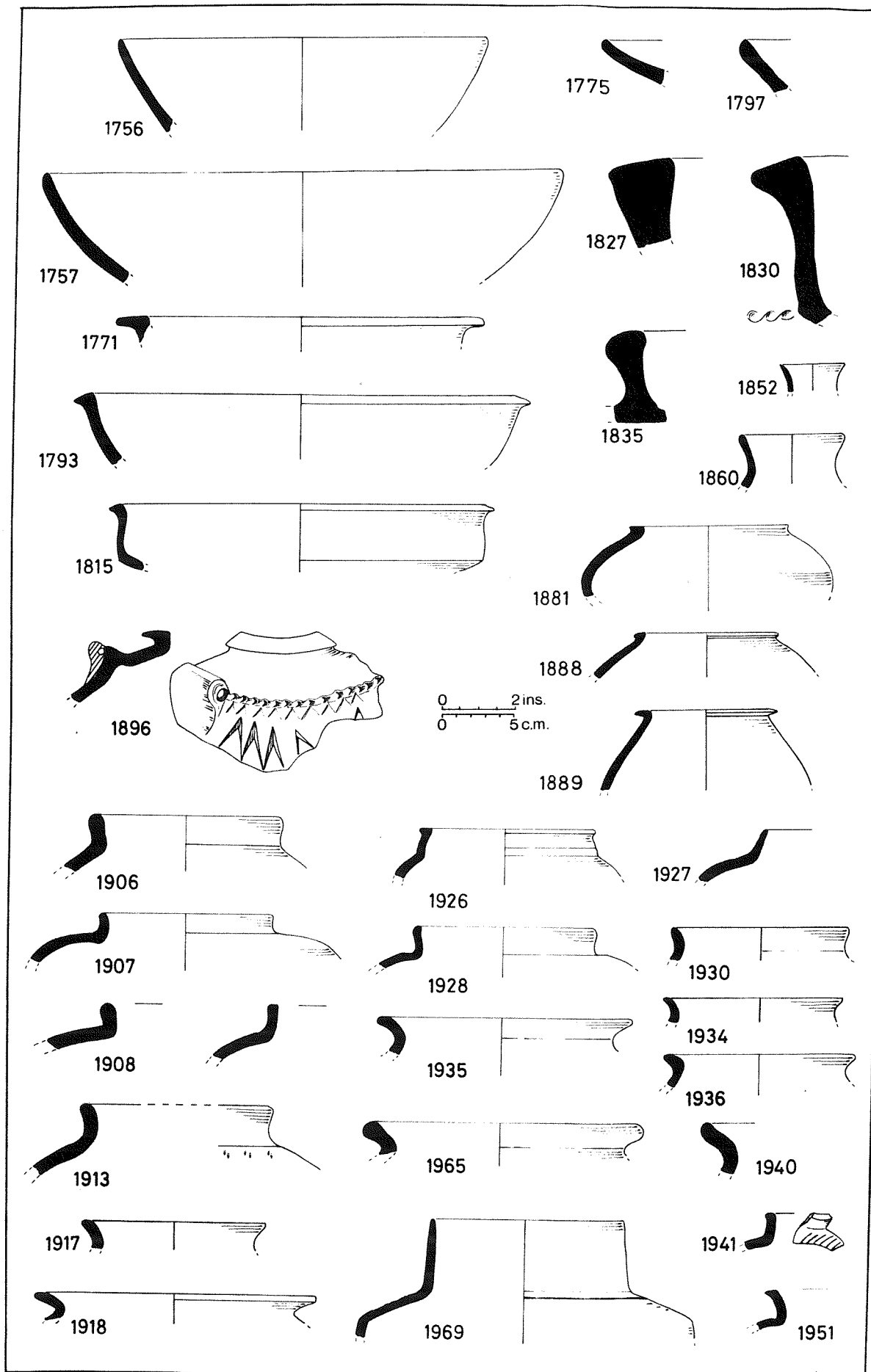

Fig. 8.64 Abu Salabikh: West Mound: Pottery samples 1756-1951. Types 1.14; 1.15 and 2.4 ($\frac{1}{4}$)

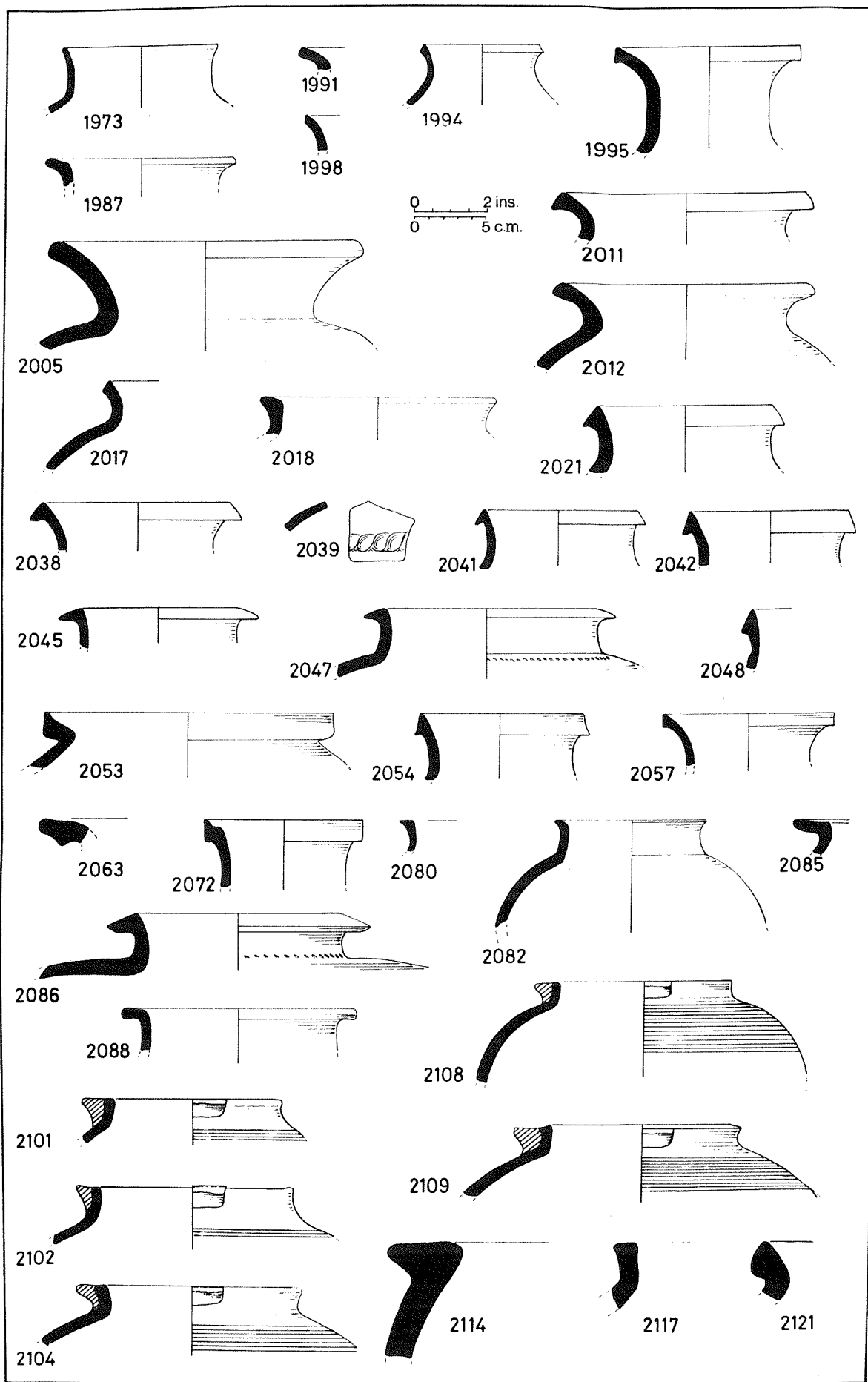

Fig. 8.65 Abu Salabikh: West Mound: Pottery samples 1973-2121. Types 2.4.3 - 2.4.9 ($\frac{1}{4}$)

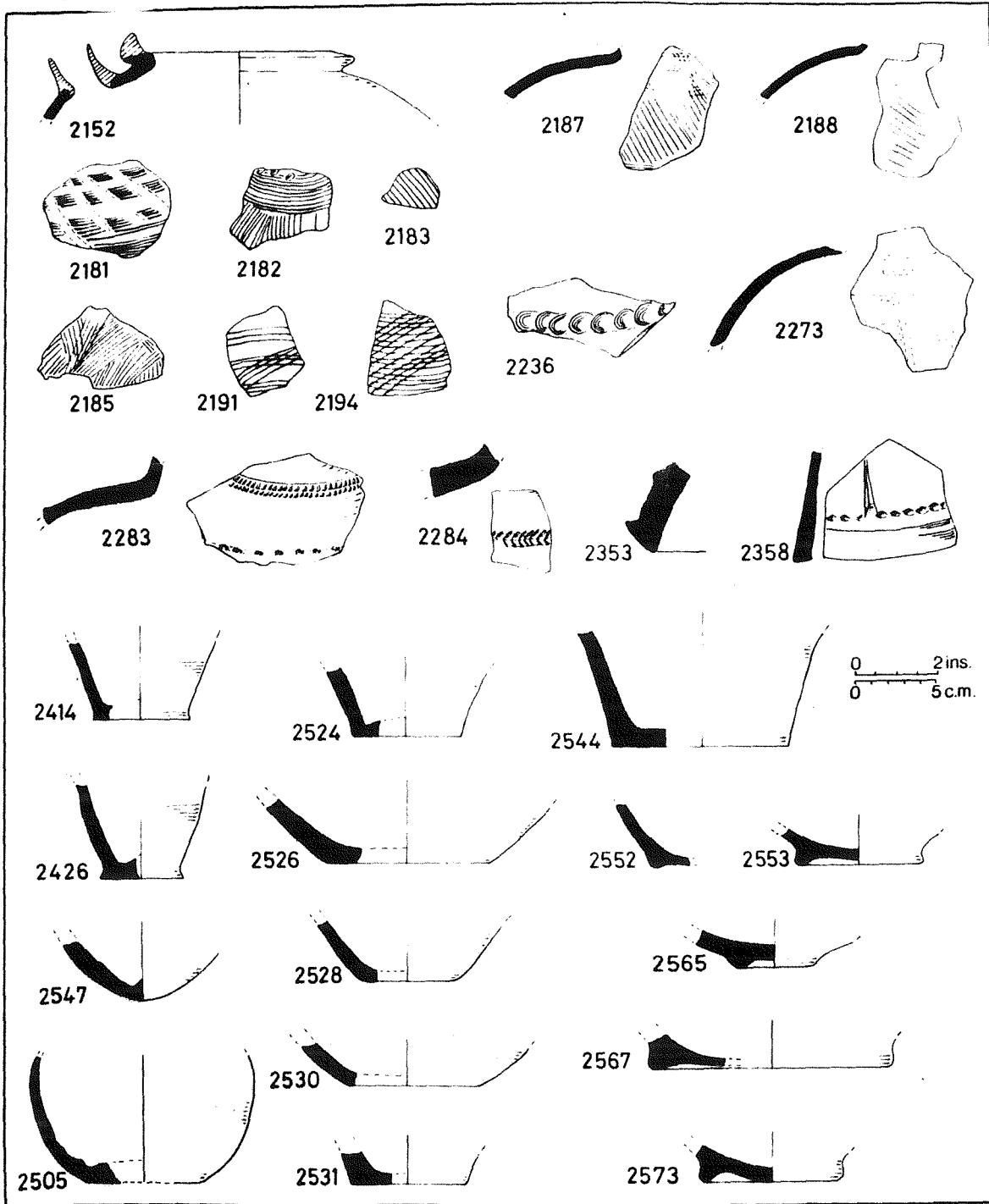

Fig. 8.66 Abu Salabikh: West Mound: Pottery samples 2152-2573. Types 5.7; 8.3; 8.6; 8.9; 8.10; 11; 14.1 and 14.3 (†)

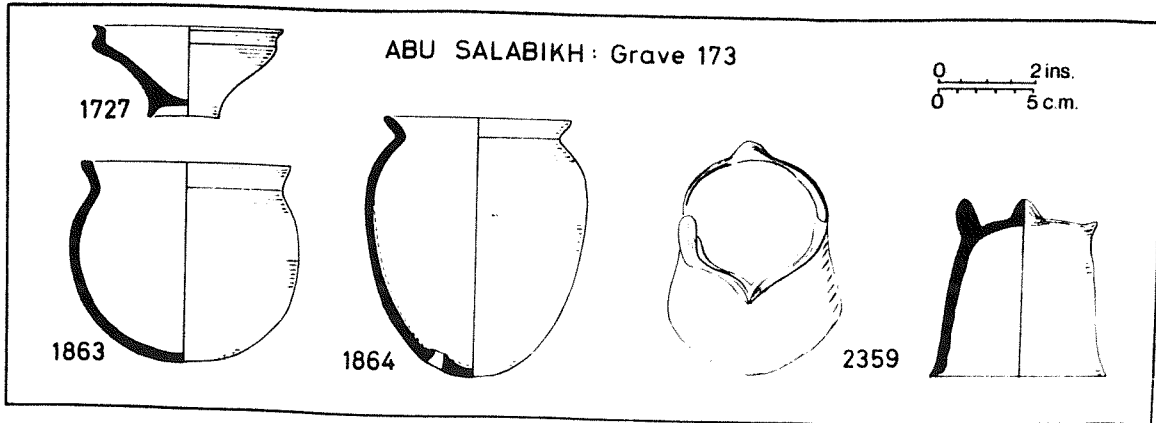

Fig. 8.67 Abu Salabikh: Main Mound, Area E; Grave 173: Pottery samples 1727; 1863; 1864 and 2359. Types 1.7; 2.2; and 11 ($\frac{1}{4}$)

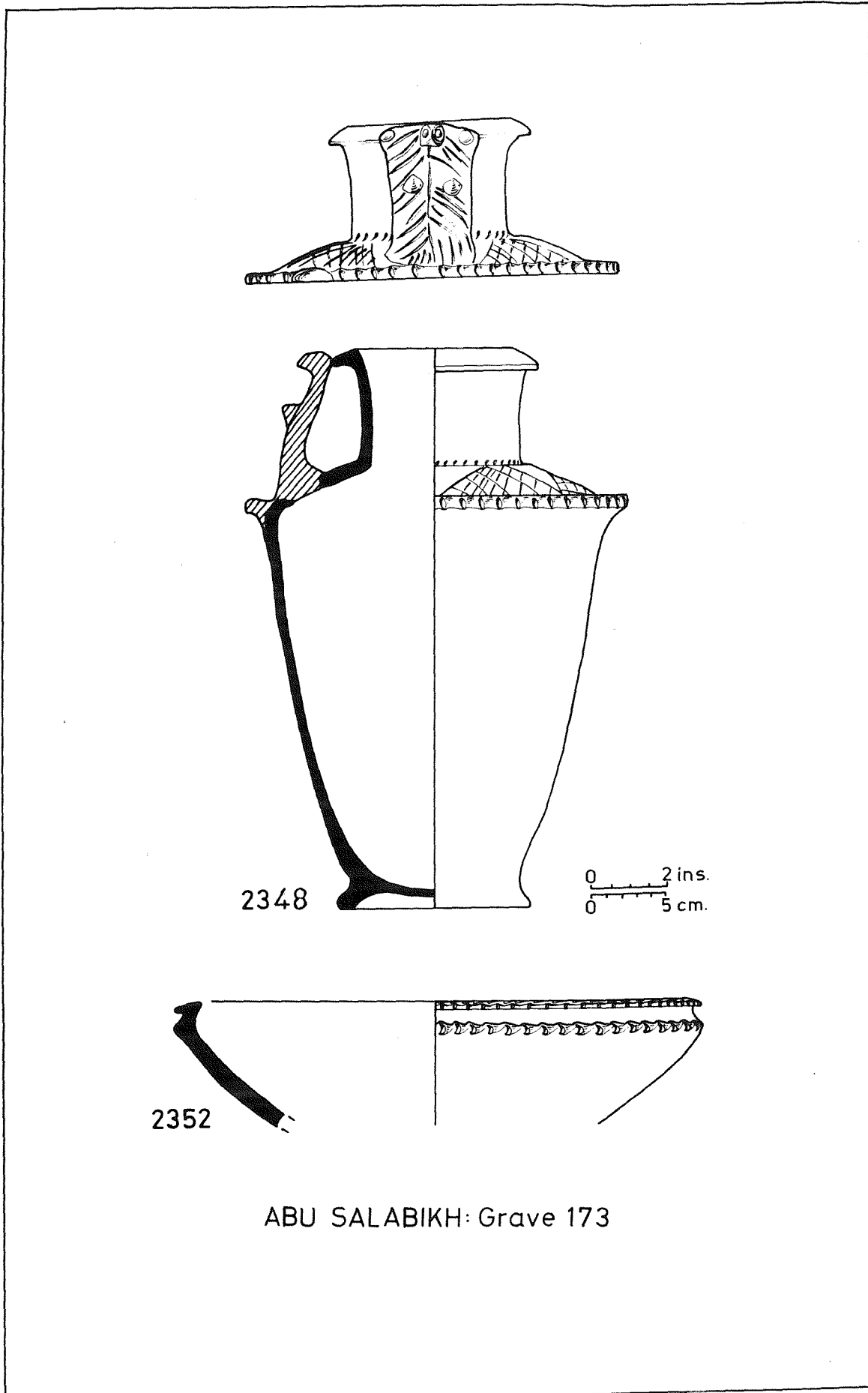

Fig. 8.68 Abu Salabikh: Main Mound, Area E; Grave 173: Pottery samples 2348 and 2352. Types 9 and 10; Upright-handled jar and Stemmed dish ($\frac{1}{4}$)

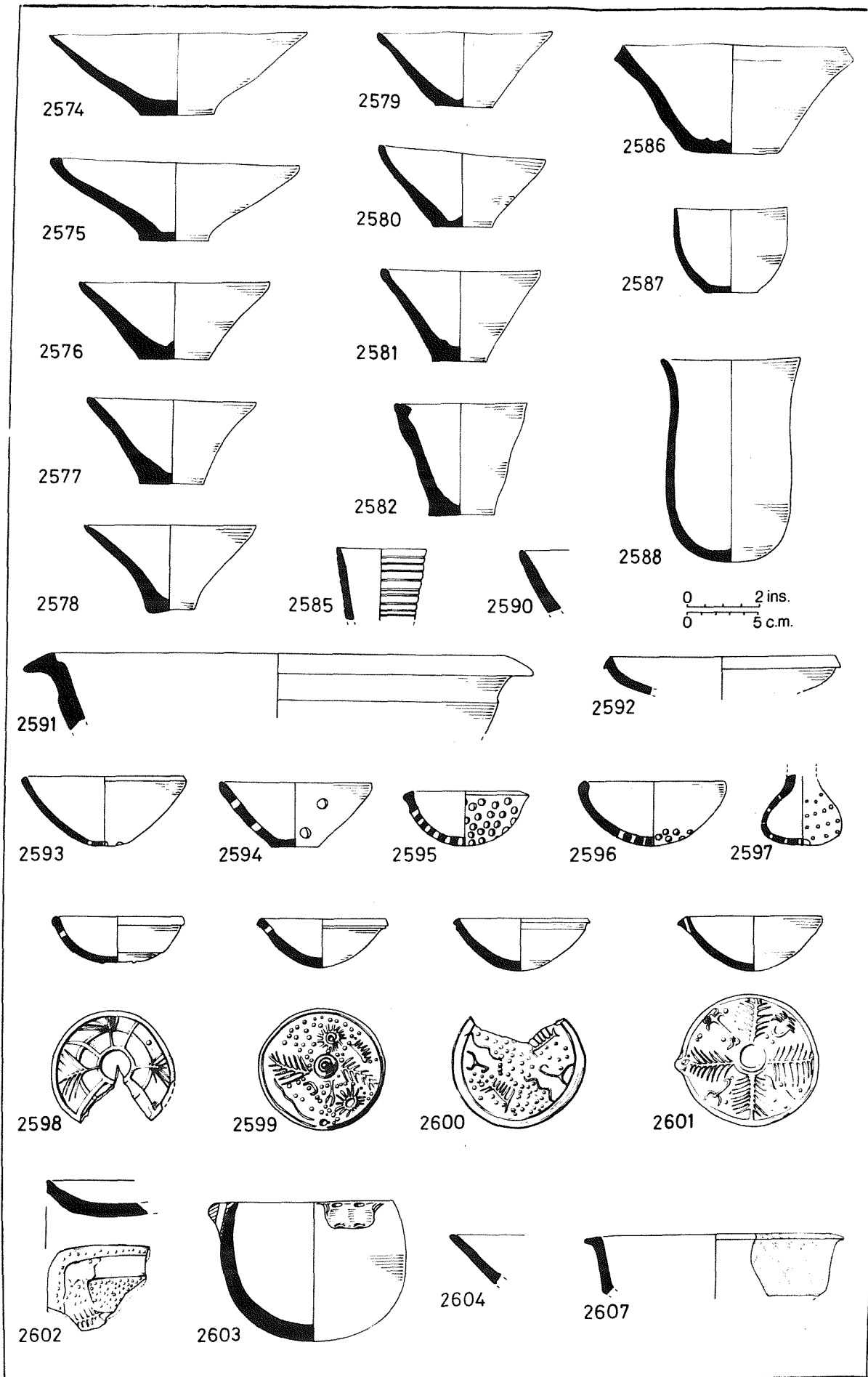

Fig. 8.69 Kish: Pottery samples 2574-2607. Types 1.1; 1.2; 1.3; BRB; 1.4; 1.5; 1.6; 1.9; 1.10; 1.11; 1.12 and 1.13; Bowls ($\frac{1}{4}$)

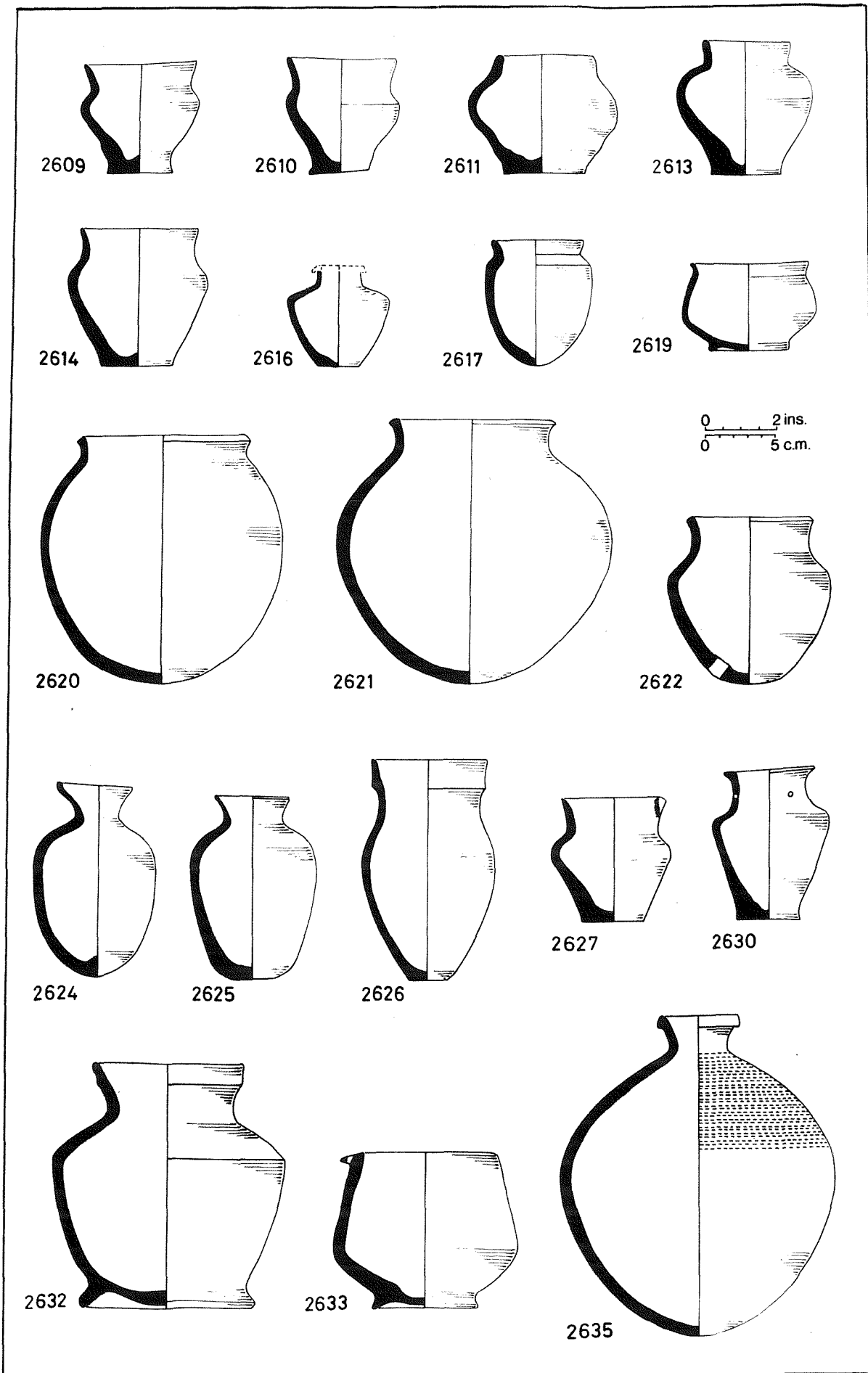

Fig. 8.70 Kish: Pottery samples 2609-2656. Types 2.1; 2.2; and 2.3 (¼)

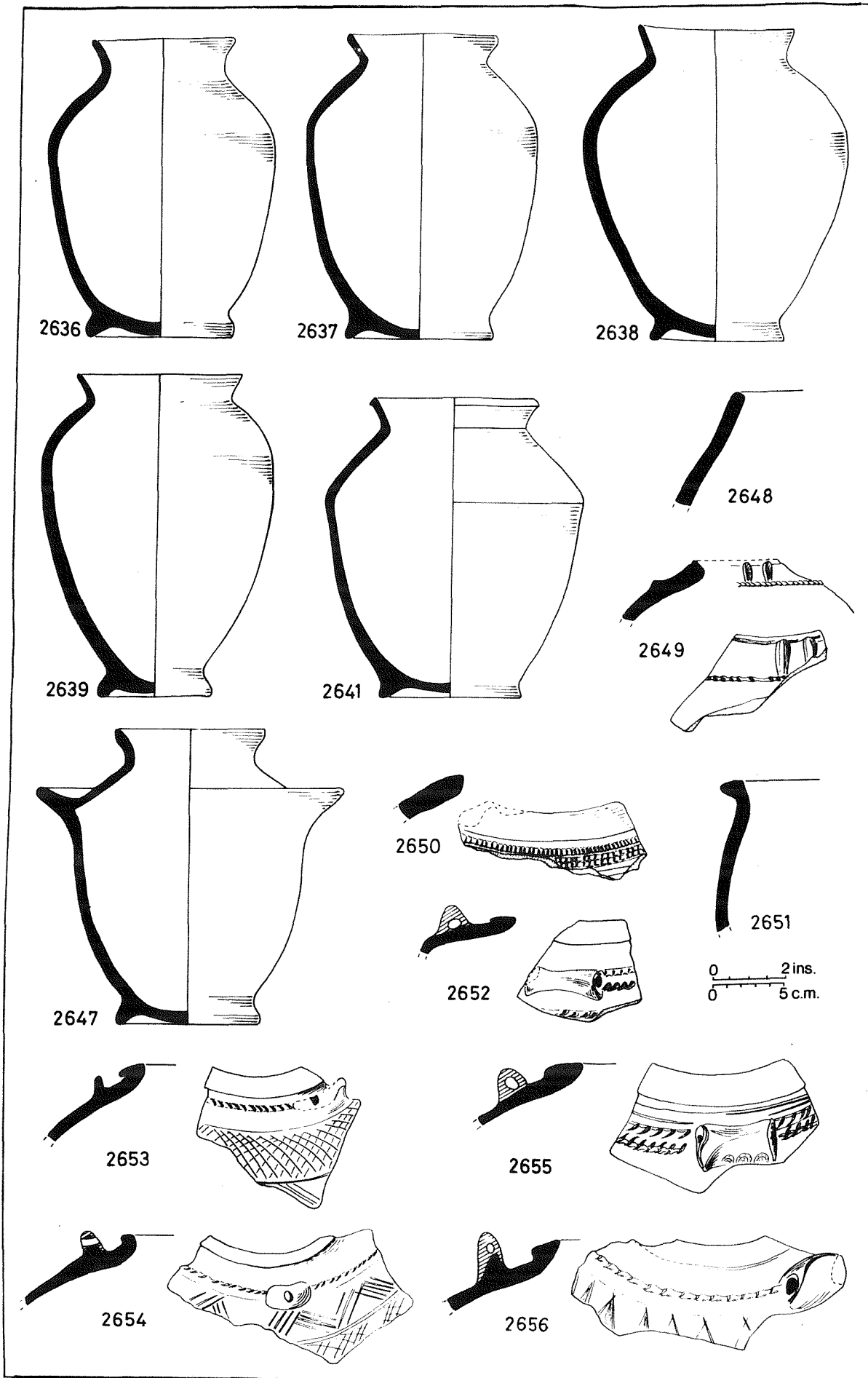

Fig. 8.71 Kish: Pottery samples 2636-2647. Types 2.3.4; Large jars (ring-based) and 2.4.1; Jar rim sherds ($\frac{1}{4}$)

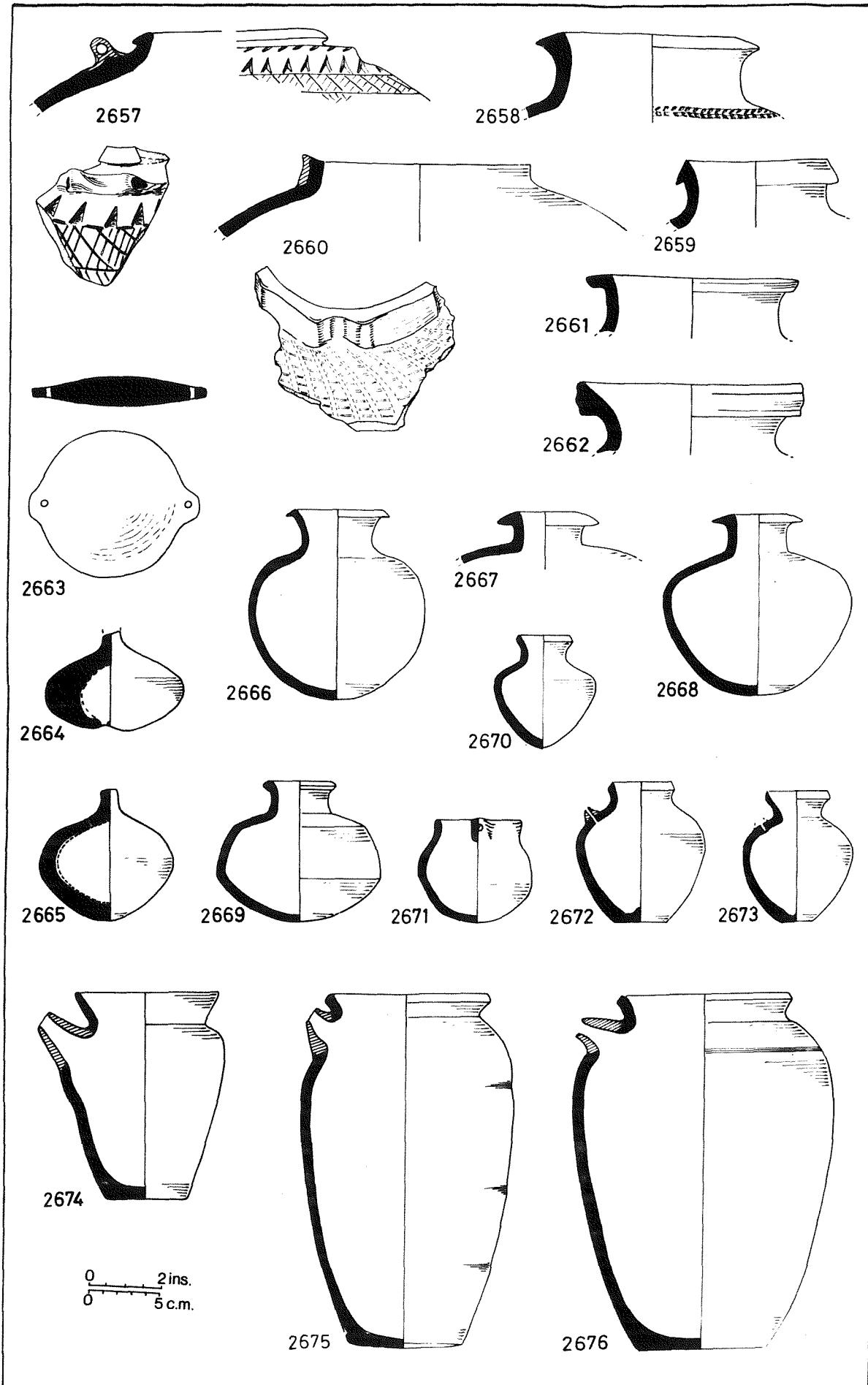

Fig. 8.72 Kish: Pottery samples 2657-2676. Types 2.4; 2.6; 3.2; 3.6; 4.1; and 5.1; Jar rim sherds, Lids, Bottles and Spouted jars ($\frac{1}{4}$)

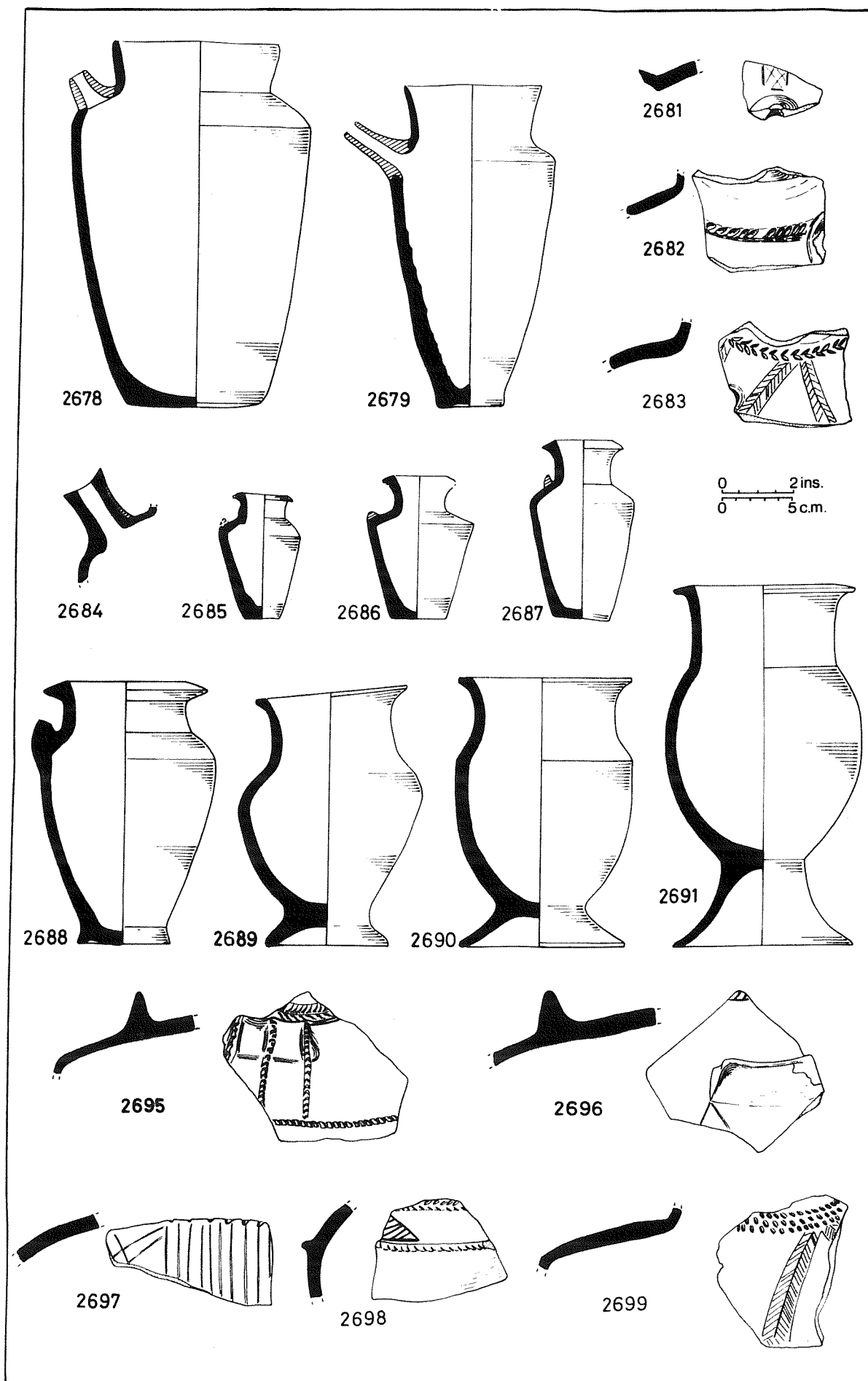

Fig. 8.73 Kish: Pottery samples 2678-2699. Types 5.2; 5.3; 5.7; 6.1; 6.2; 7.1; 8.4; and 8.5; Spouted jars, Wing-lugged jars, Footed jars and L.Uruk/ED I decorated body sherds ($\frac{1}{4}$)

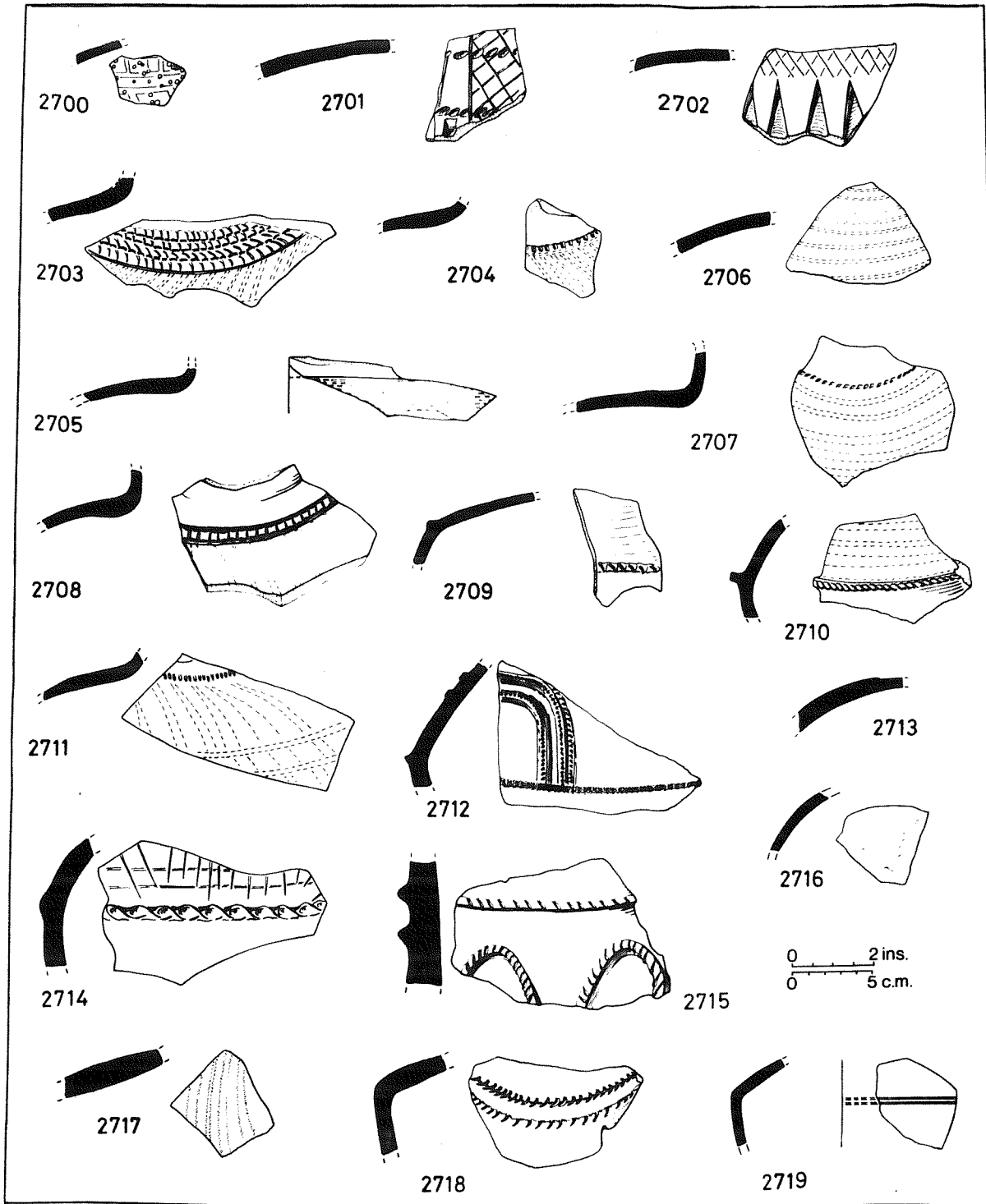

Fig. 8.74 Kish: Pottery samples 2700-2719. Types 8.6; 8.7; 8.9; 8.13; 8.16; 8.17 and 8.20; L.Uruk/ED I decorated body sherds ($\frac{1}{4}$)

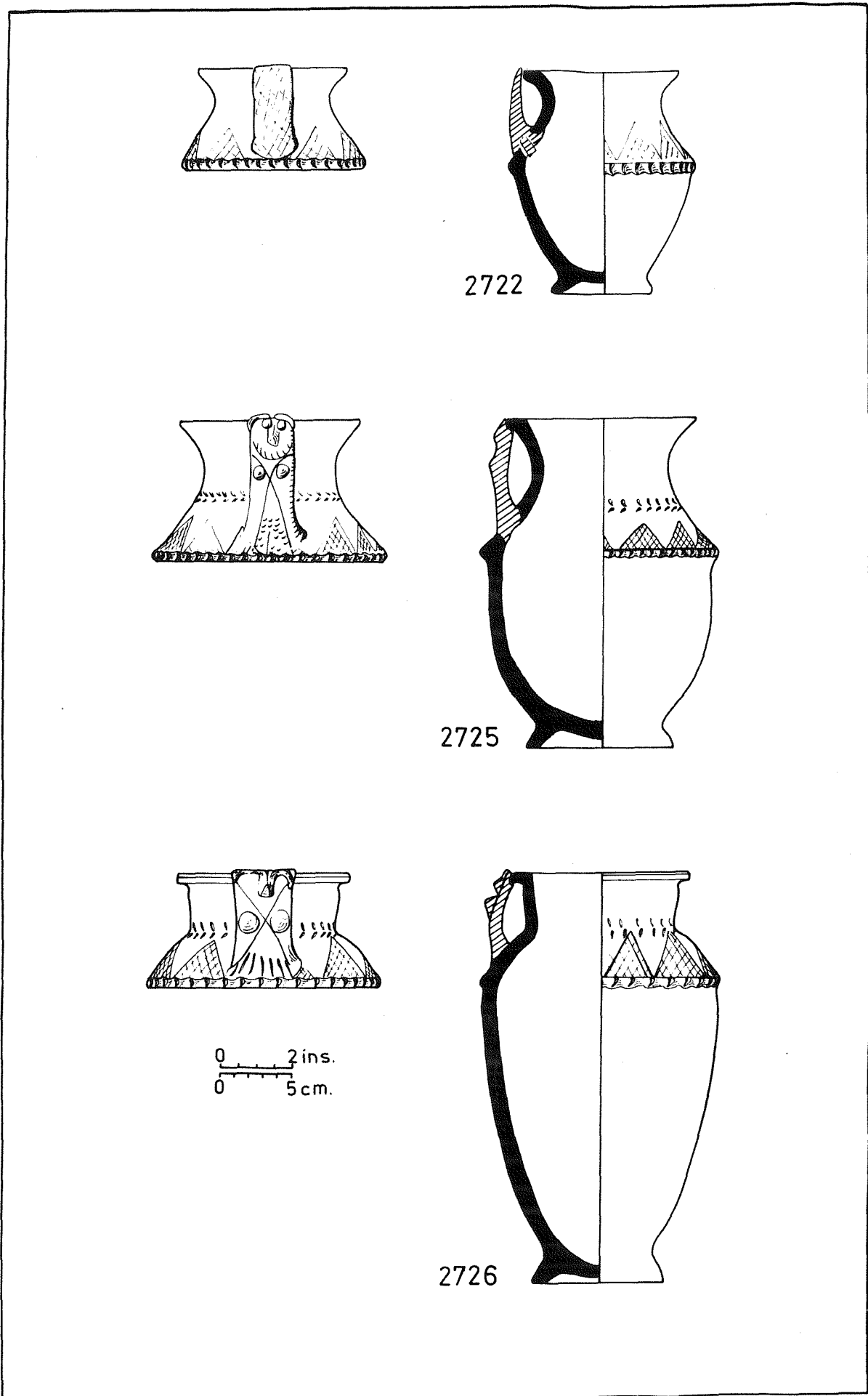

Fig. 8.75 Kish: Pottery samples 2722-2726. Type 9; Upright-handled jars ($\frac{1}{4}$)

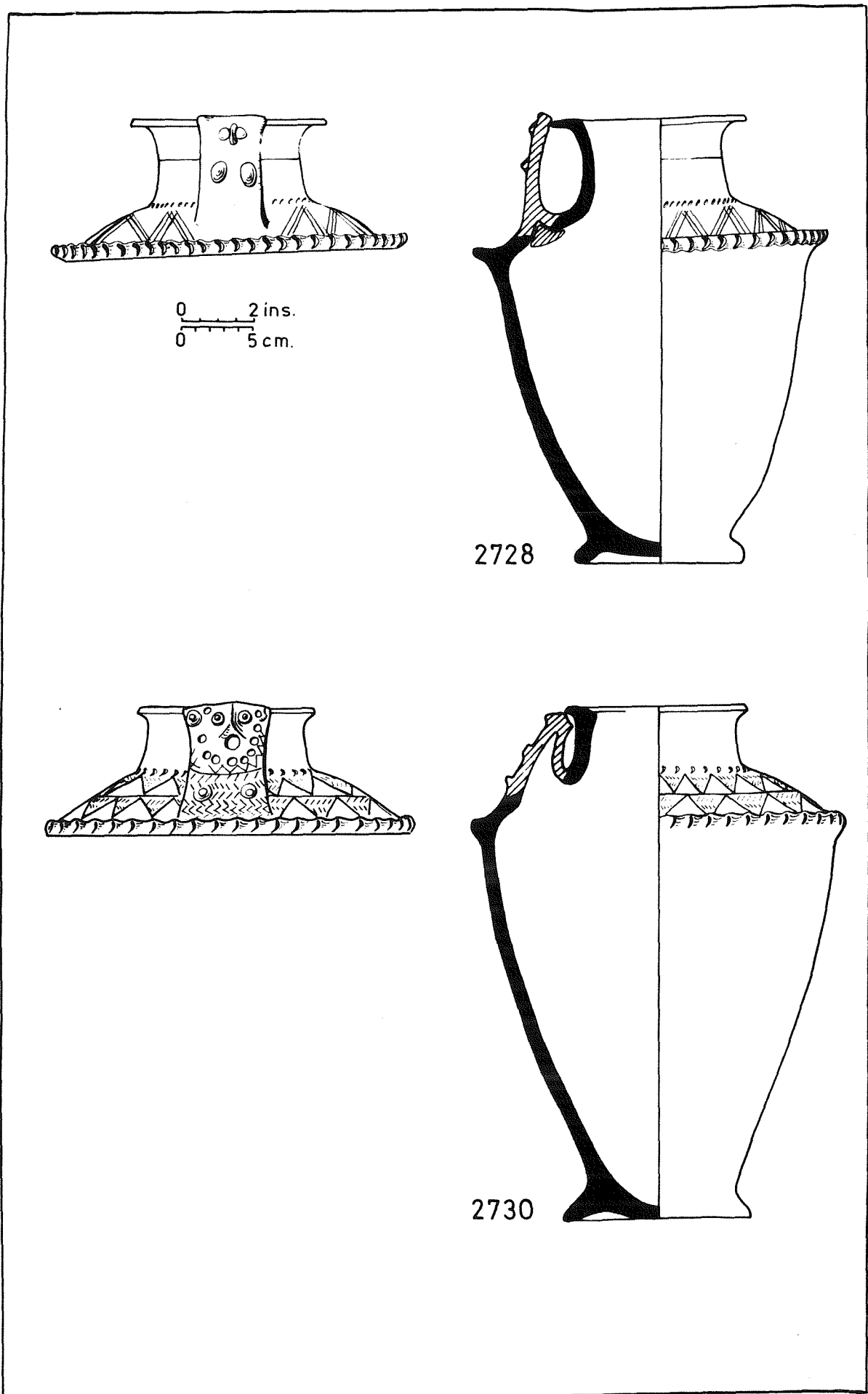

Fig. 8.76 Kish: Pottery samples 2728-2730. Type 9; Upright-handled jars ($\frac{1}{4}$)

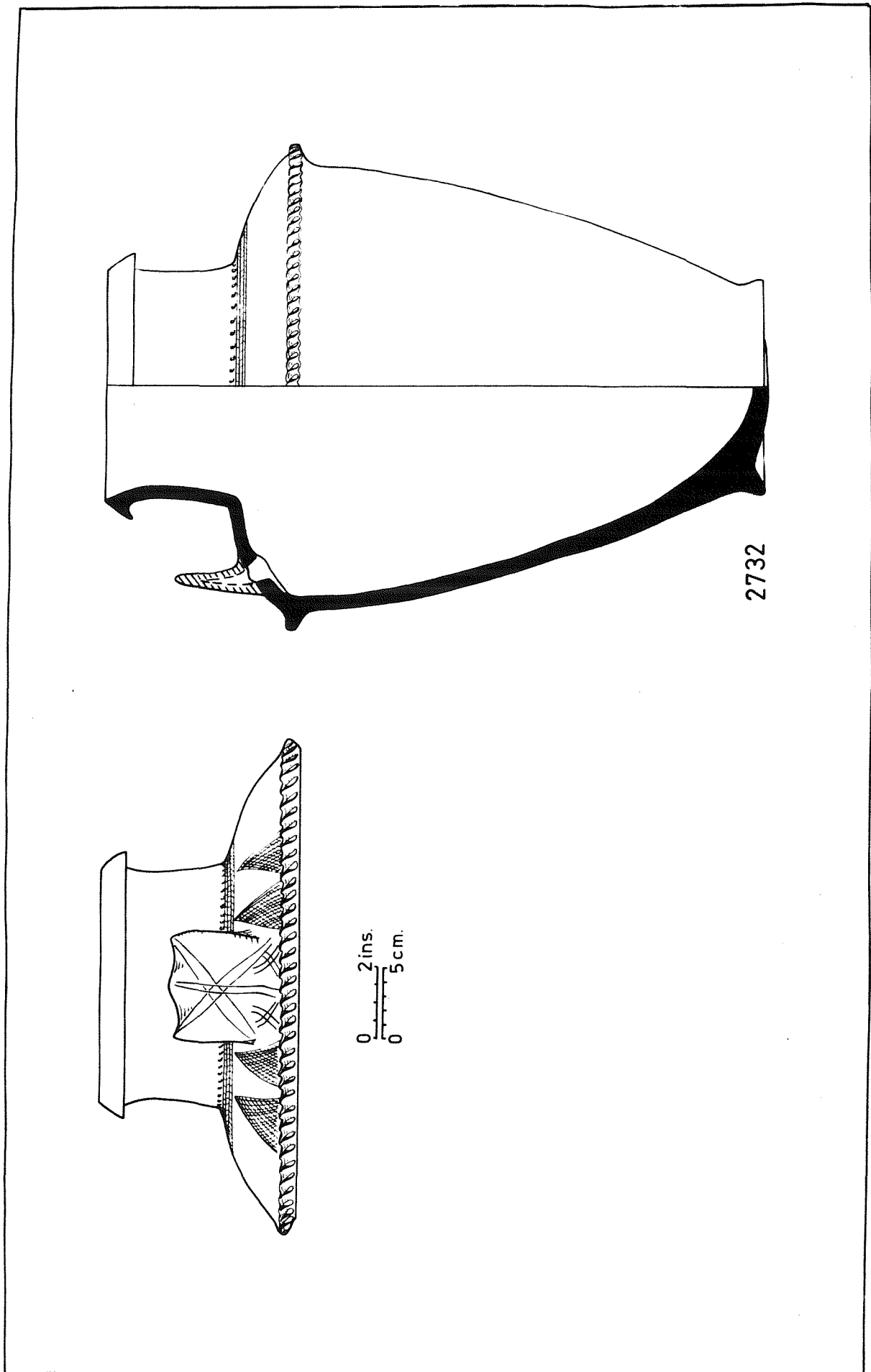

Fig. 8.77 Kish: Pottery samples 2732. Type 9; Upright-handled jar
($\frac{1}{4}$)

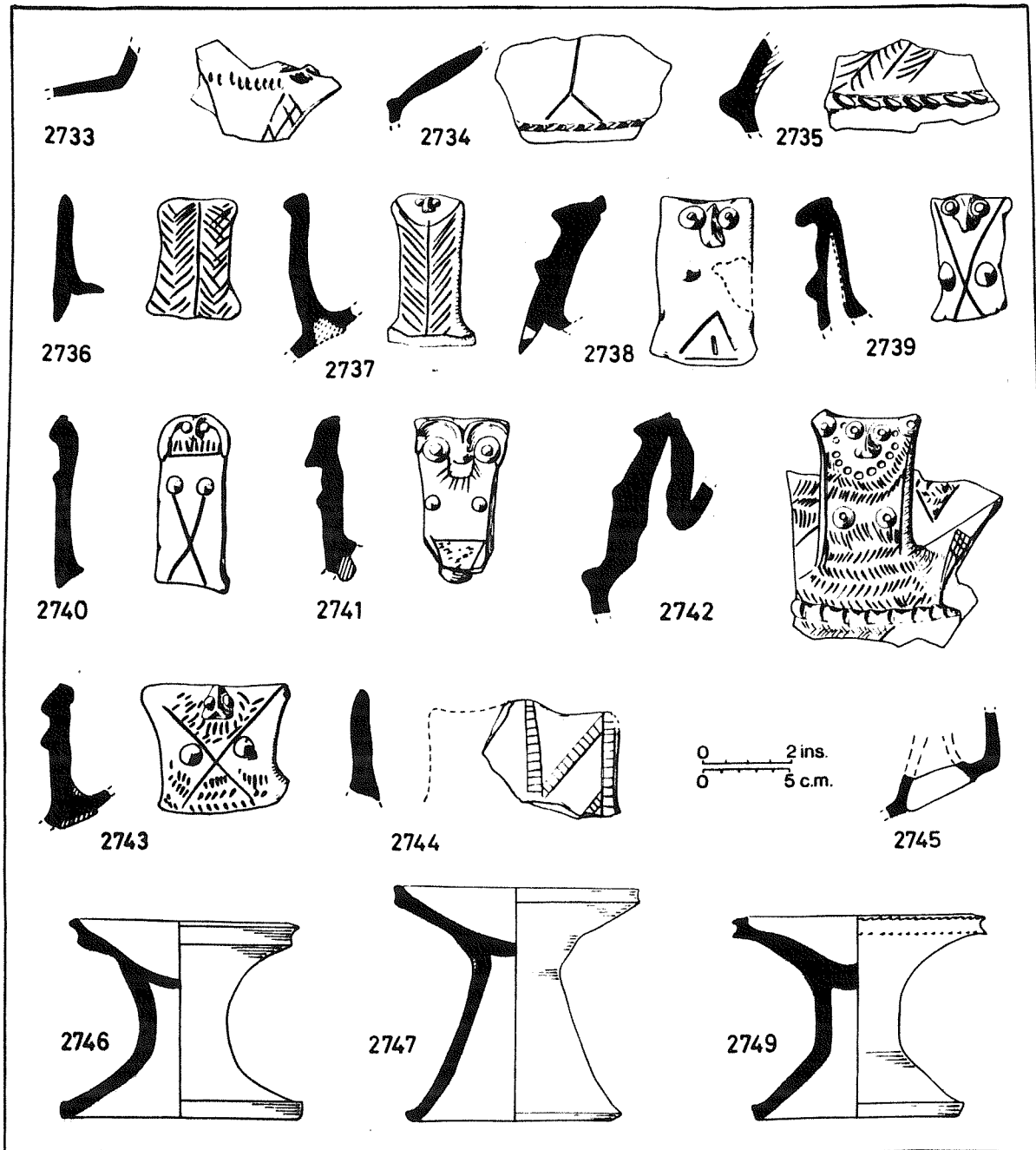

Fig. 8.78 Kish: Pottery samples 2733-2749. Type 9; 9.1 and 10; Upright-handled jar sherds and handles and Stemmed dishes ($\frac{1}{4}$)

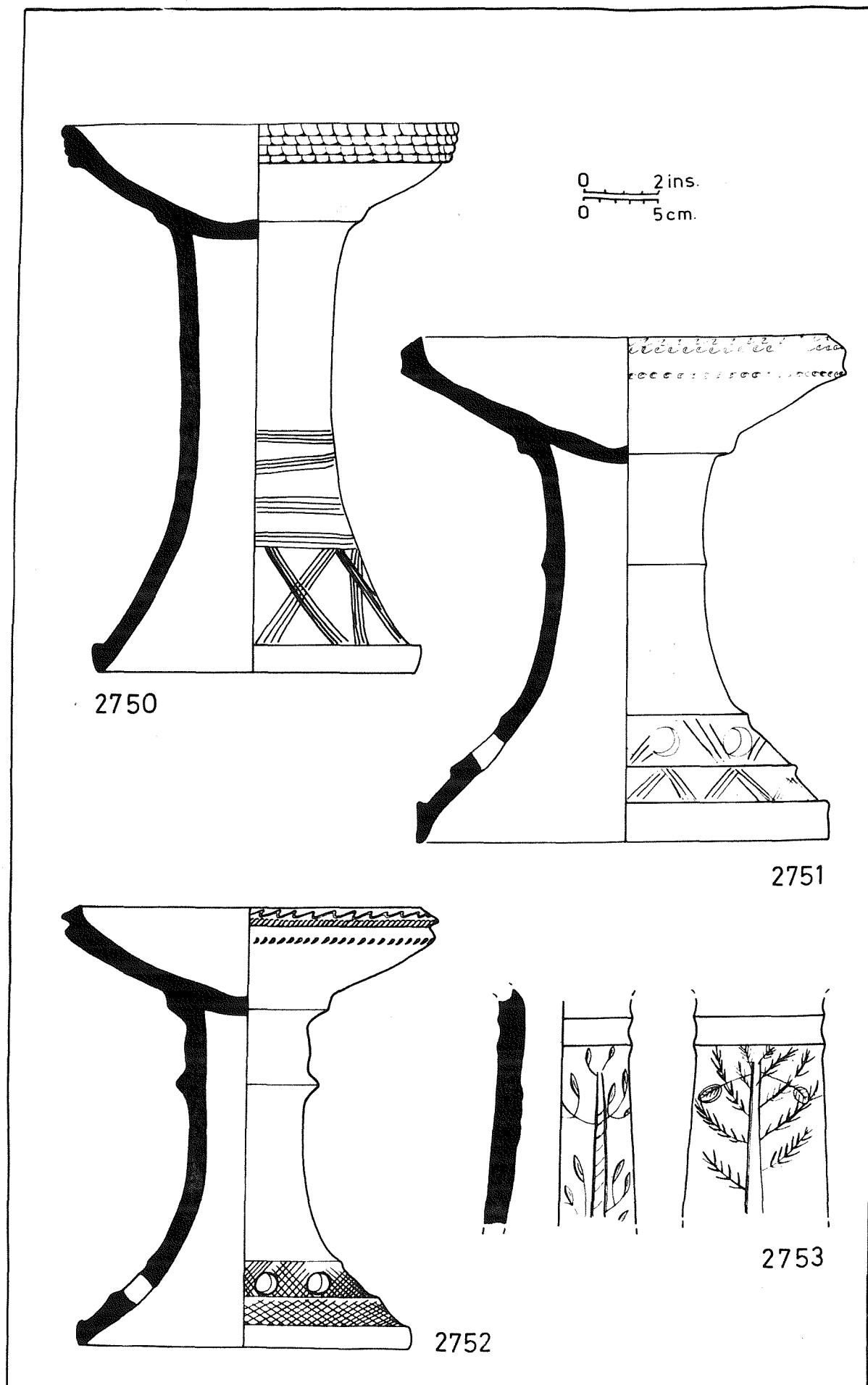

Fig. 8.79 Kish: Pottery samples 2750-2753. Type 10; Stemmed dishes
($\frac{1}{2}$)

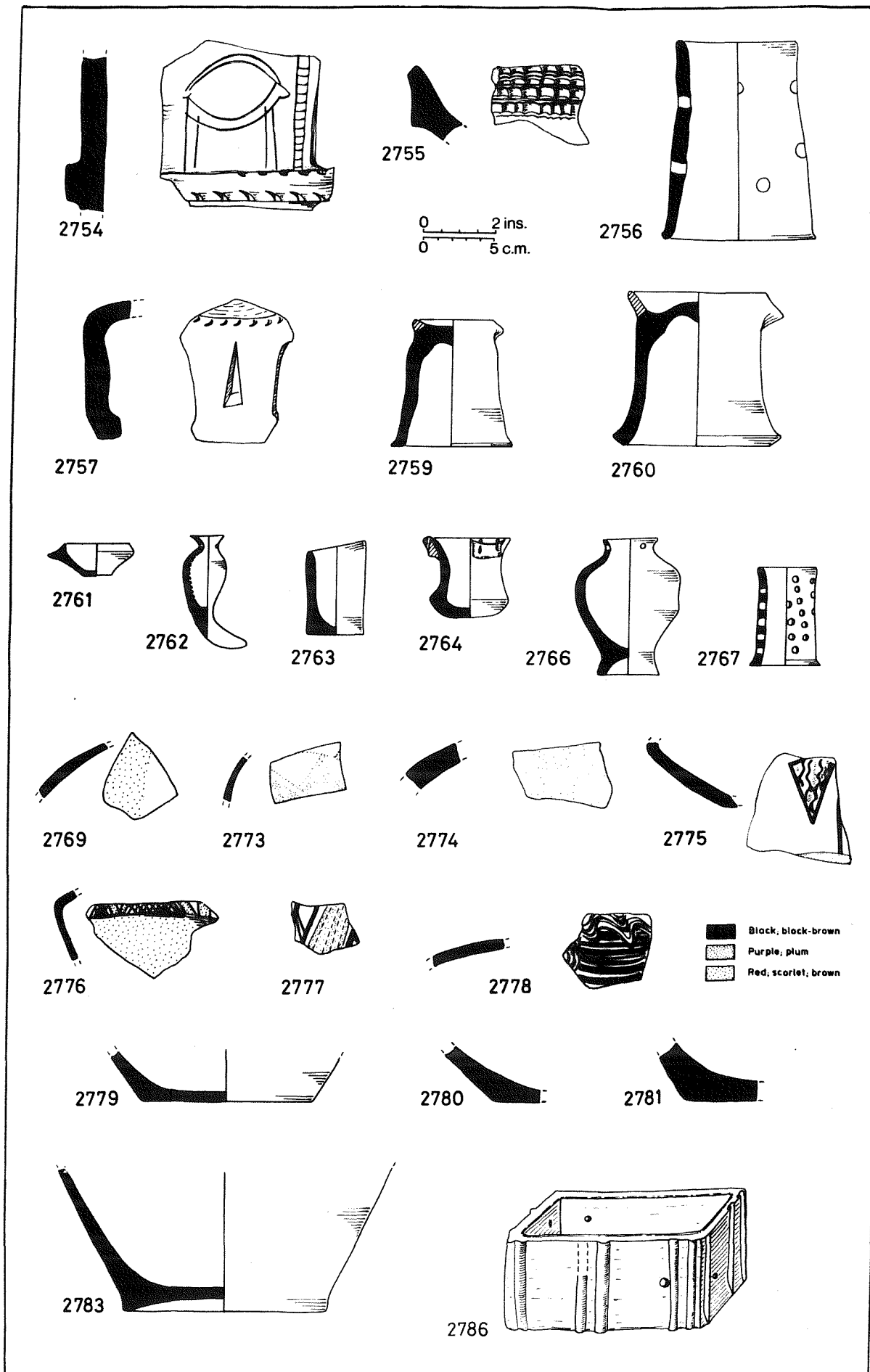

Fig. 8.80 Kish: Pottery samples 2754-2786. Types 10.5; 10.7; 11.1; 11.4?; 11.9; 12.1; 12.2; 12.3; 12.4; 12.5; 13.1; 13.2; 14.1; 14.3 and a clay cist ($\frac{1}{4}$)

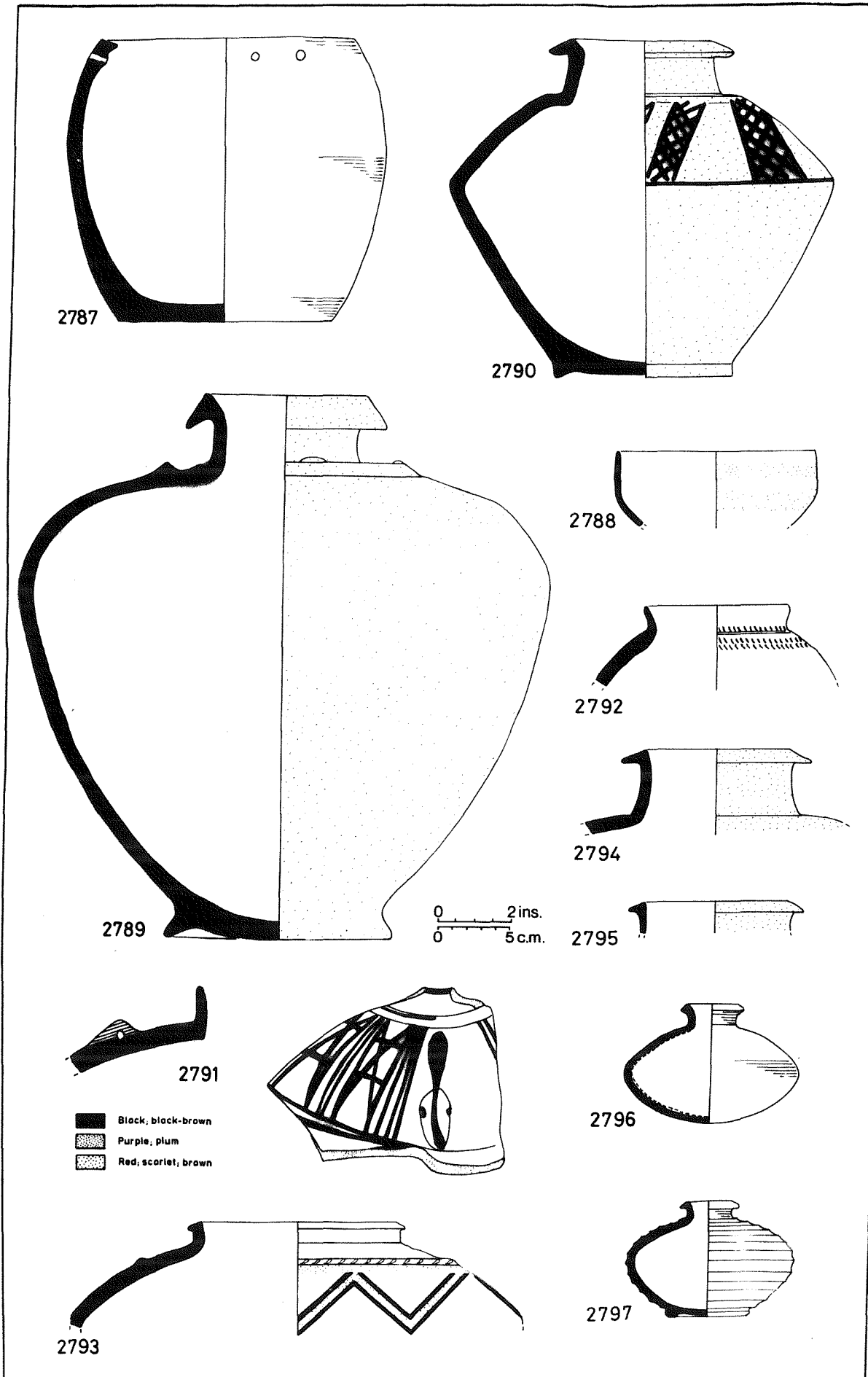

Fig. 8.81 Jamdat Nasr: Pottery samples 2787-2797. Types 1.11; 1.14; 2.3; 2.4; 3.1 and 3.7 ($\frac{1}{4}$)

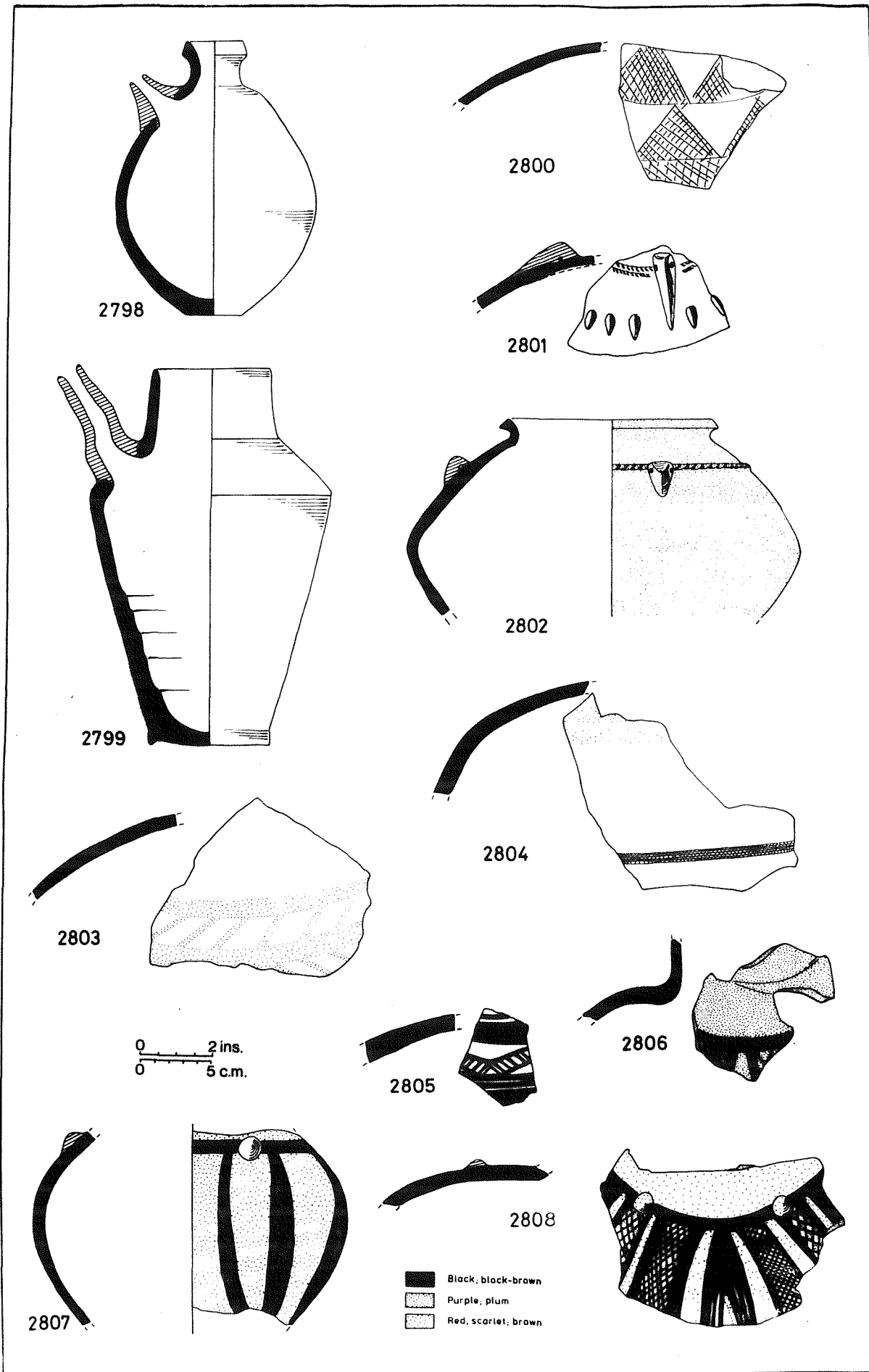

Fig. 8.82 Jamdat Nasr: Pottery samples 2798-2808. Types 5.1; 5.4; 8.5; 13.1; and 13.2; Spouted jars and polychrome painted ware ($\frac{1}{4}$)

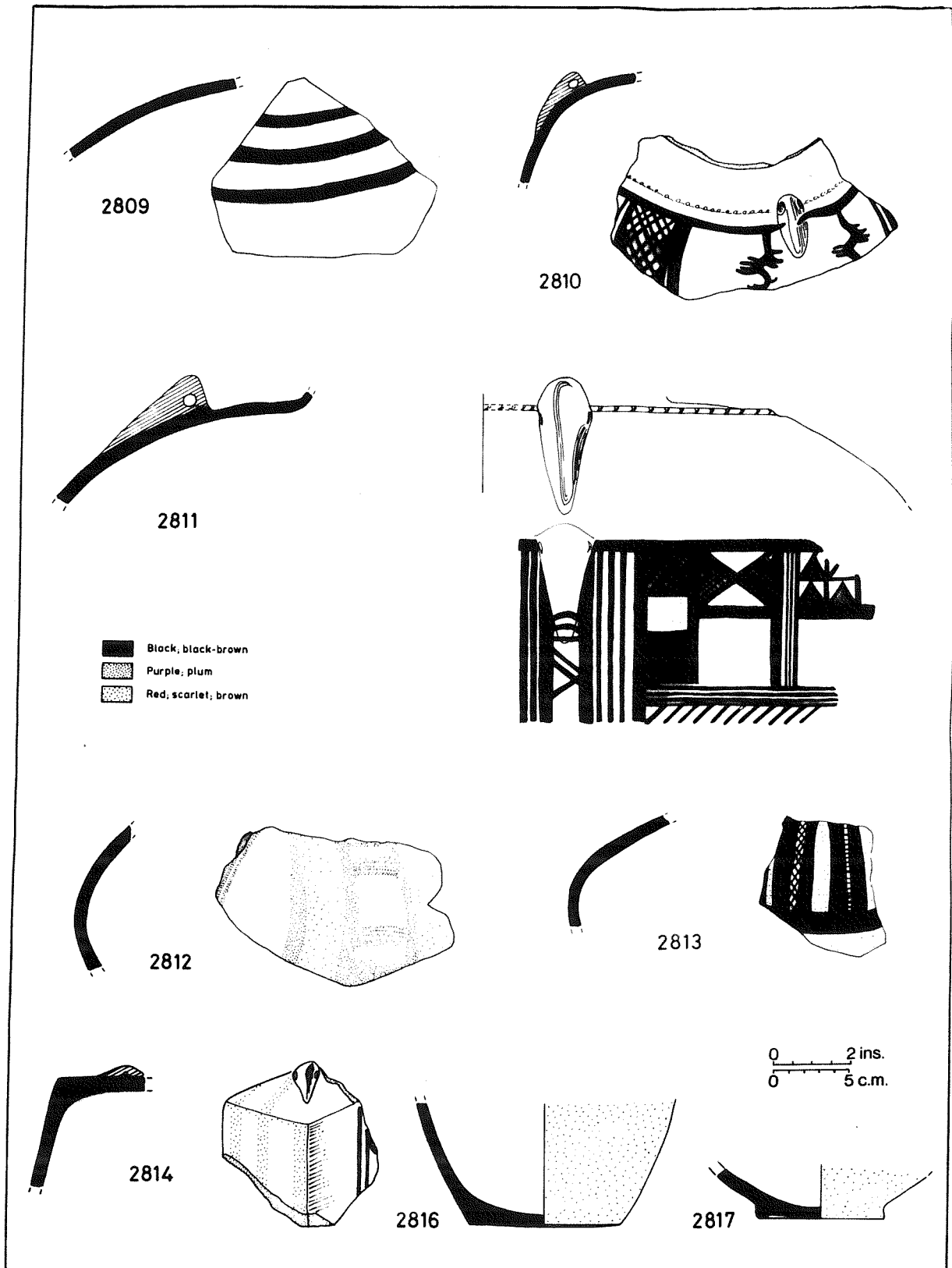

Fig. 8.83 Jamdat Nasr: Pottery samples 2809-2817. Types 13.2; 14.1 and 14.3; polychrome painted ware ($\frac{1}{4}$)

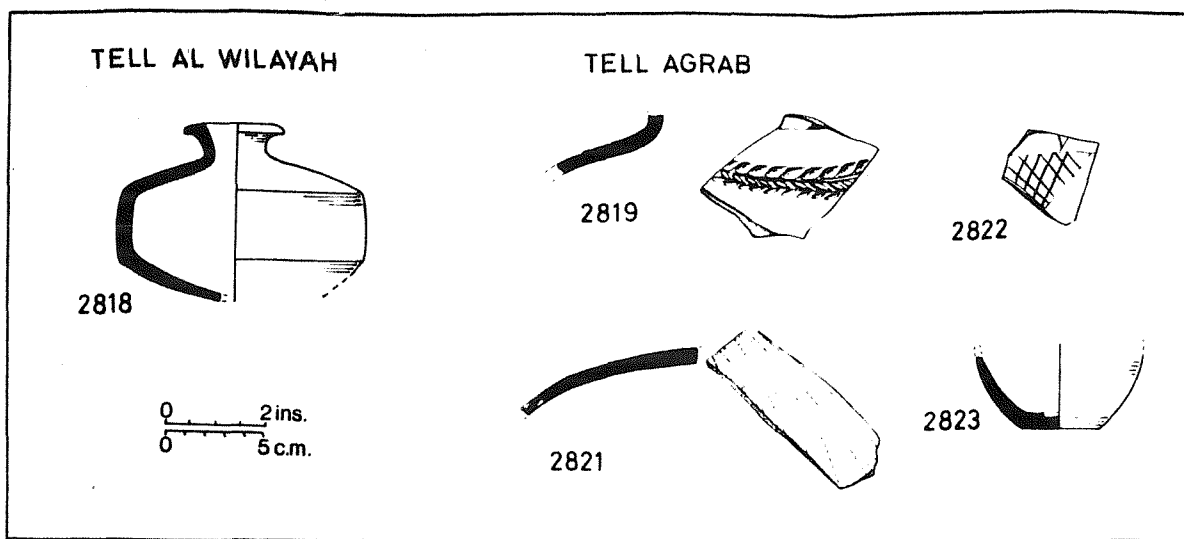

Fig. 8.84 Tell al Wilayah: Pottery sample 2818. Type 3; Bottle.
Tell Agrab: Pottery samples 2819-2823. Type 8.6; 8.9; 9?
and 14.1; Decorated body sherds and a flat base (‡)

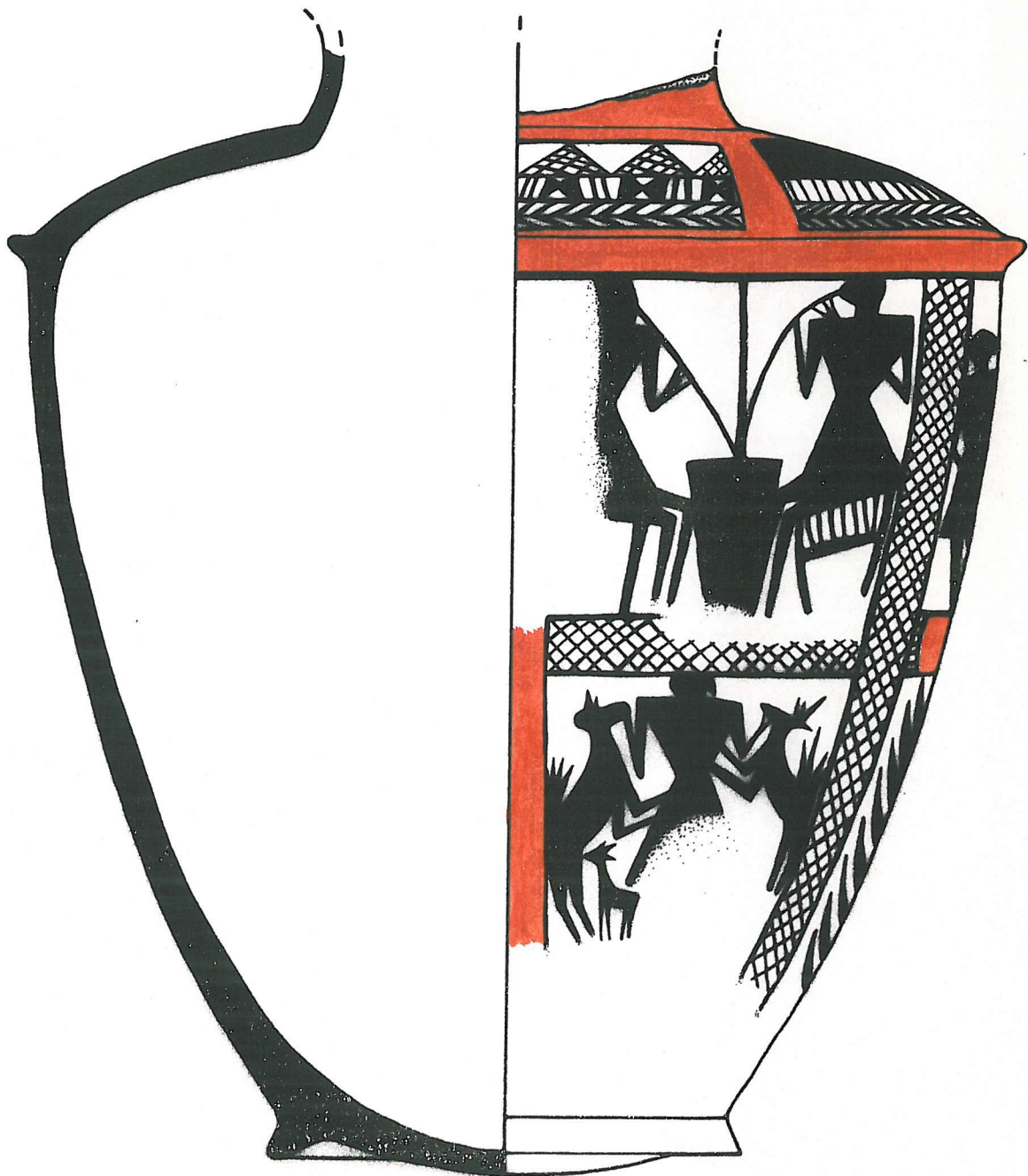

Fig. 8.85 Khafajah: Pottery sample 2825. View 1: Drinking scene ($\frac{1}{4}$)

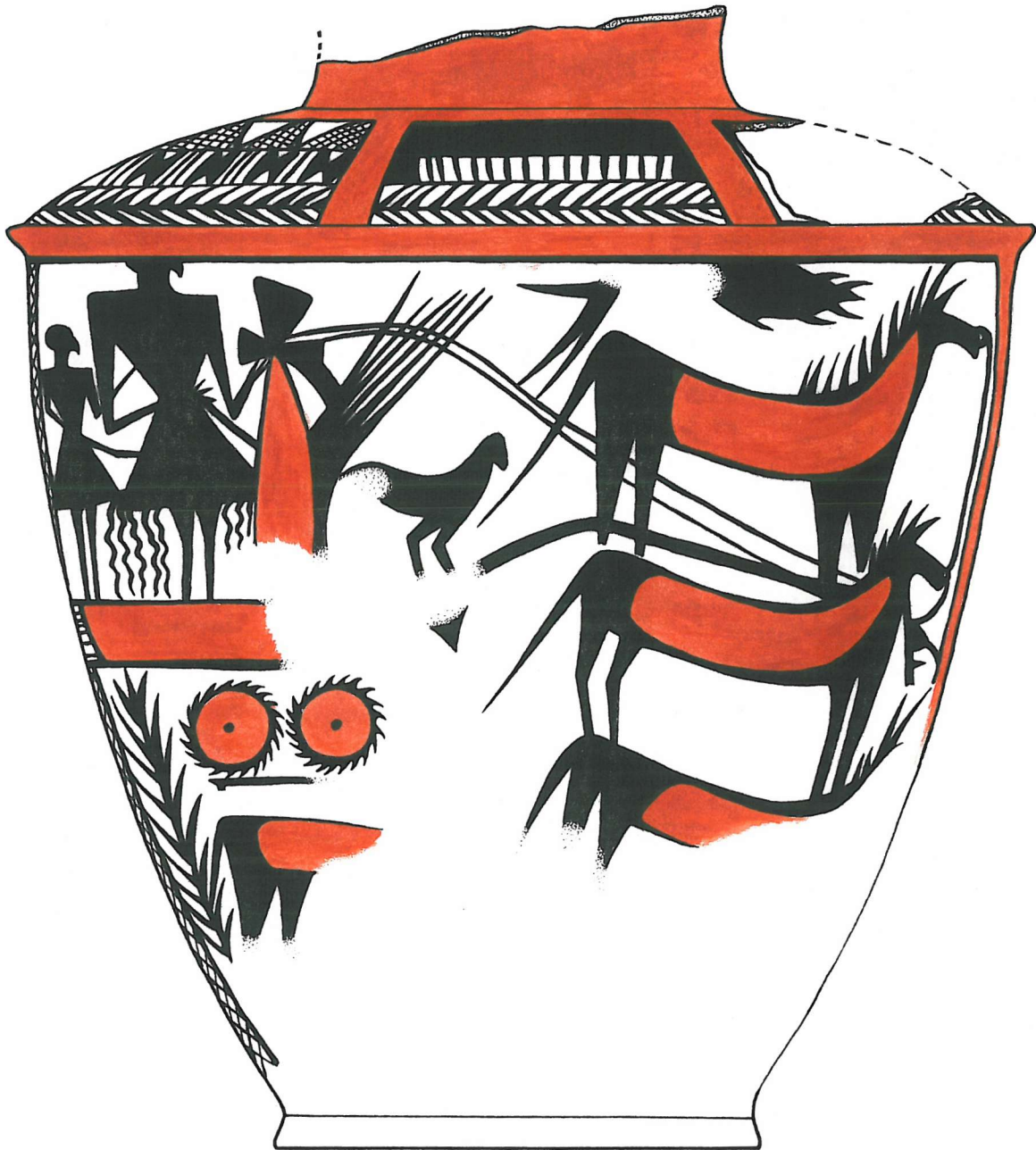

Fig. 8.86 Khafajah: Pottery sample 2825. View 2: Chariot scene ($\frac{1}{4}$)



Fig. 8.87 Khafajah: Pottery sample 2825. View 3: Hunting scene ($\frac{1}{4}$)



Fig. 8.88 Khafajah: Pottery sample 2825. View 4: Milking scene ($\frac{1}{4}$)

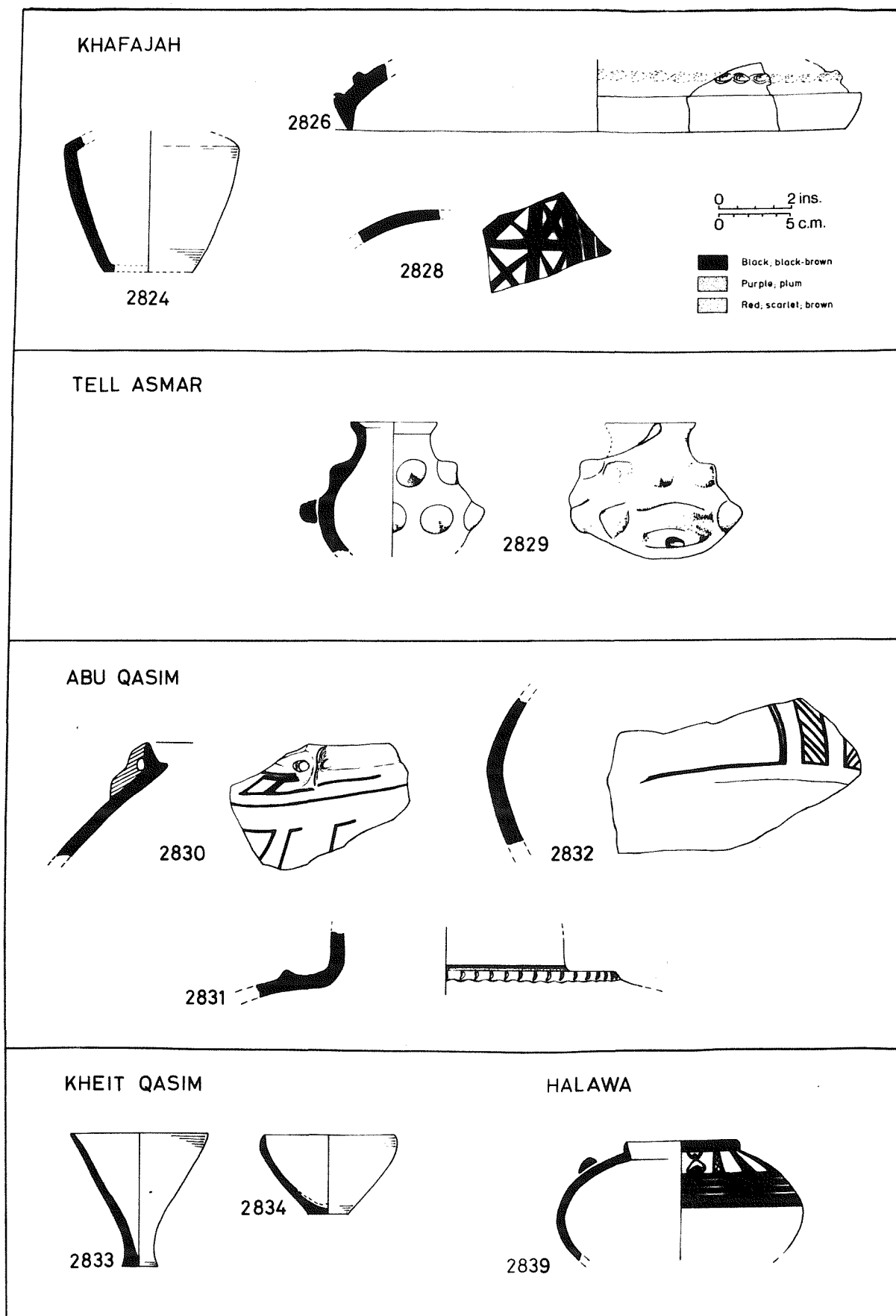

Fig. 8.89 Khafajah: Pottery samples 2824-2828. Tell Asmar: Pottery sample 2829. Abu Qasim: Pottery samples 2830-2832. Kheit Qasim: Pottery samples 2833-2834. Halawa: Pottery sample 2839

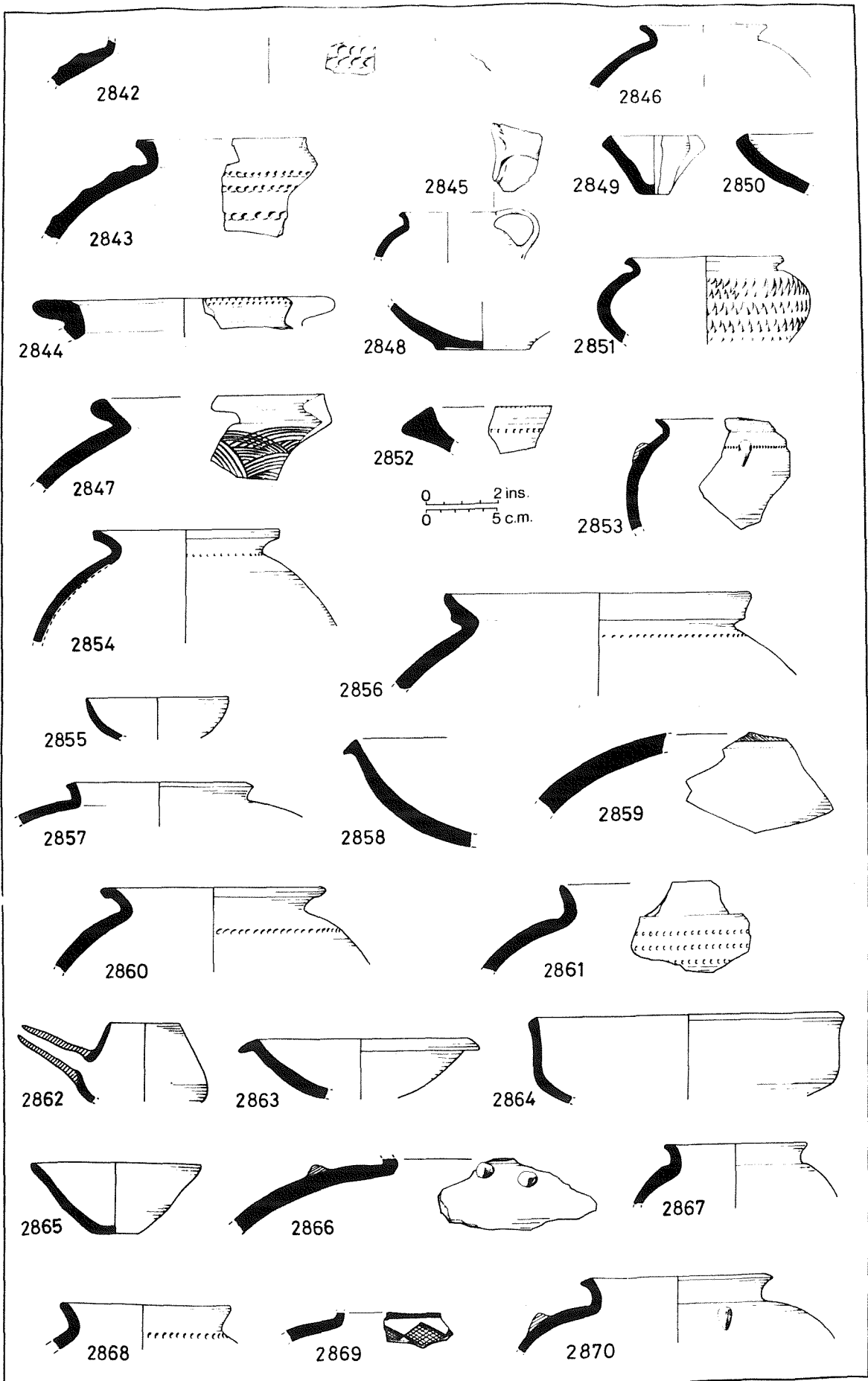

Fig. 8.90 Tell al Rubeidheh: Pottery samples 2848-2870 (¼)

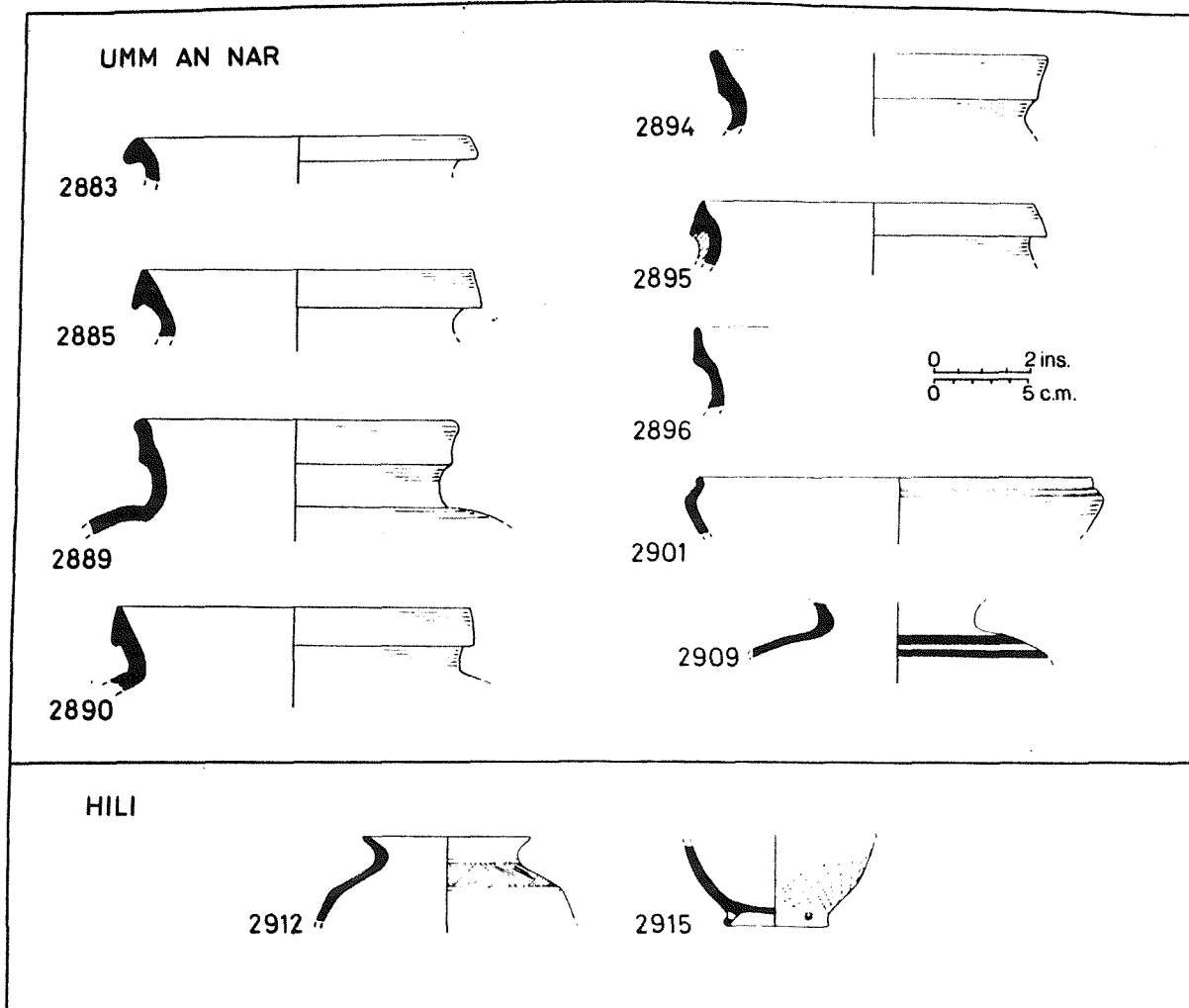

Fig. 8.91 Umm an Nar: Pottery samples 2883-2909 (¼)
Hili: Pottery samples 2912-2915 (¼)