





A comprehensive search for high-velocity X-ray sources: new compact object binary candidates in the *Gaia* era

Yue Zhao ^{1,★}, Poshak Gandhi ¹, Christian Knigge ¹, Phil Charles^{1,2,3}, Daniel Stern,⁴ Peter Boorman,^{5,6} Pornisara Nuchvanichakul ¹, Cordelia Dashwood Brown¹ and David A.H. Buckley ^{7,8}

¹*School of Physics & Astronomy, University of Southampton, Highfield, Southampton SO17 1BJ, UK*

²*Astrophysics, Department of Physics, University of Oxford, Keble Road, Oxford OX1 3RH, UK*

³*Department of Physics, University of the Free State, PO Box 339, Bloemfontein 9300, South Africa*

⁴*Jet Propulsion Laboratory, California Institute of Technology, Pasadena, CA 91109, USA*

⁵*Max-Planck-Institut für Extraterrestrische Physik, Gießenbachstraße 1, D-85748 Garching, Germany*

⁶*Cahill Center for Astrophysics, California Institute of Technology, 1216 East California Boulevard, Pasadena, CA 91125, USA*

⁷*South African Astronomical Observatory, PO Box 9, Observatory 7935, South Africa*

⁸*Department of Astronomy, University of Cape Town, Private Bag X3, Rondebosch 7701, South Africa*

Accepted 2026 January 7. Received 2025 December 30; in original form 2025 August 11

ABSTRACT

We perform a comprehensive search for high-velocity X-ray sources with large X-ray/optical flux ratios (F_X/F_G), identifying candidates for interacting black hole or neutron star binaries potentially accelerated by supernova natal kicks. We cross-match X-ray point sources from a variety of catalogues (*Chandra*, *XMM-Newton*, *Swift*, and *eROSITA*) with *Gaia* DR3. Using *Gaia* coordinates, parallaxes, and proper motions, we compute peculiar velocities (v_{pec}) relative to Galactic disc rotation. Remaining agnostic about radial velocities (RVs), we vary RVs to find the minimum possible v_{pec} values ($v_{\text{pec,min}}$). Uncertainties on $v_{\text{pec,min}}$ are estimated via Monte Carlo resampling, and we select X-ray sources that have 1σ lower limits on $v_{\text{pec,min}} \geq 200 \text{ km s}^{-1}$ and high F_X/F_G values. We show that this velocity threshold excludes most contaminants (e.g. cataclysmic variables and active binaries) while retaining a sensible fraction of compact object binaries, demonstrating that v_{pec} could serve as an effective indicator for the presence of a neutron star or black hole companion. Our selection yields a sample of 2372 sources, from which we construct a gold sample of 7 sources that have relatively well-constrained astrometry and confident optical counterparts. Follow-up is necessary to confirm and characterise their high-energy emission, as well as a Galactic disc vs. halo origin.

Key words: binary: close – stars: black hole – stars: neutron – supernova: general – X-rays: binaries.

1 INTRODUCTION

Compact object binaries (COBs), systems in which a neutron star (NS) or a black hole (BH) orbits a non-degenerate companion, have yielded critical insights into compact objects and their associated physics. NSs, for instance, serve as natural laboratories for studying matter under extreme densities, offering a unique opportunity to probe the physics of ultra-dense matter (e.g. J. M. Lattimer 2012). Observations of emission from regions of extreme gravity near these compact objects enable tests of relativistic effects (e.g. B. Kleihaus, J. Kunz & E. Radu 2011; G. Dvali & C. Gomez 2013; S. B. Giddings 2014). X-rays in these systems are produced by interactions between the compact object and its non-degenerate companion. Their emission traces high-energy processes such as accretion onto the compact object in X-ray binaries (XRBs; e.g. J. Frank, A. King & D. Raine 1992) or interactions

between relativistic winds and the companion’s material in binary pulsars (BPSRs; e.g. S. V. Bogovalov et al. 2019). Moreover, BHs and NSs have likely all experienced supernovae, making COBs a valuable probe for studying supernova mechanisms and energetics (see e.g. H.-T. Janka 2012, for a review).

The non-degenerate companion in a COB, also referred to as the optically luminous component, plays an important role in observing and characterising the ‘dark’ compact objects. By tracking the orbital motion of the luminous component, studies have constrained their binary orbits, and, in some cases, the mass of the compact object can be determined dynamically – providing a definitive classification as either a BH or NS (e.g. T. A. Thompson et al. 2019; K. El-Badry et al. 2023). The luminous component also serves as a tracer of the binary’s systemic velocity, offering insights into the potential energetics of its birth supernova. It is broadly accepted that a supernova imparts an impetus to the BH or NS, referred to as a natal kick (NK), via ejection of baryonic matter (A. Blaauw 1961) and/or asymmetric emission of neu-

* E-mail: Yue.Zhao@soton.ac.uk

trinos (N. N. Chugai 1984; O. F. Dorofeev, V. N. Rodionov & I. M. Ternov 1985; P. Arras & D. Lai 1999). The binary’s kinematic properties therefore provide an observational connection to the underlying physics of NKs.

Despite an ever-growing sample, our understanding of compact object demographics remains significantly incomplete. This is mainly due to the dearth of confirmed examples. There are only ≈ 30 BHs that have been dynamically confirmed (J. M. Corral-Santana et al. 2016), but the consensus is that our galaxy contains $\sim 10^8$ BHs (e.g. A. Olejak et al. 2020); similarly for NSs, while over ≈ 3000 have been discovered as radio pulsars (R. N. Manchester et al. 2005), this only represents a small ($\sim 10^{-5}$) fraction of the predicted population (e.g. M. Gullón et al. 2014; M. Cieřlar, T. Bulik & S. Osłowski 2020; C.-A. Faucher-Giguère & V. M. Kaspi 2006). Discovery of more COBs provides an important channel of enriching our sample of NSs and BHs and is particularly useful in constraining the related binary evolution models.

Systematic searches for new COBs have gained significant momentum since the *ROSAT* All-Sky Survey (RASS; J. Truemper 1982; W. Voges et al. 1996, 1999, 2000; T. Boller et al. 2016). RASS surpassed previous surveys in both sensitivity and angular resolution (W. Voges et al. 2000), and RASS sources have been cross-matched against optical catalogues to search for new XRBs (e.g. C. Motch et al. 1997). Since the turn of the millennium, even fainter sources are detected by instruments with larger collecting areas, such as the *Chandra X-ray Observatory* (*Chandra*), the *XMM-Newton Telescope* (*XMM*), and the *Neil Gehrels Swift Observatory* (*Swift*); however, these searches have been focused on restricted regions given the small fields of view of these instruments (e.g. P. G. Jonker et al. 2011; A. Bahramian et al. 2021). Some of these sources have been identified by optical/near-IR follow-up or cross-referencing with existing catalogues (e.g. A. Nebot Gómez-Morán et al. 2013; A. W. Shaw et al. 2020). The *Gaia* mission (Gaia Collaboration 2016) has made it possible to identify optical counterparts to X-ray sources on large scales. In fact, searches just based on *Gaia* astrometry (e.g. S. Shahaf et al. 2023) and/or photometric data (e.g. R. Gomel et al. 2023) have already identified many new candidates. This includes some non-interacting COBs (NICOBs) that have been dynamically confirmed (e.g. K. El-Badry et al. 2023; Gaia Collaboration 2024), and more NICOBs will be revealed in future *Gaia* releases (e.g. C. Chawla, S. Chatterjee & K. Breivik 2025). Efforts have also been made combining non-single star information inferred from *Gaia* astrometric fits and archival X-ray catalogues for new XRB candidates (e.g. P. Gandhi et al. 2022). Eventually, the eROSITA all-sky survey (eRASS; P. Predehl et al. 2021; A. Merloni et al. 2024) will provide X-ray coverage of the full sky at unprecedented depths. The first data release has already revealed 930 203 sources over the western Galactic hemisphere at an X-ray (0.2 – 2.3 keV) depth of $\gtrsim 10^{-14}$ erg cm $^{-2}$ s $^{-1}$ (A. Merloni et al. 2024), and some new COB candidates have been discovered. For example, A. Zainab et al. (2024) have followed-up one of the resulting XRB candidates, finding optical spectral features typical of high-mass XRBs (HMXBs), thereby indicating the great potential of this survey for revealing new XRBs.

A major challenge of finding new XRB candidates from large X-ray surveys or catalogues is contamination by X-ray emission from other objects; major contaminating X-ray emitters include cataclysmic variables (CVs), active stars/active binaries, and young stellar objects (YSOs). These objects have overlapping features with XRBs, and sometimes can only be identified

via dedicated follow-up observations. A CV consists of a white dwarf accreting from a low-mass cool star, so they have accretion-induced X-rays as well as soft X-rays from the very hot white dwarf surface. X-ray luminosities are around 10^{29-31} erg s $^{-1}$ in quiescence (e.g. R. C. Reis et al. 2013), but this can reach $\sim 10^{33-34}$ erg s $^{-1}$ in outburst (D. S. Baskill, P. J. Wheatley & J. P. Osborne 2005). Non-thermal processes in stellar coronae can emit X-rays (see e.g. M. Güdel 2004, for a review) with luminosities ranging between $\approx 10^{27-31}$ erg s $^{-1}$ (e.g. S. Wang et al. 2020). Coronal activity can be greatly enhanced in active binaries where the stars are tidally locked and forced to rotate rapidly; for example, RS CVn systems (e.g. F. Walter, P. Charles & S. Bowyer 1978a, b) – close binaries composed of a subgiant or giant star and a main-sequence or subgiant companion – are strong X-ray sources as are close binaries of later-type dwarfs (e.g. BY Dra; R. C. Dempsey et al. 1997). X-ray emission has also been observed in subclasses of YSOs, typically in later-stage YSOs (e.g. T Tauri stars), which is attributed to enhanced coronal activity and accretion shocks (see e.g. E. D. Feigelson & T. Montmerle 1999, for a review).

Without dedicated spectroscopic or time-domain observations, one effective way to distinguish between stellar coronal X-ray emission and accretion onto compact objects is from the X-ray-to-bolometric ratio (L_X/L_{bol}). This ratio in active stars/binaries, especially those with late-type dwarfs, does not exceed the saturation limit of $\sim 10^{-3}$ (O. Vilhu & S. M. Rucinski 1983; O. Vilhu 1984; O. Vilhu & F. M. Walter 1987; T. A. Fleming, I. M. Gioia & T. Maccacaro 1989), which also holds for most RS CVn systems (e.g. F. M. Walter & S. Bowyer 1981). Moreover, YSOs have L_X/L_{bol} close to the saturation limit, between 10^{-4} and 10^{-3} (O. Vilhu 1984; O. Vilhu & F. M. Walter 1987; N. J. Wright et al. 2011). In accreting compact objects, X-ray emission accounts for a much higher proportion of the system’s energetics, and L_X/L_{bol} is generally above the saturation limit (e.g. F. Bernardini et al. 2016). This applies to both Galactic XRBs and to active galactic nuclei (AGNs). In actual applications, bolometric flux/luminosities is often substituted by more observable values in optical bands. For example, H. Tranin et al. (2022) present X-ray/*r*-band flux ratios for the common X-ray emitters, clearly separating stars from XRBs and CVs. A more recent and comprehensive study is presented by A. C. Rodriguez (2024, R24 hereafter), who uses the *Gaia* G-band flux (F_G) for the X-ray/optical ratios and developed an empirical relation between F_X/F_G and the *Gaia* Bp – Rp colour to separate active stars/binaries and YSOs from accreting compact objects (more details in Section 2.9). Y. Wang et al. (2025) apply a transformed version of this empirical relation (see their equation 6) to the Data Preview 1 release of the *Legacy Survey of Space and Time* (*LSST*) from the *Vera C. Rubin Observatory* to search for potential COBs. Future *LSST* releases will offer much broader and deeper coverage for such searches.

X-ray/optical ratios have proved effective in selecting accreting compact objects, but less so in BH or NS XRB searches due to the difficulty in distinguishing them from CVs. It is, however, possible to make use of the evolutionary difference between CVs and BH or NS binaries to further refine candidate samples. The key difference is that BHs and NSs have experienced energetic supernovae, while white dwarfs in CVs have not. NKs associated with the supernovae can greatly modify the kinematics of the compact object and/or the COB as a whole. In certain instances, the parent binary can survive the supernova and be greatly accelerated (N. Brandt & P. Podsiadlowski 1995; G. Nelemans, T. M. Tauris & E. P.

J. van den Heuvel 1999), and this imprint of NKs can be observed as high or even runaway space velocities. In fact, a number of studies have found high peculiar velocities (v_{pec}) in both isolated pulsars (e.g. A. G. Lyne & D. R. Lorimer 1994; G. Hobbs et al. 2005), and COBs, including XRBs (e.g. I. F. Mirabel et al. 2001; P. Atri et al. 2019; P. Gandhi et al. 2019; F. Fortin et al. 2022; T. N. O’Doherty et al. 2023; Y. Zhao et al. 2023; C. Dashwood Brown, P. Gandhi & Y. Zhao 2024) and BPSRs (e.g. R. J. Jennings et al. 2018; T. N. O’Doherty et al. 2023; Y. Zhao et al. 2023). v_{pec} is the space velocity relative to the bulk motion of the parent population, which has been broadly used as an observational proxy for NK strength.

In this work, we conduct a comprehensive search for high-velocity X-ray sources (HVXSSs) using archival X-ray source catalogues and astrometric information from the *Gaia* survey. By cross-matching X-ray catalogues with *Gaia*, a sample of HVXSSs that have high X-ray/optical ratios are selected. In Section 2, we introduce the X-ray source catalogues employed, cross-matching techniques, and the selection processes used to identify the HVXSS sample; we also further curate a sample of gold sources that have well-constrained astrometry and robust X-ray/*Gaia* association. In Section 3, we overview properties of the selected HVXSS sample. In Section 4, we compare the HVXSSs to a control sample and discuss individual gold sources. Finally, in Section 5, we summarize our findings and draw our main conclusions.

2 METHODOLOGY

2.1 X-ray catalogues

The following sections summarize the construction of the final sample, which integrates data from various up-to-date X-ray source catalogues, including the *Chandra* Source catalogue (CSC, ver. 2.1; I. N. Evans et al. 2024), the *XMM* Serendipitous Source catalogue (4XMM, ver. DR14; N. A. Webb et al. 2020), the *Swift*-XRT Point Source catalogue (2SXPS; P. A. Evans et al. 2020), and the eRASS source catalogue (ver. DE DR1; A. Merloni et al. 2024). This results in a raw total exceeding 2.1 million X-ray sources.

2.2 Selection of point sources

We select point sources that are confidently detected in each catalogue. For CSC, this corresponds to `significance` ≥ 5.0 , `extent_flag` = FALSE, and `conf_flag` = FALSE. For 4XMM DR14, we set a 5σ detection limit (`SC_DET_ML` ≥ 14 ; N. A. Webb et al. 2020), only keeping those with `SC_SUM_FLAG` = 0 and `CONFUSED` = ‘f’ to avoid spurious and confused sources; extended sources are excluded by constraining `SC_EXTENT` $\leq 1''$. To clean the 2SXPS catalogue, we specify `DetFlag` = 0 and `FieldFlag` = 0; this keeps confident point sources whose fields were not affected by stray light, diffuse emission, or artefacts. Finally, for the eRASS catalogue, we keep sources with `DET_LIKE` above 10, which reduces the spurious detection rate to ≈ 1 per cent (R. Seppi et al. 2022); Extended sources are excluded by specifying `EXT_LIKE` = 0. Without removing duplication, this results in a total of 980, 560 confident sources.

2.3 Calibrate X-ray positional uncertainties and removal of duplicated X-ray sources

All X-ray positional uncertainties from different catalogues are converted to a common scale corresponding to one Mahalanobis

radius—the circular radius enclosing 39.3 per cent of the probability in a 2D Gaussian positional error distribution. This calibrated error radius is denoted by $r_{\text{err},x}$.

For the CSC, the semi-major (`err_ellipse_r0`) and semi-minor (`err_ellipse_r1`) axes of the positional error ellipse represent 95 per cent confidence intervals.¹ We estimate a circular radius as the geometric mean of the two axes, $\sqrt{\text{err_ellipse_r0} \times \text{err_ellipse_r1}}$. Assume an isotropic 2D Gaussian, the cumulative probability distribution function is given by

$$P(< r) = 1 - e^{-r^2/2}, \quad (1)$$

where r is in units of Mahalanobis radii. Therefore, the conversion factor from radius enclosing 95 per cent probability is given by $1/\sqrt{-2 \ln(1 - 0.95)} = 0.4085$.

For the 4XMM, the positional error radius (`sc_poserr`) encloses the true position with 63 per cent probability,² corresponding to $\sqrt{2}$ Mahalanobis radii. We therefore apply a conversion factor of $1/\sqrt{2} = 0.7071$.

For the 2SXPS, the quoted error radius (`ERR90`) represents 90 per cent confidence under a Rayleigh distribution³, equivalent to 2.146 Mahalanobis radius, giving a conversion factor of 0.4660.

Finally, the eRASS positional error radii already correspond to one Mahalanobis radius⁴, so no conversion is required.

We then auto-correlate the 980, 560 source positions to identify and remove potential duplicates. Using the `KDTree` implementation in `SCIPY`, we efficiently search for pairs of sources whose positional error circles overlap, considering them as matches. Specifically, a pair of sources are considered identical, if their separation is smaller than the summed $r_{\text{err},x}$ values. All matching pairs are then grouped into connected components using a graph constructed with the `NetworkX` package (A. A. Hagberg, D. A. Schult & P. J. Swart 2008). Within each group, we retain the X-ray ID with the smallest $r_{\text{err},x}$. This step removes a total of 28,772 sources, leaving a total of 951, 788 sources.

2.4 Cross-match with *Gaia*

The deduplicated catalogue is then cross-matched against the *Gaia* DR3 catalogue (Gaia Collaboration 2023). A preliminary cross-match was performed using the `NWAY` package (M. Salvato et al. 2018), which is built on a Bayesian framework that provides match probabilities. We set the maximum matching radius to 15 arcsec, which is greater than 99 per cent of the positional uncertainties in all four catalogues. We do not limit our cross-matching with additional prior information, so our subsequent selection processes can be based on a comprehensive sample. We then only kept the matches that have `p_any` ≥ 0.9 , `p_single` ≥ 0.9 , and `match_flag` = 1. `p_any` is the probability that an X-ray source has any *Gaia* counterpart, `p_single` is the probability that compares this *Gaia* association vs. no association (T. Budavári & A. S. Szalay 2008). We also `match_flag` = 1, which keeps only the most confident *Gaia* counterpart for each X-ray source. After this step, we obtained a total of 591, 223 confident matches.

After the above steps, we found a total of 18, 516 *unique Gaia* sources that are matched to multiple *distinct* X-ray sources (Sec-

¹<https://cxc.cfa.harvard.edu/csc/columns/positions.html>

²<http://xmmssc.irap.omp.eu/Catalogue/4XMM-DR14/Coordinates.html>

³<https://www.swift.ac.uk/LSXPS/docs.php>

⁴<https://erosita.mpe.mpg.de/dr1>

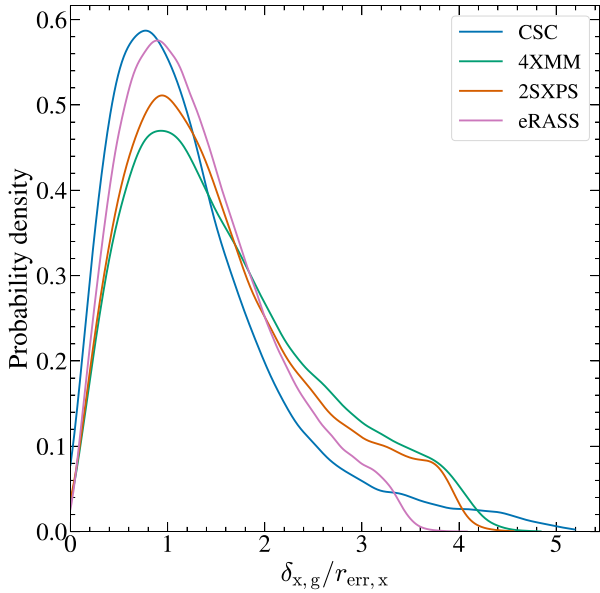

Figure 1. Distributions of *Gaia*/X-ray source separation (in units of positional uncertainty, i.e. $\delta_{x,g}/r_{\text{err},x}$) for unique one-to-one NWAY matches (by X-ray source catalogues) following the cleaning process in Section 2.4. The probability density is estimated by a Gaussian kernel.

tion 2.3). In fact, some high-probability NWAY *Gaia* counterparts lie beyond $r_{\text{err},x}$ from the X-ray positions, making one-to-many *Gaia*/X-ray matches possible even after the deduplication in Section 2.3 and the above probability cuts. We retain only the closest pairs in terms of $\delta_{x,g}/r_{\text{err},x}$, removing a total of 19,305 matches. The cleaned *Gaia*/X-ray cross-matched catalogue contains 571 918 one-to-one matches. Fig. 1 shows the distribution of their *Gaia*/X-ray angular separations ($\delta_{x,g}$) in units of $r_{\text{err},x}$.

Two additional steps are applied to retain only the most robust matches: (1) X-ray sources with $r_{\text{err},x} \geq 10$ arcsec are removed, and (2) only X-ray sources whose *Gaia* counterpart is the sole match within $2r_{\text{err},x}$ are kept. This keeps 364,507 sources.

2.5 Producing a kinematics-worthy sample

With *Gaia* IDs, we further clean the sample by keeping sources that have at least these astrometric parameters: coordinates (α, δ), parallax (ϖ), and two proper motion (PM) components ($\mu_\alpha \cos \delta, \mu_\delta$). These are needed for deriving their kinematic properties. Note that radial velocity (RV) is not necessary in our selection, as we will compute their space velocities in a RV-agnostic way (Section 2.7). We use the *Gaia* `astrometric_params_solved` flag—a 7-bit indicator of which astrometric parameters were estimated—to select sources with valid astrometric solutions, retaining only those with `astrometric_params_solved = 31, 63, or 95`.

We also removed quasi-stellar objects (QSOs) and galaxy candidates identified by the *Gaia* Discrete Source Classifier (DSC; L. Delchambre et al. 2023). The DSC provides combined class probabilities based on *Gaia* astrometry, photometry, and BP/RP spectra; for example, `classprob_dsc_combmod_quasar` gives the combined probability that a source is a QSO. We keep sources with an overall combined (‘Combmod’) probability of being a star (`classprob_dsc_combmod_star`) greater than 0.9, as well as those not classified by the DSC (i.e. with no

`classprob_dsc_combmod_star` available). This step produces a sample of 131,960 *Gaia* sources.

2.6 Distances

We use the inferred distances from the (C. A. L. Bailer-Jones et al. 2021, hereafter B21) catalogue, prioritising the values inferred by incorporating *Gaia* parallaxes and photometry, which are called ‘photogeometric’ distances (d_{b21}). This estimate gives generally more constrained distributions compared to those of the purely geometrically-inferred values (B21).

The *Gaia* archive only provides point estimates (medians) and credible interval bounds, and in many cases, the upper and lower errors are asymmetric, indicating a skewed posterior. For our Monte Carlo simulation, we employ the gamma distribution to approximate the posterior, whose density distribution function is given by

$$f(d) = \frac{1}{\Gamma(\alpha)\theta^\alpha} d^{\alpha-1} \exp\left(-\frac{d}{\theta}\right). \quad (2)$$

Here, α and θ determine the shape of the distribution, and we adjust their values to fit the lower and upper bounds, while freezing the mode of the distribution to the reported median. The best fit is found by minimizing summed quadratic difference between nominal and analytical values of the bounds.

2.7 Minimum peculiar velocity

We then compute v_{pec} for the kinematics-worthy sample. In the context of this work, we assume that these sources were born in the Galactic disc, so by definition, v_{pec} is the 3D space velocity relative to disc rotation at the source’s projected radial offset from the Galactic centre. Computation is set up using the rotation curve defined under the `MWPotential2014` from the `GALPY` package (J. Bovy 2015), adopting $R_0 = 8.34 \pm 0.16$ kpc, the rotation speed of the local standard of rest (LSR) $\Theta_0 = 240 \pm 8$ km s⁻¹, and the Cartesian components of solar motion relative to the LSR, $(U_\odot, V_\odot, W_\odot) = (10.7 \pm 1.8, 15.6 \pm 6.8, 8.9 \pm 0.9)$ km s⁻¹ (M. J. Reid et al. 2014).

We then followed the formulation in M. J. Reid et al. (2009) to convert the astrometric parameters to v_{pec} . For most of our sources, there is no RV information; even though *Gaia* provides RVs for some (generally bright) sources, they do not necessarily track systemic motion of the source (in cases where the sources are not single). For non-single sources, it is the systemic RV (γ) that is needed for calculating v_{pec} . However, measuring γ usually requires multi-epoch RV values, which is challenging to obtain on a large scale. We instead stayed agnostic to the exact γ but assumed a broad range of values and searched for the minimum possible v_{pec} value, denoted as the minimum peculiar velocity ($v_{\text{pec},\text{min}}$), and the corresponding γ value is denoted as γ_{min} . Uncertainties on $v_{\text{pec},\text{min}}$ were propagated from all input astrometric parameters and Galactic constants following a Monte Carlo resampling method. Specifically, we drew 1000 samples assuming a normal distribution centred on the nominal values and spread as their 1σ uncertainties for the proper motion components, while sampling from the approximated posterior (Section 2.6). Then, from the resulting $v_{\text{pec},\text{min}}$ values, we found the 16th and 84th percentiles as the ($\approx 1\sigma$) lower and upper limits. In Fig. 2, we show an example of v_{pec} as a convex function of γ , and the location of $v_{\text{pec},\text{min}}$ and its 1σ lower limit ($v_{\text{pec},\text{min},\text{lo}}$).

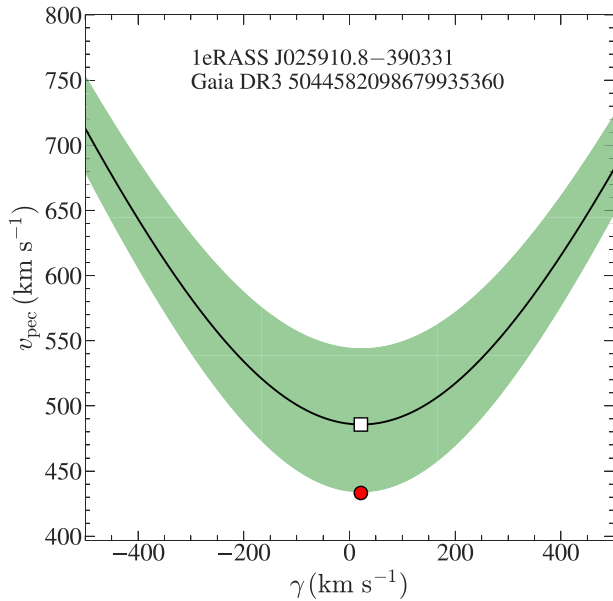

Figure 2. Peculiar velocity (v_{pec}) values at a range of systemic radial velocities (γ) for the X-ray source 1eRASS J025910.8–390331. The shaded area represents the 1σ confidence region. The minimum v_{pec} ($v_{\text{pec,min}}$) and the 1σ lower limit of $v_{\text{pec,min}}$ ($v_{\text{pec,min,lo}}$) are marked by a open square and a filled red circle, respectively.

2.8 Where to draw the line?

COBs are generally expected to be accelerated by NKs and move at faster v_{pec} compared to objects that have never experienced supernovae, but how distinct are they compared to the major contaminants? To make a comparison, we use the *Gaia* astrometry of known COBs compiled in Y. Zhao et al. (2023), including XRBs, BPSRs, and NICOBs; we also expanded this compilation by adding new NICOBs discovered by K. El-Badry et al. (2024). We then collate major contaminating sources from different references, including active stars (N. J. Wright et al. 2011), active binaries (Z. Eker et al. 2008), confident YSO candidates (G. Marton et al. 2019), and CVs (H. Ritter & U. Kolb 2003). Similar to our selection process above (Section 2.5), these catalogues are also checked against *Gaia* DR3, keeping those that have at least 5-parameter astrometry. To then compute their v_{pec} values, we use *Gaia* radial velocities for active stars and YSOs, systemic radial velocities compiled by T. Ak et al. (2015) for CVs (see also R. Canbay et al. 2025), and the centre-of-mass radial velocities from the Z. Eker et al. (2008) catalogue for active binaries.

Fig. 3 compares the empirical cumulative distribution functions of v_{pec} for COBs (XRBs, BPSRs, and NICOBs) with those for different classes of contaminating sources. While HMXBs and some NICOBs are somewhat similar to the contaminating sources, most low-mass XRBs (LMXBs) and BPSRs move at apparently higher velocities (i.e. above $\approx 100 \text{ km s}^{-1}$). We chose 200 km s^{-1} as the limit for selecting HVXSs in this study. This limit effectively excludes over 97 per cent contaminating sources of all kinds, while maintaining sensible fractions of LMXBs (≈ 15 per cent), BPSRs (≈ 5 per cent), and NICOBs (≈ 10 per cent) (Fig. 3).

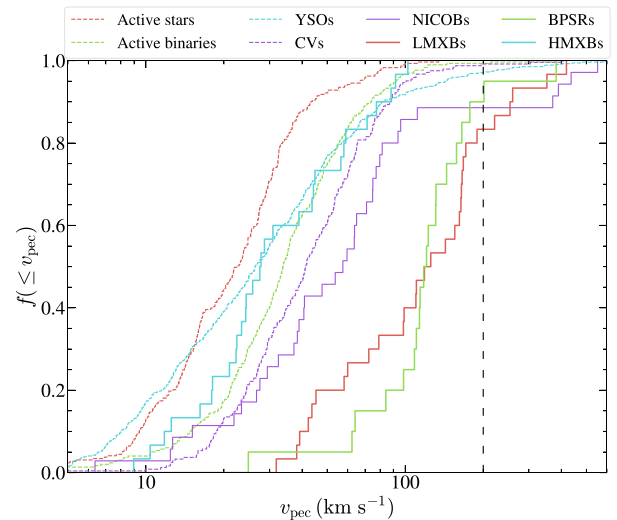

Figure 3. Empirical cumulative distribution functions of peculiar velocity (v_{pec}) plotted for types of compact object binaries, including low-mass X-ray binaries (LMXBs), high-mass X-ray binaries (HMXBs), binary pulsars (BPSRs), and non-interacting compact object binaries (NICOBs). Major contaminating sources to XRB searches are represented by dashed lines, including cataclysmic variables (CVs), active stars/binaries, and young stellar objects (YSOs). The vertical dashed line marks the lower limit of 200 km s^{-1} we used for selecting high-velocity sources. LMXBs and BPSRs have apparently higher v_{pec} values compared to the major contaminants.

2.9 The HVXS sample

For a more conservative selection of HVXSs, we use the 1σ lower limit on $v_{\text{pec,min}}$ ($v_{\text{pec,min,lo}}$), selecting sources with $v_{\text{pec,min,lo}} \geq 200 \text{ km s}^{-1}$ and keep sources that have a 1σ lower limit of X-ray/*Gaia* *G*-band flux ratios (F_X/F_G) above the empirical separatrix in R24. This gave a sample of 2867 sources. Additional cleaning was performed on this sample in order to obtain higher-confidence COB candidates.

(i) The first step is to remove known COBs (either identified as XRBs or BPSRs) and non-COBs (e.g. AGNs, CVs, YSOs, CVs, etc.). To do this, we cross-matched the sample against the SIMBAD data base with a search radius of 10 arcsec. This yielded a total of 396 matches. Extragalactic contaminants and their candidates (e.g. Galaxy, QSO, AGN, etc.) account for ≈ 37 per cent of this sample, while Galactic ones (e.g. YSO, CataclyV*, BYDraV, RSCVnV*, etc.) account for ≈ 10 per cent. The crossmatch reveals a minor fraction (≈ 7 per cent) of known COBs and their candidates, consistent with their general rarity. Stars (Star), the most common classifications (≈ 12 per cent), were kept. In addition, some classification – such as generic X-ray sources (X ≈ 8 per cent), and high-proper-motion stars (HighPM*; makes ≈ 2 per cent) – are also retained, as they directly align with our selection of HVXSs. The rest of the matches fall into ambiguous types that could plausibly host NSs or BHs. These are kept in our sample and summarized in Table A1. After this step, we are left with 2625 sources.

(ii) Our method of computing v_{pec} assumes a Galactic disc origin, which does not apply to sources associated with the halo. While it is challenging to systematically remove halo sources, some of the sources have been astrometrically identified as cluster members. To eliminate cluster members, we perform a pre-

Table 1. Combinations of criteria and their quality flags (Section 2.10).

	$\delta_{x,g} \leq r_{\text{err},x}$	$\varpi / \sigma_{\varpi} \geq 5$	$\frac{ d_{\text{inv}} - d_{\text{b21}} }{d_{\text{b21}}} \leq 0.2$	<i>N</i>
000 ₂ = 0				1450
001 ₂ = 1			✓	73
010 ₂ = 2		✓		6
011 ₂ = 3		✓	✓	20
100 ₂ = 4	✓			778
101 ₂ = 5	✓		✓	30
110 ₂ = 6	✓	✓		5
111 ₂ = 7	✓	✓	✓	10

liminary filtering by removing sources with indicative SIMBAD types and names (e.g. *Cl*, *ClG*, etc.). We further compared the sample *Gaia* *source_id* with those of likely open/globular cluster members in the E. L. Hunt & S. Reffert (2023) catalogue. This removes 2 likely cluster members from our sample, leaving us with 2623 sources.

(iii) We also removed likely members of the Small and the Large Magellanic Cloud (SMC and LMC). To do so, we cross-matched HVXS *Gaia* *source_ids* with the SMC and LMC membership catalogues from Ó. Jiménez-Arranz et al. (2023a, b). These studies provide membership probabilities for sources near the galaxies, and the distributions shows a clear bimodal pattern: one peak near 1 (high-confidence members) and another near zero (non-members). To ensure a conservative selection, we adopted a low probability threshold (0.01 for SMC and 0.002 for LMC) to remove likely members, effectively including most of the non-member peak near zero. This step gives a catalogue of 2584 sources.

(iv) In a final step, we remove astrometric solutions that are likely spurious using the fidelity parameter derived by J. Rybizki et al. (2022). This is derived from a neural network classifier trained on a broad set of *Gaia* parameters, and it takes a value between 0 and 1 to quantify the probability that a *Gaia* astrometric solution is good. Following their recommendation for optimal completeness, we use the updated parameter (*fidelity_v2*) and chose 0.5 as the threshold (see fig. a17 of J. Rybizki et al. 2022). This step reduces the sample size to 2372.

These selection steps toward the final HVXS sample are summarized in a flowchart in Fig. 4.

2.10 HVXS quality flags

We develop a 3-digit bitmask to encode the combinations of quality criteria (*quality*) satisfied by each HVXS. The design of these criteria is motivated by minimising confusion in positional matches, while ensuring a confident distance estimate which $v_{\text{pec},\text{min}}$ is strongly dependent on. From the most (leftmost) to the least significant (rightmost) bit, the corresponding conditions are

- (i) $\delta_{x,g} \leq r_{\text{err},x}$: *Gaia* counterpart within the 1σ X-ray error circle
- (ii) $\varpi / \sigma_{\varpi} \geq 5$: ϖ uncertainty less than 20 per cent
- (iii) $|d_{\text{inv}} - d_{\text{b21}}| / d_{\text{b21}} \leq 0.2$: d_{b21} within 20 per cent of d_{inv}

where $d_{\text{inv}} = 1/\varpi$ is the distance estimate by simply inverting the zeropoint-corrected ϖ . Note that meeting the second criterion will automatically exclude sources with negative ϖ values. The third criterion alone is not a strong quality flag but is a

necessary check when ϖ is relatively well-constrained (i.e. when the second and third conditions are both met). Combinations of criteria and their quality flags are listed in Table 1.

2.11 The control sample

We build a control sample to explore the effect of $v_{\text{pec},\text{min}}$ and F_x/F_G selection. We start from the kinematic-worthy sample (Section 2.5) and follow the same cleaning steps as for the construction of the HVXS sample (Section 2.9). After cleaning, we remove the HVXSs to obtain the control sample with a total of 94, 170 sources.

2.12 A gold sample

We build a gold sample from the HVXSs with quality flag of 7 (i.e. all three criteria in Section 2.10 are met), which gives a total of 10 sources. The gold sources all have robust NWAY matching probability *p_single* and *p_any* above 99 per cent, given the *Gaia* source density. We then performed a further curation of this sample, scrutinising the field around each individual source using available images from Pan-STARRS DR1 (K. C. Chambers et al. 2016), the DESI Legacy Imaging Survey (A. Dey et al. 2019), the DECam Plane Survey (DECaPS; E. F. Schlafly et al. 2018), the SkyMapper Southern Survey (C. A. Onken et al. 2024), and the *Galaxy Evolution Explorer* (GALEX; D. C. Martin et al. 2005). This step is to further remove ambiguous matches, especially in very crowded regions where faint interlopers are within $r_{\text{err},x}$ but not in *Gaia*.

After the above checks, we focus on a final total of 7 sources for further discussion in this work. However, since the exclusion process is mostly based on the matching confidence, it does not negate the potential physical significance of the remaining sources. Notably, the gold sample contains only eRASS sources after the curation, with a median $r_{\text{err},x}$ of a 4 arcsec. X-ray observations with precision localisation (e.g. *Chandra*/ACIS) would significantly reduce confusion.

2.13 Likely non-single sources

Gaia provides the *astrometric_excess_noise* (ϵ), an astrometric indicator of source non-singularity. This measures ‘astrometric wobble’, which is quantified by the deviation from a standard astrometric (5-parameter) fit. A ‘well-behaved’ source would have ϵ around zero, while a large positive ϵ indicates that the fit residuals deviate from the expected observational noise. Typically, ϵ is considered significant when its *astrometric_excess_noise_sig* (σ_{ϵ}) is greater than 2 (Gaia Collabo-

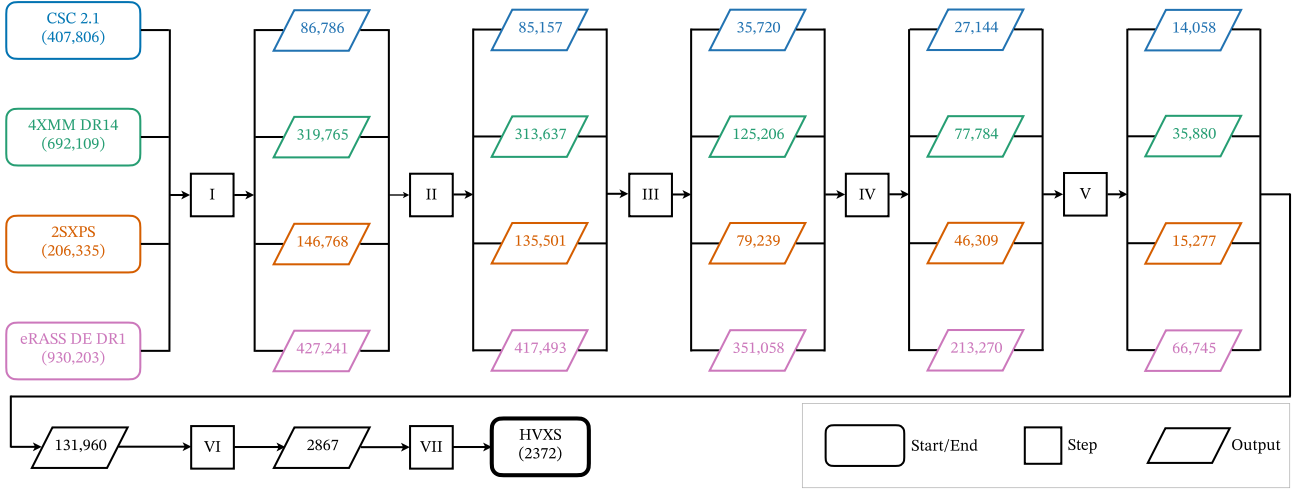

Figure 4. A flowchart demonstrating steps (represented by squares) toward the establishment of the final HVXS sample. Numbers of sources before and after each step are shown within the shapes. I: keep only confident point sources (Section 2.2); II: deduplication of X-ray catalogues (Section 2.3); III: cross-match with *Gaia* using *NWAY*, keeping only the high-probability and confident matches (Section 2.4); IV: keep only the closest *Gaia*/X-ray matches (Sect 2.4); further cleaning of the cross-matched catalogue, keeping X-ray sources whose (1) $r_{\text{err},x} \leq 10$ arcsec, (2) *Gaia* counterpart is within $2 r_{\text{err},x}$, and (3) *Gaia* counterpart is the only *Gaia* source within $2 r_{\text{err},x}$; V: keep sources that have at least 5 astrometric parameters, removing likely QSOs and galaxies (Section 2.5); VI: select based on $v_{\text{pec},\text{min},\text{lo}} \geq 200 \text{ km s}^{-1}$ and F_X/F_G above the R24 empirical separatrix (Section 2.9); VII: further cleaning (Section 2.9).

Table 2. A summary of samples.

Sample	# of sources	Description	Section
HVXS	2372	$v_{\text{pec},\text{min},\text{lo}} \geq 200 \text{ km s}^{-1}$ and F_X/F_G above the R24 empirical limit.	2.9
Control	94 170	Control sample chosen as a complement to the HVXS sample	2.11
Gold	7	Curated sources from HVXS with $\text{quality} = 7$	2.12

Table 3. Summary of the 7 curated gold sources (Section 2.12).

X-ray ID	<i>Gaia</i> DR3	$\delta_{x,g}$	<i>Gaia</i> G	F_X	Sig	d_{b21}	$v_{\text{pec},\text{min}}$	γ_{min}
(1)	(2)	($r_{\text{err},x}$) (3)	(4)	($10^{-14} \text{ erg cm}^{-2} \text{ s}^{-1}$) (5)	(6)	(kpc) (7)	(km s^{-1}) (8)	(km s^{-1}) (9)
1eRASS J003051.3–370912	5 003 862 819 415 658 112	0.8	16.96	6.9 ± 2.9	11.1	$3.0^{+0.5}_{-0.4}$	$394.8^{+64.6}_{-65.1}$	$7.1^{+0.3}_{-0.3}$
1eRASS J015648.6–224326	5 134 745 277 676 212 608	0.7	18.31	6.8 ± 2.2	24.8	$0.9^{+0.2}_{-0.2}$	$517.7^{+156.0}_{-138.1}$	$13.4^{+0.2}_{-0.2}$
1eRASS J025910.8–390331	5 044 582 098 679 935 360	0.5	15.79	3.0 ± 1.3	10.7	$1.7^{+0.1}_{-0.1}$	$487.4^{+51.7}_{-51.0}$	$22.0^{+0.6}_{-0.6}$
1eRASS J043509.3–481751	4 788 212 717 642 740 480	0.2	17.30	4.0 ± 1.0	29.1	$3.3^{+0.5}_{-0.5}$	$292.3^{+42.7}_{-32.9}$	$38.8^{+3.5}_{-2.7}$
1eRASS J082815.9+383457	911 214 901 400 669 824	0.5	16.63	8.5 ± 3.6	11.0	$0.60^{+0.02}_{-0.02}$	$238.9^{+45.9}_{-38.7}$	$5.1^{+0.1}_{-0.1}$
1eRASS J142449.5–153938	6 298 627 607 542 697 088	0.9	15.81	3.6 ± 1.5	10.8	$1.2^{+0.1}_{-0.1}$	$330.7^{+48.9}_{-45.7}$	$-16.9^{+1.3}_{-1.4}$
1eRASS J152027.0–030609	4 414 038 018 672 780 416	0.5	15.41	7.4 ± 2.8	12.8	$3.8^{+0.4}_{-0.4}$	$225.4^{+30.9}_{-23.9}$	$-16.0^{+0.4}_{-0.4}$

Note. (1) X-ray IAU name. (2) *Gaia* DR3 ID. (3) X-ray-*Gaia* angular separation in units of X-ray error radii. (4) *Gaia* G-band magnitude. (5) X-ray fluxes between 0.2 – 2.3 keV. (6) The 0.2 – 2.3 keV detection likelihood (det_like_0) of eRASS. (7) Photogeometric distance estimates from B21. (8) Minimum peculiar velocity. (9) The systemic radial velocity that minimises v_{pec} .

ration 2023). This deviation could be the result of binary orbital motion, so could be used as one measure of source binarity.

In our HVXS sample, about 54 per cent have positive ϵ , and ≈ 20 per cent of these positive ϵ values are significant ($\sigma_\epsilon \geq 2$). ϵ can be treated as a measure of astrometric wobble and therefore an estimate of the semi-major axis of binaries. P. Gandhi et al. (2022) used $\sqrt{2}\epsilon d$ as an estimate of semi-major axes assuming that the wobble is due to orbital motion. This estimate could be

very different from actual values for some binaries and should only be interpreted with caution.

3 RESULTS

Table 2 collates information of different samples, and key properties of the gold sources (Section 2.12) are listed in Table 3. Sky positions of the HVXS and gold samples are presented in a

Galactic map in Fig. 5, where the number density of the control sample is binned and displayed in the background. The western Galactic hemisphere is clearly more abundant in HVXs because of eRASS-DE DR1’s comprehensive coverage.

Fig. 6 displays the distribution of d_{b21} and $v_{\text{pec,min,lo}}$. The control sample exhibits a large peak around 0.4 kpc and a broad hump from 2-6 kpc. Overall, there is an upward trend of $v_{\text{pec,min,lo}}$ as a function of d_{b21} , so our selection on $v_{\text{pec,min,lo}}$ greatly reduces nearby (≤ 1 kpc) sources. The right panel shows distribution against ϵ , and HVXs spread across different regions of ϵ values, i.e. even relatively wide binary candidates can have large space velocities. Wide binaries are especially intriguing if they are moving at high space velocities, as their progenitors could be more prone to disruption by strong NKs.

Fig. 7 gives a photometric overview of the samples, showing a *Gaia* Bp – Rp colour–magnitude diagram (CMD) of the control, the HVXS, and the gold samples. Bp – Rp colours and absolute G-band magnitude (G) are only partly corrected for extinction for sources with available reddening and extinction estimates from *Gaia*’s General Stellar Parametrizer from Photometry module (GSP-Phot; R. Andrae et al. 2023). Overall, most HVXs are consistent with the control sample, but the latter has a broader distribution of colours. The HVXS has Bp – Rp colours between 0.6 and 2.2 (95 per cent equal-tail interval), corresponding to spectral types between F6V and M2V (M. J. Pecaut & E. E. Mamajek 2013), while the control sample hosts apparently more redder M dwarfs and giants. We also note that there is a slight blue excess of the HVXs relative to the control sample around G between 4 and 5, which is in line with our F_X/F_G selection of sources with prominent X-ray emission.

An overview of our samples’ $v_{\text{pec,min}}$ and F_X/F_G values are presented in Fig. 8. The solid line in each panel depicts the empirical relation from R24. Note that the X-ray bands are heterogeneous among different catalogues; the bands are relatively broader and similar for CSC (0.5-7.0 keV), *XMM* (0.2-12.0 keV), and 2SXPS (0.3-10.0 keV), while we use the more sensitive soft (0.2-2.3 keV) band for eRASS, so the F_X/F_G of eRASS sources should be treated as lower limits when compared to the other sources.

Fig. 9 presents optical finding charts for the 7 gold sample sources. These figures are referred to in the discussion of individual gold sources.

4 DISCUSSION

4.1 Individual gold sources

Here, we present a discussion of individual sources in the gold sample (Section 2.12). For each source, we focus on the robustness of the match to its *Gaia* counterpart, the value of $v_{\text{pec,min}}$, photometry, and possible binarity (Section 2.13). Throughout the discussion, all reported ϖ values have been corrected for zero-point offsets. Sources are referred to using the ‘RA’ part of their X-ray identifier (e.g. 1eRASS J003051.3–370912 is referred to as J003051.3).

1eRASS J003051.3–370912’s *Gaia* counterpart is a bright, blue source. There is a hint of a very faint source extended from the northeast of the counterpart, but it is not detected in *Gaia*. The photogeometric d_{b21} agrees well with d_{inv} , at approximately

3.0 kpc, placing the source slightly bluer than the main sequence⁵ in the CMD. The ϵ is non-zero (0.1 mas), but not significant enough to suggest non-singularity. The well-constrained d_{b21} and PM yield a relatively robust, high $v_{\text{pec,min,lo}}$ exceeding 300 km s^{-1} . Combined with the high F_X/F_G ratio, this suggests a very peculiar X-ray emitting system. It is currently ≈ 1.3 kpc from the Galactic plane so could be a halo source.

1eRASS J015648.6–224326’s X-ray error circle marginally overlaps with its *Gaia* counterpart. The only other nearby optical source is a faint, blue object located about $2r_{\text{err,x}}$ north-east of the X-ray position, and a faint *GALEX* source is also positionally coincident with this source, the UV emission can partly contribute to its blue colour. However, associating it with the X-ray source would require more precise localisation (with an instrument such as *Chandra*/ACIS). For now, we consider the nearest source to be the true counterpart. The **B21** estimate places the counterpart at $d_{b21} \approx 0.9$ kpc, in good agreement with d_{inv} . The source still has a high $v_{\text{pec,min,lo}}$ of $\approx 380 \text{ km s}^{-1}$ even at this relatively close distance. Another feature that makes this counterpart particularly interesting is its significant ϵ value (1.3 mas), which could be translated to a semi-major axis of approximately 1 AU (Fig. 6). This estimate is wider than typical XRBs ($\lesssim 1$ au), but should be taken cautiously as it is sensitive to the assumption that the astrometric wobble is entirely due to orbital motion. If further observations confirm the orbital parameter, it would then be particularly interesting to explore how such wide binaries could have been accelerated and still survived being disrupted either by a strong natal kick or by dynamical processes.

1eRASS J025910.8–390331’s *Gaia* counterpart is bright (G = 15.8) and well-separated from other sources in the field. Both **B21**’s photogeometric and d_{inv} give a d_{b21} of ≈ 1.7 kpc, and this, together with the Bp – Rp colour, places it bluer than the upper main sequence (Fig. 7). Its apparent PM makes it the fastest-moving source (in terms of $v_{\text{pec,min,lo}}$) among the gold sample sources, with $v_{\text{pec,min,lo}} \approx 436 \text{ km s}^{-1}$, making it a strong candidate for a runaway object escaping the Galactic potential. The *Gaia* counterpart also shows a non-zero ϵ (0.14 mas) that is moderately significant.

1eRASS J043509.3–481751’s position matches with a bright and blue *Gaia* source. There is a hint of a very faint source to the south of this counterpart, but it should have minimal effect on the astrometric and photometric measurements. The counterpart is also a significant *GALEX* UV source, which further favours the match. d_{b21} and d_{inv} are consistent, giving a distance around 3.3 kpc, and the *Gaia* photometry of J043509.3 is similar to that of J015648.6 and J025910.8, exhibiting a mild blue excess relative to the main sequence. Kinematically, J043509.3 is not particularly fast compared to other gold sources; indeed, the $v_{\text{pec,min,lo}} \approx 259 \text{ km s}^{-1}$ is only slightly above the selection limit. It has a non-zero ϵ of 0.16 mas, but it is not significant at its distance.

1eRASS J082815.9+383457 is the closest among the 7 gold sources, with a **B21** inferred distance of only ≈ 600 pc, consistent with its d_{inv} (≈ 1.7 mas). The field around the X-ray position is also clear of other optical sources, making the *Gaia* counterpart a very confident match. Its Bp – Rp colour exhibits a clear blue excess relative to the main sequence, which is unlikely to be a chance coincidence. Our current sample of XRBs lacks such ‘nearby’ systems (see e.g. A. Avakyan et al. 2023; M. Neumann et al. 2023), and the discovery and confirmation of addi-

⁵Here, the main sequence refers to that defined by the control sample.

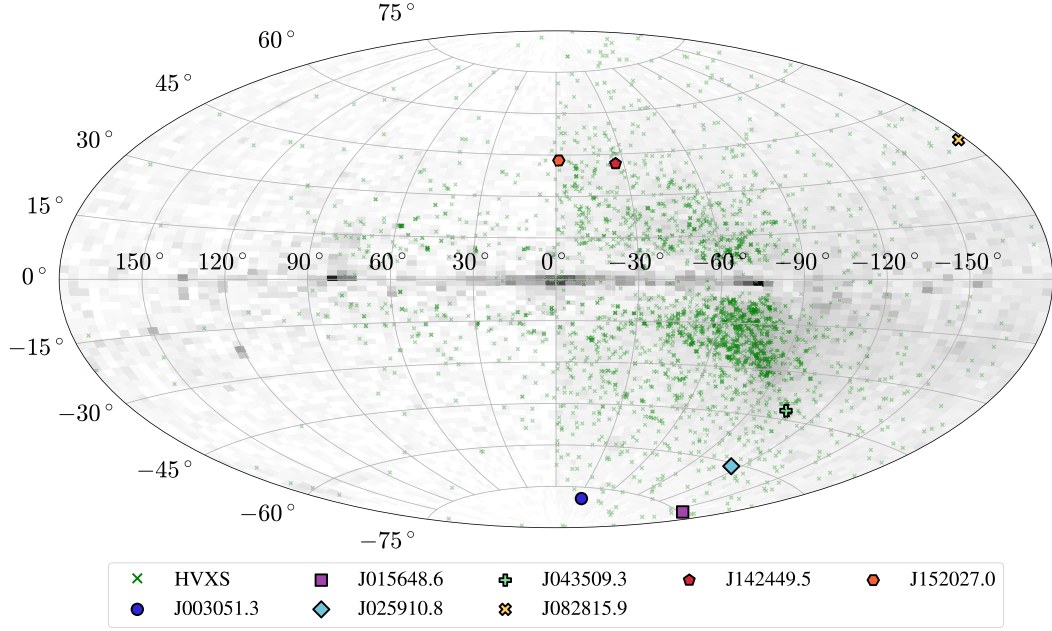

Figure 5. Galactic map showing the density distribution of the control sample (binned background in grey scale) and positions of the selected HVXs (crosses). The western Galactic hemisphere ($-180^\circ \leq l \leq 0^\circ$) is more abundant of HVXs due to the comprehensive coverage of the eRASS-DE DR1. Sources from the gold sample are indicated by markers of distinct shapes and colours.

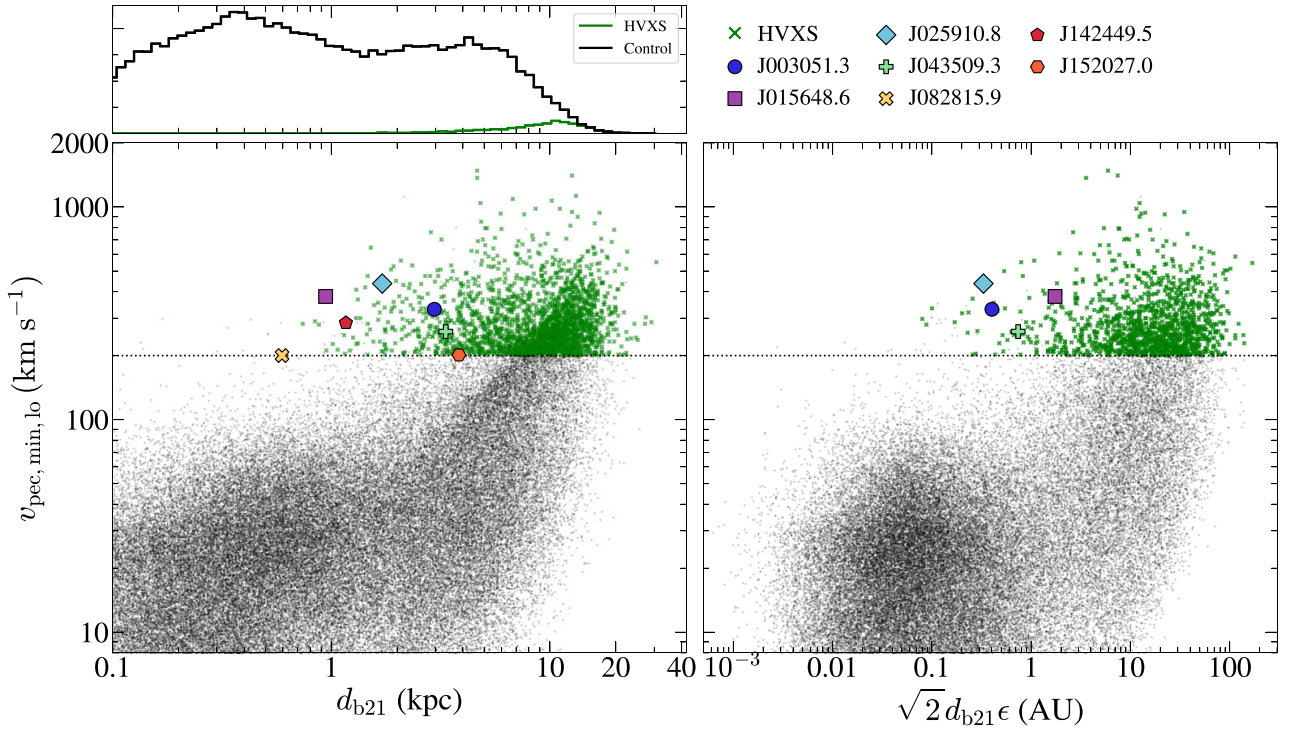

Figure 6. *Left:* Distribution of estimated distances (median values) and 1σ lower limits on $v_{\text{pec, min}}$ shown for the control sample (points) and the HVXS sample (crosses). The dotted horizontal line marks the 200 km s^{-1} limit on $v_{\text{pec, min, lo}}$ that we used to select the high-velocity sources; the top panel exhibits the d_{b21} distributions for the HVXS and control sample. *Right:* The same $v_{\text{pec, min}}$ lower limit plotted against estimates on binary semi-major axis for sources with non-zero astrometric excess noise (ϵ).

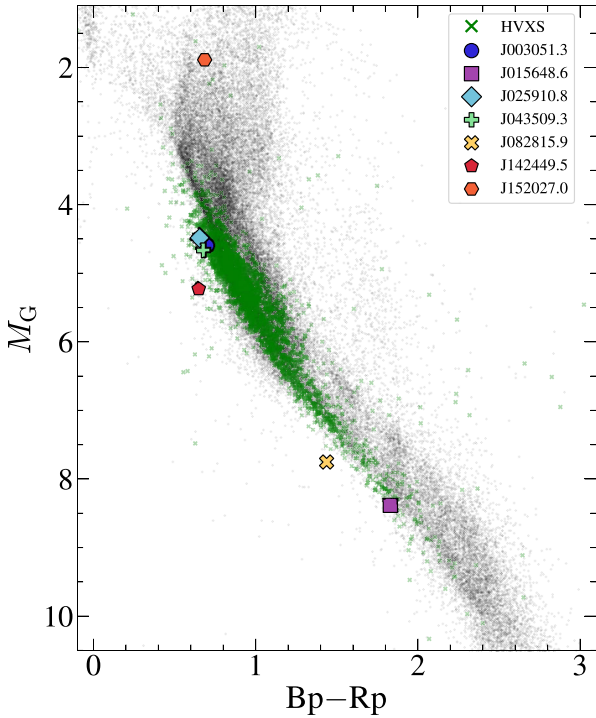

Figure 7. *Gaia* colour-magnitude diagram plotting $B_p - R_p$ colour versus G -band absolute magnitude (M_G) for the HVXS (crosses) and the control sample (points; Section 2.11). Sources from the gold sample are indicated by markers of distinct shapes and colours. Colours and magnitudes are corrected using available reddening and extinction values from GSP-Phot.

tional candidates would improve constraints on their local space density.

1eRASS J142449.5–153938’s *Gaia* counterpart lies approximately $0.9r_{\text{err},x}$ north-west of the X-ray position, and there is also a very faint source slightly to the east of the *Gaia* source, but it lies beyond $r_{\text{err},x}$. The *Gaia* counterpart positionally coincides with a *GALEX* UV source, so we consider it a genuine match to J142449.5. Both d_{b21} and d_{inv} give an estimated distance around 1.2 kpc, so its significant PM translates to a robust $v_{\text{pec},\text{min},\text{lo}} \approx 285 \text{ km s}^{-1}$. At this distance, the $B_p - R_p$ colour is in line with the UV emission, showing an apparent blue excess relative to the bulk of the HVXS sample.

1eRASS J152027.0–030609 is in a relatively uncrowded region, and its *Gaia* counterpart is the only source within its $r_{\text{err},x}$. The counterpart is also matched to a *GALEX* UV source, so we consider it a confident match to J152027.0. **B21** estimates a $d_{b21} \approx 3.8$ kpc, which is consistent with the d_{inv} (≈ 4.2 kpc). J152027.0 is located on the red side of the upper main sequence, apparently separated from other gold sample sources.

4.2 Uncertainties and limitations

There are uncertainties that we need to be aware of when interpreting the HVXSs regarding their possible nature as COBs, and even their conservatively selected high space velocities. We address these issues in this section.

4.2.1 Residual extragalactic contamination

The first aspect to consider is residual extragalactic contaminants. AGNs and galaxies were primarily removed using the *Gaia* DCS classification (Section 2.9), which achieves a relatively high completeness ($\gtrsim 90$ per cent; L. Delchambre et al. 2023), relying solely on *Gaia*’s (optical) astrometry, photometry and (less commonly) spectroscopy. AGNs are X-ray emitters that meet the high- F_x/F_G criterion, and the high-PM sources selected by the $v_{\text{pec},\text{min},\text{lo}}$ limit can also be mimicked by jet motion (e.g. Y. Shen et al. 2021; I. M. Khamitov et al. 2023). To give a quantitative sense of the contamination level, we refer to R. Seppi et al. (2022), who estimated ≈ 64 per cent of the eRASS sources are AGNs at its depth, while the DCS probability threshold (Section 2.5) removed ≈ 33 per cent of the sources in the eRASS catalogue. From another perspective, our crossmatch against SIMBAD suggests ≈ 37 per cent (out of 396 matches) of extragalactic contaminants, and this fraction translates to ≈ 878 contaminants amongst the HVXS sample. Therefore, some AGNs likely slip through our selection. Future follow-up observations will refine the classifications.

4.2.2 Uncertainty in source origin and kinematic interpretation

Another key caveat is the formulation of $v_{\text{pec},\text{min}}$. While subtracting rotation velocity effectively removes the contribution from bulk disc motion, it implicitly assumes a disc origin for all sources. Our cleaning procedure only excludes sources currently in clusters, while a more comprehensive kinematic determination of source origin would require constrained γ measurements, which are beyond the scope of this work. There are indications, however, that some HVXSs may not originate from the disc. First, they appear kinematically heated, exhibiting a broader distribution in vertical distance from the Galactic plane ($|z|$) than the control sample, with only ≈ 6 per cent of HVXSs within 1 kpc of the Galactic plane. Second, they have generally lower metallicities than the control sample. We examine this by using the *Gaia* GSP-Phot metallicity estimates ($[M/H]_{\text{gspphot}}$ ⁶). This is only available for a small (10 per cent) subset of HVXSs, but the distribution does peak around a sub-solar value of -1.1 , with just ≈ 6 per cent above -0.5 – the approximate median of $[M/H]_{\text{gspphot}}$ for known COBs (Section 2.8). We show the $[M/H]_{\text{gspphot}}$ distributions of the HVXS, control, and known COB samples in Fig. 10.

NKs are impulsive and energetic events, and when favourably oriented, they can propel disc-born COBs into the halo. This has been observed for some XRBs (e.g. J. I. González Hernández, R. Rebolo & G. Israelian 2008; D. A. Leahy & M. H. Abdallah 2014) and BPSRs (e.g. T. Shahbaz et al. 2022). For example, if a system orbiting at 238 km s^{-1} in the solar neighbourhood (i.e. in the disc and 8.34 kpc away from the Galactic centre) received an instantaneous acceleration that increases its vertical velocity component to 200 km s^{-1} , it can reach $|z|_{\text{max}} \approx 8$ kpc in ≈ 80 Myr (as computed by GALPY). The object can reach an even higher $|z|$ at a greater distance, where it experienced less deceleration in the z direction. However, NKs are not the only mechanism capable of producing such high velocities and large $|z|$. Some of these sources may instead be genuine halo objects that originated through other pathways. For example, halo stars and binaries can

⁶All $[M/H]_{\text{gspphot}}$ values have been calibrated using the `gdr3apcal` package: <https://github.com/mpi-astronomy/gdr3apcal>.

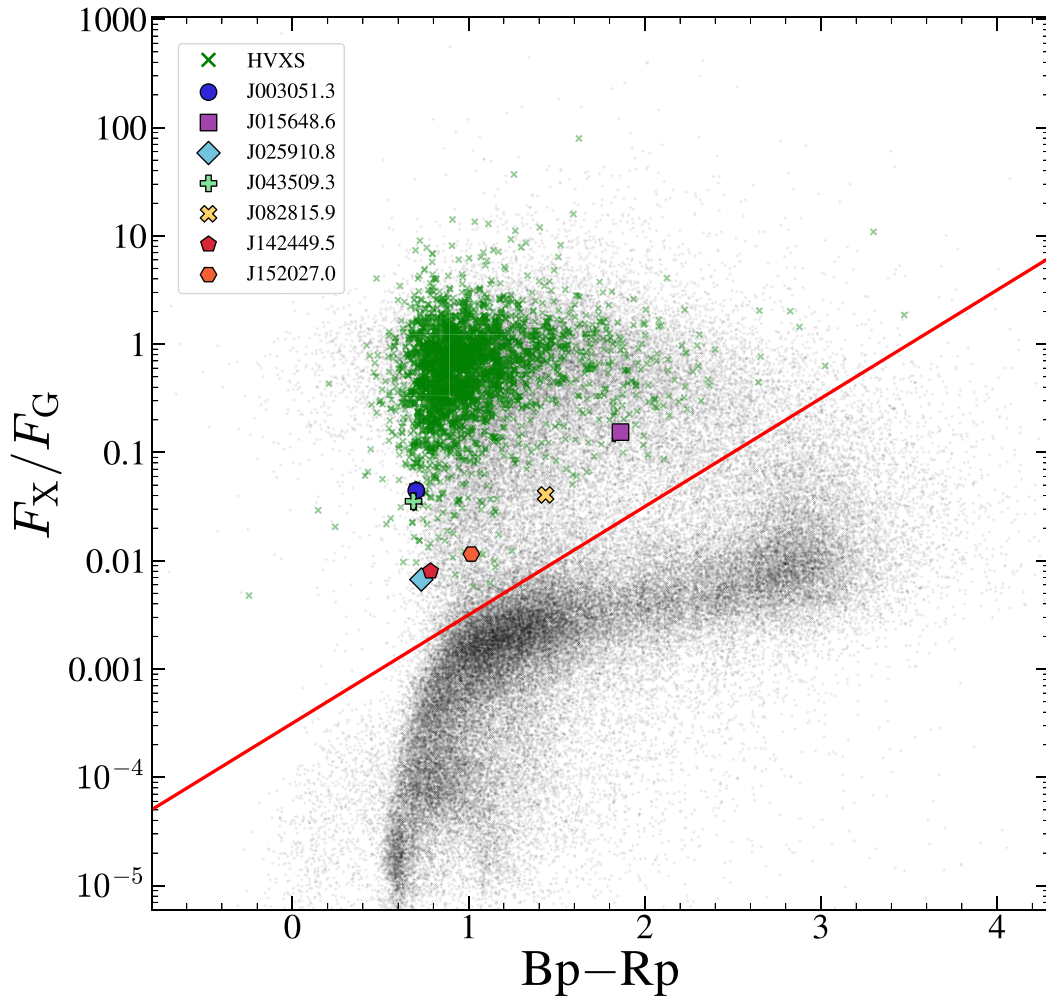

Figure 8. X-ray to *Gaia* *G*-band flux ratio (F_X/F_G) versus *Gaia* $B_p - R_p$ colours plotted for COB candidates. Black points are sources in the control sample. Sources from the gold sample are indicated by markers of distinct shapes and colours. The solid line marks the R24 empirical separatrix: $\log_{10}(F_X/F_G) = (B_p - R_p) - 3.5$.

be formed in nearby satellite galaxies and then merged with the Milky Way, exhibiting distinct kinematic and chemical features. Alternatively, high – and even runaway – velocities can be produced by dynamical processes in dense environments, such as globular clusters (e.g. J. Paradijs & N. White 1995; J. A. Irwin 2005; T. Cabrera & C. L. Rodriguez 2023) and the Galactic bulge, or close encounter with single (J. G. Hills 1988) or binary (Q. Yu & S. Tremaine 2003) massive black holes. Our search is intended to be inclusive and comprehensive, but it would greatly benefit from large-scale metallicity surveys, particularly for faint sources that are understudied in this regard.

4.3 Selection completeness and trade-offs

We began with a sizeable sample of X-ray sources, which was reduced dramatically through successive selection steps – from over 2 million sources to 2372 HVXSs. The most stringent quality cut retained only 7 sources in our ‘gold’ sample. Within the scope of existing source catalogues, two main steps contributed most to this reduction: (1) the application of a $v_{\text{pec, min, lo}}$ threshold

combined with the F_X/F_G cut (Fig. 4), and (2) the deduplication of matches and exclusion of matches beyond $2 r_{\text{err, x}}$ (Section 2.9). Due to the large uncertainties in distance estimates, many sources have correspondingly large errors on $v_{\text{pec, min}}$. As a result, applying a 1σ lower limit ($v_{\text{pec, min, lo}}$) excludes marginally fast sources with $v_{\text{pec, min}} \approx 200 \text{ km s}^{-1}$. In addition, criterion (2) removes sources located in crowded fields (e.g. the Galactic bulge), where multiple optical matches are common.

On the other hand, disc-born high-velocity systems may be inherently rare – not only because a considerable fraction are ejected, but also because those that remain bound can migrate to large distances from the disc and spend longer times there, making them harder to detect in flux-limited surveys. Beyond the current catalogues, many sky regions are yet to be covered beyond shallow depths. Future releases of eRASS with full-sky coverage, together with deeper astrometric surveys (upcoming *Gaia* DR4 and future surveys with the Roman telescope and others), will enable us to push deeper and circumvent our selection biases. Ultimately, these should help to better understand the selection function and extract underlying population densities of the fast-moving X-ray source population.

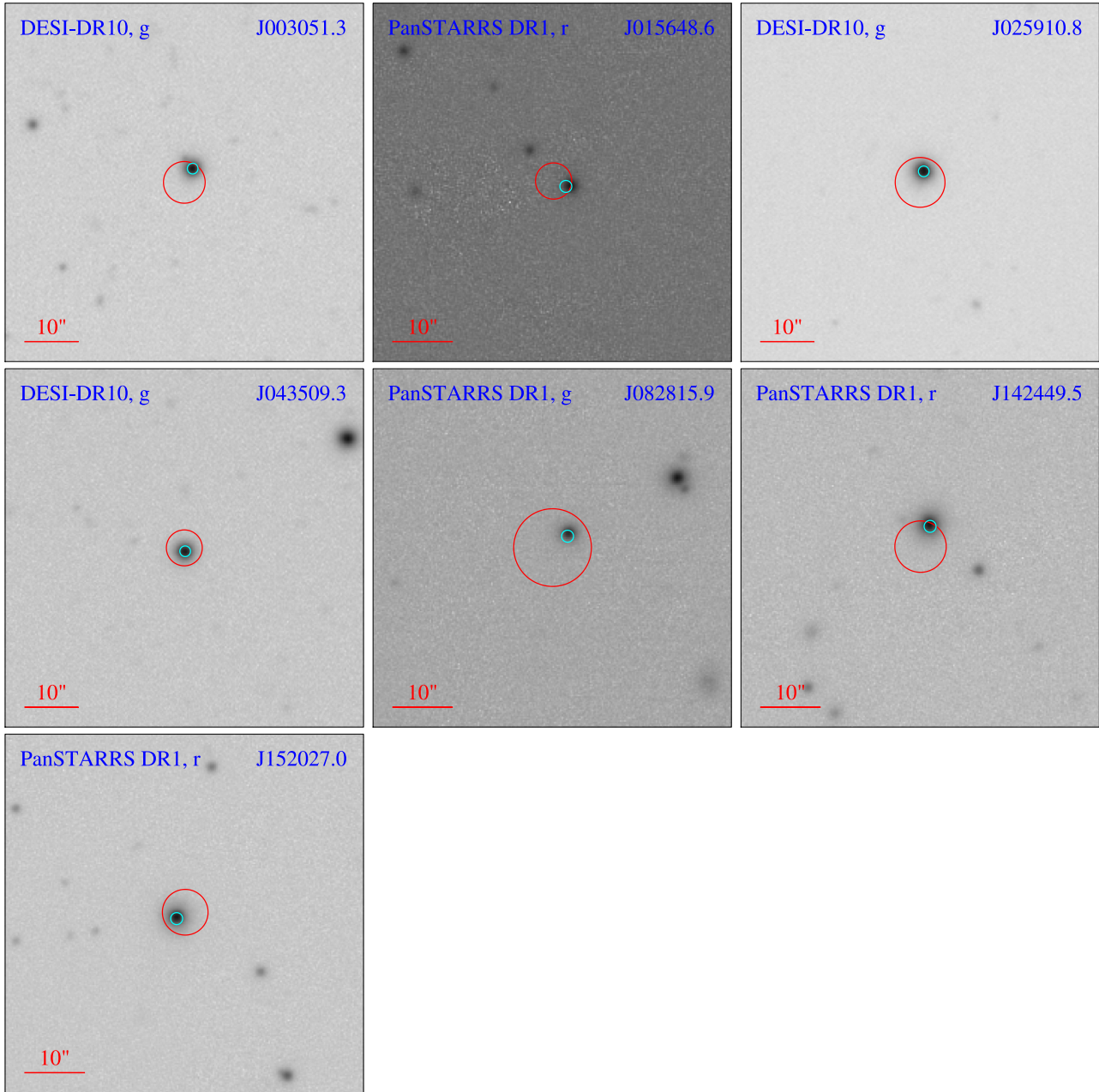

Figure 9. Optical finding charts for 7 gold sources showing $60 \text{ arcsec} \times 60 \text{ arcsec}$ fields centred on the X-ray positions; north is up and east is to the left. The X-ray error radius ($r_{\text{err},x}$) is shown by the red circle, and the *Gaia* counterpart is indicated by a cyan circle.

5 CONCLUSIONS

We have compared the distributions of v_{pec} of known compact object binaries (COBs) with that of major contaminants and found that 200 km s^{-1} can exclude over 97 per cent of contaminants. Adopting this limit on the 1σ lower limit of $v_{\text{pec},\text{min}}$, we performed a comprehensive search for HVXs that exhibit F_X/F_G ratios clearly over the empirical limit found by R24. We found a total of 2372 sources with confident counterparts, and we curated a gold sample of 7 sources. These X-ray sources may originate from COBs and can be followed-up for features of interaction (e.g. accretion). Metallicity constraints from future large-scale spectroscopic surveys will further distinguish their origins.

ACKNOWLEDGEMENTS

We thank the anonymous reviewer for their helpful comments. PG is a Royal Society Senior Leverhulme Trust fellow, and also thanks STFC for support. PC acknowledges the Leverhulme Trust for an Emeritus Fellowship. The work of DS was carried out at the Jet Propulsion Laboratory, California Institute of Technology, under a contract with the National Aeronautics and Space Administration (80NM0018D0004).

This work has made use of data and resources from the following: The European Space Agency (ESA) mission *Gaia* (<https://www.cosmos.esa.int/gaia>), processed by the *Gaia* Data Processing and Analysis Consortium (DPAC, <https://www.cosmos.esa.int/web/gaia/dpac/consortium>). Funding for the DPAC has

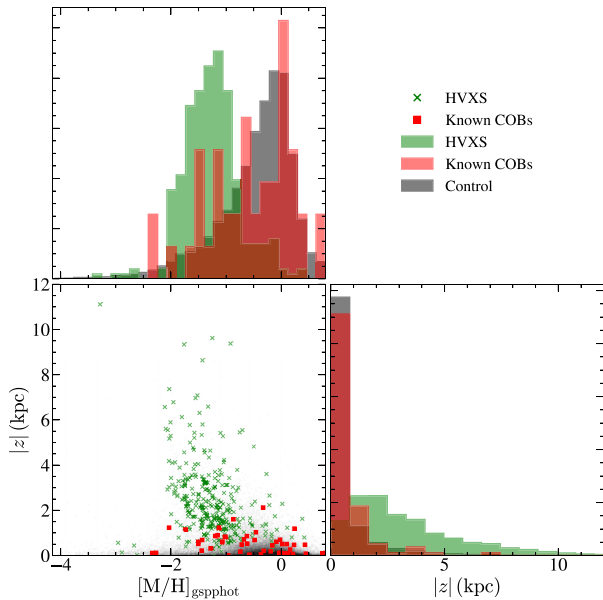

Figure 10. Vertical separation from the Galactic plane ($|z|$) plotted against the *Gaia* GSP-Phot metallicities ($[M/H]_{\text{gspphot}}$) for the control (grey scale) and HVXS samples (crosses), as well as a subset of known COBs that have $[M/H]_{\text{gspphot}}$ values (filled squares). We use the median of $|z|$ and the nominal estimates of $[M/H]_{\text{gspphot}}$ for the plots. HVXSs exhibits a broader distribution of $|z|$ and are generally more metal poor than the control sample.

been provided by national institutions, in particular the institutions participating in the *Gaia* Multilateral Agreement; the cross-match service provided by CDS, Strasbourg; the SIMBAD data base, operated at CDS, Strasbourg, France; the Aladin Sky Atlas, CDS, Strasbourg Astronomical Observatory, France. X-ray source catalogues are from multiple resources, including data obtained from the Chandra Source Catalogue (doi:10.25574/csc2), provided by the Chandra X-ray Center (CXC), the 4XMM *XMM-Newton* serendipitous source catalogue compiled by the *XMM-Newton* Survey Science Centre, the *Swift* XRT Point Source catalogue obtained from the UK Swift Science Data Centre at the University of Leicester, and the *eROSITA* all-sky survey catalogue. *eROSITA* is the soft X-ray instrument aboard SRG, a joint Russian–German science mission supported by the Russian Space Agency (Roskosmos), in the interests of the Russian Academy of Sciences represented by its Space Research Institute (IKI), and the Deutsches Zentrum für Luft- und Raumfahrt (DLR). The SRG spacecraft was built by Lavochkin Association (NPOL) and its subcontractors, and is operated by NPOL with support from the Max Planck Institute for Extraterrestrial Physics (MPE). The development and construction of the *eROSITA* X-ray instrument was led by MPE, with contributions from the Dr Karl Remeis Observatory Bamberg & ECAP (FAU Erlangen–Nuernberg), the University of Hamburg Observatory, the Leibniz Institute for Astrophysics Potsdam (AIP), and the Institute for Astronomy and Astrophysics of the University of Tübingen, with the support of DLR and the Max Planck Society. The Argelander Institute for Astronomy of the University of Bonn and the Ludwig Maximilians Universität Munich also participated in the science preparation for *eROSITA*.

This work also made use of images from the SkyMapper Southern Sky Survey. The national facility capability for SkyMapper has been funded through ARC LIEF grant LE130100104 from the Australian Research Council, awarded to the University of Sydney, the Australian National University, Swinburne University of Technology, the University of Queensland, the University of Western Australia, the University of Melbourne, Curtin University of Technology, Monash University and the Australian Astronomical Observatory. SkyMapper is owned and operated by The Australian National University’s Research School of Astronomy and Astrophysics. The survey data were processed and provided by the SkyMapper Team at ANU. The SkyMapper node of the All-Sky Virtual Observatory (ASVO) is hosted at the National Computational Infrastructure (NCI). Development and support of the SkyMapper node of the ASVO has been funded in part by Astronomy Australia Limited (AAL) and the Australian Government through the Commonwealth’s Education Investment Fund (EIF) and National Collaborative Research Infrastructure Strategy (NCRIS), particularly the National eResearch Collaboration Tools and Resources (NeCTAR) and the Australian National Data Service Projects (ANDS)

In addition to the software mentioned in the texts, analysis and visualisation in this work have also made use of the following packages (in alphabetic order): *ASTROPY*:⁷ a community-developed core Python package and an ecosystem of tools and resources for astronomy (Astropy Collaboration 2022), *MATPLOTLIB* (J. D. Hunter 2007), *NETWORKX* (A. A. Hagberg et al. 2008), *NUMPY* (C. R. Harris et al. 2020), *PANDAS* (T. team 2023), *SCIPY* (P. Virtanen et al. 2020), and *TOPCAT* (M. B. Taylor 2005).

DATA AVAILABILITY

The X-ray source catalogues used in this work are all publicly available and has been updated regularly. The *Chandra* Source Catalogue 2.1 can be accessed and queried using the CSCview application⁸, the *XMM-Newton* Serendipitous Source Catalogue can be downloaded directly from the *XMM-Newton* Survey Science Center⁹, the *Swift* Point Source Catalogue can be downloaded from the official website¹⁰, and finally, the *eRASS* DE DR1 source catalogue can be accessed and downloaded from the DR1 website¹¹. All *Gaia*-related catalogues can be accessed through the *Gaia* archive.¹² The HVXS catalogue will be made available through CDS upon publication. The code used in this work is maintained in a publicly available GitHub repository¹³. Any additional data products generated in this work are available from the lead or corresponding author upon reasonable request.

REFERENCES

- Ak T., Bilir S., Özdönmez A., Soydugan F., Soydugan E., Püsküllü Ç., Ak S., Eker Z., 2015, *Ap&SS*, 357, 72
Andrae R. et al., 2023, *A&A*, 674, A27

⁷<http://www.astropy.org>

⁸<https://cda.cfa.harvard.edu/cscview/>

⁹<https://xmmssc.aip.de/cms/catalogues/4xmm-dr14s/>

¹⁰<https://www.swift.ac.uk/2SXPS/>

¹¹https://erossita.mpe.mpg.de/dr1/AllSkySurveyData_dr1/Catalogues_dr1/

¹²<https://gea.esac.esa.int/archive/>

¹³https://github.com/coryzh/hvxs_zhao_2026.git

- Arras P., Lai D., 1999, *ApJ*, 519, 745
- Astropy Collaboration et al., 2022, *ApJ*, 935, 167
- Atri P. et al., 2019, *MNRAS*, 489, 3116
- Avakyan A., Neumann M., Zainab A., Doroshenko V., Wilms J., Santangelo A., 2023, *A&A*, 675, A199
- Bahramian A. et al., 2021, *MNRAS*, 501, 2790
- Bailer-Jones C. A. L., Rybizki J., Fouesneau M., Demleitner M., Andrae R., 2021, *AJ*, 161, 147 (B21)
- Baskill D. S., Wheatley P. J., Osborne J. P., 2005, *MNRAS*, 357, 626
- Bernardini F., Russell D. M., Kolojonen K. I. I., Stella L., Hynes R. I., Corbel S., 2016, *ApJ*, 826, 149
- Blaauw A., 1961, *Bull. Astron. Inst. Netherlands*, 15, 265
- Bogovalov S. V., Khangulyan D., Koldoba A., Ustyugova G. V., Aharonian F., 2019, *MNRAS*, 490, 3601
- Boller T., Freyberg M. J., Trümper J., Haberl F., Voges W., Nandra K., 2016, *A&A*, 588, A103
- Bovy J., 2015, *ApJS*, 216, 29
- Brandt N., Podsiadlowski P., 1995, *MNRAS*, 274, 461
- Budavári T., Szalay A. S., 2008, *ApJ*, 679, 301
- Cabrera T., Rodriguez C. L., 2023, *ApJ*, 953, 19
- Canbay R., AK T., Bilir S., Soydugan F., Eker Z., 2025, *AJ*, 169, 87
- Chambers K. C. et al., 2016, preprint (arXiv:1612.05560)
- Chawla C., Chatterjee S., Breivik K., 2025, preprint (arXiv:2508.21805)
- Chugai N. N., 1984, *Soviet Astron. Lett.*, 10, 87
- Ciešlar M., Bulik T., Osłowski S., 2020, *MNRAS*, 492, 4043
- Corral-Santana J. M., Casares J., Muñoz-Darias T., Bauer F. E., Martínez-Pais I. G., Russell D. M., 2016, *A&A*, 587, A61
- Dashwood Brown C., Gandhi P., Zhao Y., 2024, *MNRAS*, 527, L82
- Delchambre L. et al., 2023, *A&A*, 674, A31
- Dempsey R. C., Linsky J. L., Fleming T. A., Schmitt J. H. M. M., 1997, *ApJ*, 478, 358
- Dey A. et al., 2019, *AJ*, 157, 168
- Dorofeev O. F., Rodionov V. N., Ternov I. M., 1985, *Soviet Astron. Lett.*, 11, 123
- Dvali G., Gomez C., 2013, *Phys. Lett. B*, 719, 419
- Eker Z. et al., 2008, *MNRAS*, 389, 1722
- El-Badry K. et al., 2023, *MNRAS*, 521, 4323
- El-Badry K. et al., 2024, *Open J. Astrophys.*, 7, 58
- Evans I. N. et al., 2024, *ApJS*, 274, 48
- Evans P. A. et al., 2020, *ApJS*, 247, 54
- Faucher-Giguère C.-A., Kaspi V. M., 2006, *ApJ*, 643, 332
- Feigelson E. D., Montmerle T., 1999, *ARA&A*, 37, 363
- Fleming T. A., Gioia I. M., Maccacaro T., 1989, *ApJ*, 340, 1011
- Fortin F., García F., Chaty S., Chassande-Mottin E., Simaz Bunzel A., 2022, *A&A*, 665, A31
- Frank J., King A., Raine D., 1992, *Accretion power in astrophysics.. Vol. 21* Cambridge Univ. Press, Cambridge
- Gaia Collaboration, 2016, *A&A*, 595, A1
- Gaia Collaboration, 2023, *A&A*, 674, A1
- Gaia Collaboration, 2024, *A&A*, 686, L2
- Gandhi P., Rao A., Johnson M. A. C., Paice J. A., Maccarone T. J., 2019, *MNRAS*, 485, 2642
- Gandhi P. et al., 2022, *MNRAS*, 510, 3885
- Giddings S. B., 2014, *Phys. Rev. D*, 90, 124033
- Gomel R. et al., 2023, *A&A*, 674, A19
- González Hernández J. I., Rebolo R., Israelian G., 2008, *A&A*, 478, 203
- Güdel M., 2004, *A&A Rev.*, 12, 71
- Gullón M., Miralles J. A., Viganò D., Pons J. A., 2014, *MNRAS*, 443, 1891
- Hagberg A. A., Schult D. A., Swart P. J., 2008, in *Varoquaux G., Vaught T., Millman J., eds, Proceedings of the 7th Python in Science Conference. SciPy*, Pasadena, CA, USA, p. 11
- Harris C. R. et al., 2020, *Nature*, 585, 357
- Hills J. G., 1988, *Nature*, 331, 687
- Hobbs G., Lorimer D. R., Lyne A. G., Kramer M., 2005, *MNRAS*, 360, 974
- Hunt E. L., Reffert S., 2023, *A&A*, 673, A114
- Hunter J. D., 2007, *Comput. Sci. Eng.*, 9, 90
- Irwin J. A., 2005, *ApJ*, 631, 511
- Janka H.-T., 2012, *Annual Review of Nuclear and Particle Science*, 62, 407
- Jennings R. J., Kaplan D. L., Chatterjee S., Cordes J. M., Deller A. T., 2018, *ApJ*, 864, 26
- Jiménez-Arranz Ó. et al., 2023a, *A&A*, 669, A91
- Jiménez-Arranz Ó., Romero-Gómez M., Luri X., Masana E., 2023b, *A&A*, 672, A65
- Jonker P. G. et al., 2011, *ApJS*, 194, 18
- Khamitov I. M., Bikmaev I. F., Gilfanov M. R., Sunyaev R. A., Medvedev P. S., Gorbachev M. A., Irtuganov E. N., 2023, preprint (arXiv:2301.08010)
- Kleihaus B., Kunz J., Radu E., 2011, *Phys. Rev. Lett.*, 106, 151104
- Lattimer J. M., 2012, *Annu. Rev. Nucl. Part. Sci.*, 62, 485
- Leahy D. A., Abdallah M. H., 2014, *ApJ*, 793, 79
- Lyne A. G., Lorimer D. R., 1994, *Nature*, 369, 127
- Manchester R. N., Hobbs G. B., Teoh A., Hobbs M., 2005, *AJ*, 129, 1993
- Martin D. C. et al., 2005, *ApJ*, 619, L1
- Marton G. et al., 2019, *MNRAS*, 487, 2522
- Merloni A. et al., 2024, *A&A*, 682, A34
- Mirabel I. F., Dhawan V., Mignani R. P., Rodrigues I., Guglielmetti F., 2001, *Nature*, 413, 139
- Motch C., Haberl F., Dennerl K., Pakull M., Janot-Pacheco E., 1997, *A&A*, 323, 853
- Nebot Gómez-Morán A. et al., 2013, *A&A*, 553, A12
- Nelemans G., Tauris T. M., van den Heuvel E. P. J., 1999, *A&A*, 352, L87
- Neumann M., Avakyan A., Doroshenko V., Santangelo A., 2023, *A&A*, 677, A134
- O'Doherty T. N., Bahramian A., Miller-Jones J. C. A., Goodwin A. J., Mandel I., Willcox R., Atri P., Strader J., 2023, *MNRAS*, 521, 2504
- Olejak A., Belczynski K., Bulik T., Sobolewska M., 2020, *A&A*, 638, A94
- Onken C. A., Wolf C., Bessell M. S., Chang S.-W., Luvaul L. C., Tonry J. L., White M. C., Da Costa G. S., 2024, *PASA*, 41, e061
- van Paradijs J., White N., 1995, *ApJ*, 447, L33
- Pecaut M. J., Mamajek E. E., 2013, *ApJS*, 208, 9
- Predehl P. et al., 2021, *A&A*, 647, A1
- Reid M. J. et al., 2009, *ApJ*, 700, 137
- Reid M. J., McClintock J. E., Steiner J. F., Steeghs D., Remillard R. A., Dhawan V., Narayan R., 2014, *ApJ*, 796, 2
- Reis R. C., Wheatley P. J., Gänsicke B. T., Osborne J. P., 2013, *MNRAS*, 430, 1994
- Ritter H., Kolb U., 2003, *A&A*, 404, 301
- Rodriguez A. C., 2024, *PASP*, 136, 054201
- Rybizki J. et al., 2022, *MNRAS*, 510, 2597
- Salvato M. et al., 2018, *MNRAS*, 473, 4937
- Schlafly E. F. et al., 2018, *ApJS*, 234, 39
- Seppi R. et al., 2022, *A&A*, 665, A78
- Shahaf S., Bashi D., Mazeh T., Faigler S., Arenou F., El-Badry K., Rix H. W., 2023, *MNRAS*, 518, 2991
- Shahbaz T., González-Hernández J. I., Breton R. P., Kennedy M. R., Mata Sánchez D., Linares M., 2022, *MNRAS*, 513, 71
- Shaw A. W. et al., 2020, *MNRAS*, 492, 4344
- Shen Y. et al., 2021, *Nat. Astron.*, 5, 569
- Taylor M. B., 2005, in *Shopbell P., Britton M., Ebert R., eds, ASP Conf. Ser. Vol. 347, Astronomical Data Analysis Software and Systems XIV. Astron. Soc. Pac., San Francisco*, p. 29
- Thompson T. A. et al., 2019, *Science*, 366, 637
- Tranin H., Godet O., Webb N., Primorac D., 2022, *A&A*, 657, A138
- Truemper J., 1982, *Adv. Space Res.*, 2, 241
- Vilhu O., 1984, *A&A*, 133, 117
- Vilhu O., Rucinski S. M., 1983, *A&A*, 127, 5
- Vilhu O., Walter F. M., 1987, *ApJ*, 321, 958
- Virtanen P. et al., 2020, *Nat. Methods*, 17, 261
- Voges W. et al., 1996, *IAU Circ.*, 6420, 2
- Voges W. et al., 1999, *A&A*, 349, 389
- Voges W. et al., 2000, *IAU Circ.*, 7432, 3
- Walter F., Charles P., Bowyer S., 1978a, *ApJ*, 225, L119
- Walter F., Charles P., Bowyer S., 1978b, *Nature*, 274, 569
- Walter F. M., Bowyer S., 1981, *ApJ*, 245, 671
- Wang S., Bai Y., He L., Liu J., 2020, *ApJ*, 902, 114
- Wang Y. et al., 2025, preprint (arXiv:2507.14400)

- Webb N. A. et al., 2020, *A&A*, 641, A136
Wright N. J., Drake J. J., Mamajek E. E., Henry G. W., 2011, *ApJ*, 743, 48
Yu Q., Tremaine S., 2003, *ApJ*, 599, 1129
Zainab A. et al., 2024, preprint (*A&A* 693 16
Zhao Y., Gandhi P., Dashwood Brown C., Knigge C., Charles P. A., Mac-
carone T. J., Nuchvanichakul P., 2023, *MNRAS*, 525, 1498
pandas development team T., 2023, *pandas-dev/pandas: Pandas*, <https://doi.org/10.5281/zenodo.7979740>

APPENDIX A: ADDITIONAL TABLES

A1 Kept SIMBAD types

Table A1 lists SIMBAD types kept in our selection (Section 2.9).

A2 Acronyms and symbols

This section lists acronyms (Table A2) and symbols (Table A3) defined throughout the texts.

Table A1. Kept SIMBAD types.

Type	Counts	Type	Counts	Type	Counts
Radio	41	cmRad	2	Transient	1
Star	37	RotV*	1	WhiteDwarf_Candidate	1
X	19	Variable*	1		
EclBin	9	Eruptive*	1		
HighPM*	6	ChemPec*	1		
	2	Low-Mass*	1		
LongPeriodV*		blue	1		
gammaBurst					

Table A2. Acronyms (in alphabetic order) used in this work.

Acronym	Definition
AGN	Active galactic nucleus
BH	Black hole
BPSR	Binary pulsar
COB	Compact object binary
CSC	<i>Chandra</i> Source Catalogue
CV	Cataclysmic variable
eRASS	<i>eROSITA</i> All-Sky Survey
GSP-Phot	General Stellar Parametrizer from Photometry module
HMXB	High-mass X-ray binary
HVXS	High-velocity X-ray source
LMC	Large Magellanic Cloud
LMXB	Low-mass X-ray binary
LSR	Local standard of rest
NICOB	Non-interacting compact object binary
NK	Natal kick
NS	Neutron star
PM	Proper motion
RV	Radial velocity
SMC	Small Magellanic Cloud
XRb	X-ray binary
YSO	Young stellar object

Table A3. Symbols defined in this work.

Symbol	Definition
α	Right ascension
δ	Declination
$\mu_\alpha \cos \delta$	PM component in the direction of α
μ_δ	PM component in the direction of δ .
ϖ	Parallax
σ_ϖ	Uncertainty in ϖ
d_{b21}	Distance from C. A. L. Bailer-Jones et al. (2021)
d_{inv}	Distance from inverting ϖ
ϵ	Astrometric excess noise
σ_ϵ	Significance of ϵ
v_{pec}	Peculiar velocity relative to Galactic rotation
$v_{pec,min}$	Minimum peculiar velocity
$v_{pec,min,lo}$	1σ lower limit of $v_{pec,min}$
γ	Systemic radial velocity
γ_{min}	γ value that minimises v_{pec}
$\delta_{x,g}$	Angular separation of <i>Gaia</i> counterpart to X-ray position
$r_{err,x}$	Uncertainty in X-ray position
M_G	Absolute <i>Gaia</i> G-band magnitude
G	Apparent <i>Gaia</i> G-band magnitude
Bp – Rp	<i>Gaia</i> Bp–Rp colour
F_X/F_G	X-ray/ <i>Gaia</i> G flux ratio
$[M/H]_{gspphot}$	<i>Gaia</i> GSP-Phot metallicity
$ z $	Vertical separation from the Galactic plane

This paper has been typeset from a $\text{\TeX}/\text{\LaTeX}$ file prepared by the author.