

NOVEL INTERROGATING SYSTEM FOR FIBRE BRAGG GRATING SENSORS USING AN ACOUSTO-OPTIC TUNABLE FILTER

M. G. Xu, H. Geiger, J. L. Archambault, L. Reekie and J. P. Dakin

Indexing terms: Fibre optic sensors, Acousto-optical devices, Fibre gratings

A new technique for the interrogation of in-fibre Bragg grating sensors using an acousto-optic tunable filter (AOTF) is demonstrated. The scheme involves frequency shift keying (FSK) of the RF drive to the AOTF to track the wavelength shifts of a Bragg grating. Experimental results are presented for temperature measurement. This technique provides a frequency-agile system, capable of rapid, random access and very wide tuning range.

Introduction: Fibre optic Bragg grating sensors are attracting considerable interest for a number of sensing applications [1-9] because of their intrinsic and wavelength-encoded operation. There is great interest in the multiplexed sensing of smart structures and materials, particularly for real-time evaluation of physical measurands (e.g. temperature, strain) at critical monitoring points. To interrogate and demultiplex a number of in-fibre Bragg grating sensors, whether they are in a common fibre path or not, it is necessary that the instantaneous central wavelength of each sensor can be identified.

Various schemes to detect small peak wavelength shifts of the gratings have been developed [5-9]. These include the edge-filter demodulation method [5] where a sharp edge of a filter is used to convert wavelength changes to amplitude variations, interferometric-based approaches [6, 7], the use of frequency-locked grating pairs [8] and laser-sensor concepts where the sensor is an active lasing device that determines the frequency [4, 9].

However, all the above methods have limitations when it is desired to interrogate the wavelength of a large number of fibre gratings in a frequency-agile manner. In this Letter we present a new method of constructing an interrogating system for in-fibre Bragg grating sensors using an acousto-optic tunable filter. This type of filter possesses the desired frequency-agile capability for random access and has a wide tuning range [10]. At constant temperature, its peak transmission wavelength is determined solely by the frequency of an RF drive signal and it is therefore suitable for both dynamic and quasistatic strain sensing and for multiplexed sensing systems. In addition, the same detection system can be used to measure the Bragg wavelengths of the gratings in either reflective or transmissive configuration.

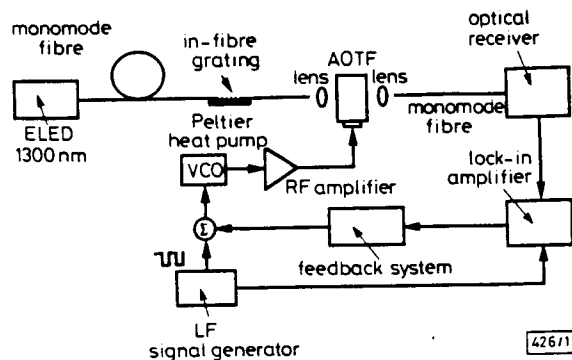

Fig. 1 Schematic diagram of arrangement of experiment

Principle: Our experimental system is shown schematically in Fig. 1. Light from a broadband optical source (ELED) is coupled, via the in-fibre grating to be measured, through the AOTF and then to a detector. The operating principle of the transmission type of AOTF is described in detail elsewhere [10]. As already mentioned, the wavelength of the light transmitted by the AOTF is a function of the RF frequency. To track the instantaneous Bragg wavelength, it is feasible to employ a feedback signal to lock the mean optical wavelength of the filter to the instantaneous Bragg wavelength of the in-fibre grating. This involves dithering the applied RF frequency about a nominal value (i.e. FSK) and detecting the amplitude modulation of the received optical carrier. Assuming that the AOTF mean wavelength is proportional to applied RF frequency over the measurand-induced wavelength shift of each in-fibre grating, then for symmetrical grating and filter responses, the amplitude modulation of the dither frequency is zero when the mean wavelength of the AOTF coincides with the Bragg wavelength of the grating. This condition can be achieved by adjusting the mean frequency of the FSK signal.

The FSK signal is conveniently generated using a voltage controlled oscillator (VCO), with a low-frequency squarewave input plus a DC bias signal to tune the mean frequency. The electronics system shown in Fig. 1 should serve to lock the mean frequency of the AOTF to the condition where the amplitude modulation is zero. The mean frequency of the VCO would then provide an indication of the corresponding instantaneous Bragg wavelength of the sensor. For multiplexing, it would, of course, be necessary to apply an impulse to the VCO input to cause it to address and then lock onto a different in-fibre grating. Alternatively the filter could be simultaneously driven by multiple RF signals of different frequencies, each set to track a particular grating as described above.

Experiment and discussion: In our experimental demonstration, we have shown the basic concept to be feasible by operating the system in open loop configuration. The broadband source used was a 1300 nm singlemode fibre-pigtailed ELED, which launched $\sim 50 \mu\text{W}$ of output power over a $\sim 56 \text{ nm}$ bandwidth (FWHM). The sensing grating, having a nominal (i.e. unstrained and at room temperature) Bragg wavelength of $\sim 1298 \text{ nm}$, a peak reflectivity of 99% and a bandwidth of $\sim 1 \text{ nm}$ (FWHM), was incorporated between the optical source and the AOTF. The AOTF (Crystal Technology, MID-IR AOTF) had a wavelength tuning range of 1.2-2.5 μm

and a resolution (FWHM) of 4 nm. We used a commercial RF signal generator (Marconi 2031) as a VCO. The frequency deviation of the FSK-modulated drive signal to the AOTF was chosen to be 360 kHz to obtain optimum sensitivity for the particular AOTF/grating configuration. The mean RF drive frequency was manually chosen to be 111.58 MHz to set the mean AOTF wavelength to the nominal Bragg wavelength.

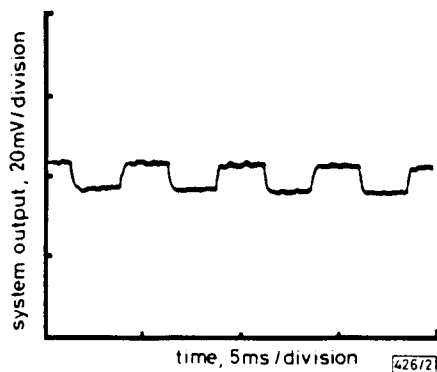

Fig. 2 System output from optical receiver when RF frequency is detuned from matching condition

Fig. 2 shows the system output from the optical detector, with the modulation-input frequency to the VCO set to 200 Hz, and with the mean RF frequency detuned from the matching condition. The modulation signal at the detector becomes zero only when the mean AOTF wavelength matches the instantaneous Bragg-grating wavelength. For the purpose of our initial feasibility experiment, the temperature measurement results shown in Fig. 3 were obtained by heating the Bragg grating using a Peltier heat pump. The temperature sensitivity of the Bragg grating was measured to be $-0.95 \text{ kHz}/^\circ\text{C}$, in terms of RF frequency shifts, a value in close agreement with the value expected [3]. Clearly similar results are expected if the in-fibre grating were to be stretched ($-0.098 \text{ kHz}/\mu\text{e}^1$) or pressurised ($0.26 \text{ kHz}/\text{MPa}^3$), provided the same AOTF is used at same wavelength.

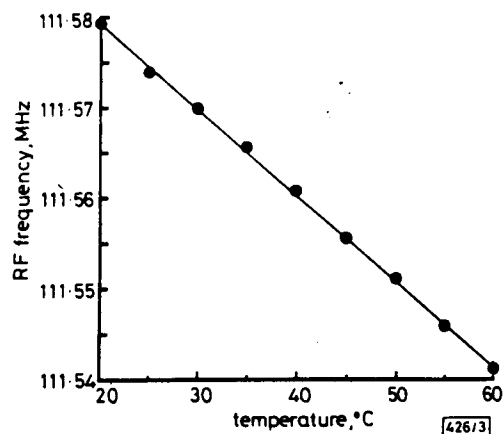

Fig. 3 Tracking of in-fibre Bragg grating subject to thermal variation

$$f(\text{MHz}) = -0.00095T(^\circ\text{C}) + 111.6$$

● measurements
— linear fit

Conclusions: We have demonstrated an attractive method for the interrogation of a Bragg grating sensor using an acousto-optic tunable filter. Although in our first experiment, this was for thermal monitoring, strain or pressure measurement should equally be possible. This technique offers considerable advantage over previous approaches. In particular the method has the potential for frequency-agile access, wide tuning range, and the ability to recover after transient signal loss etc., all of which are likely required in practical multiplexing applications. The system developed is therefore likely to provide a practical means for interrogating multiplexed in-fibre Bragg grating sensors.

Acknowledgments: The ORC is a UK government funded (SERC) Interdisciplinary Research Centre. The programme

has been supported by ESA/ESTEC research centre, Noordwijk, NL. The authors would also like to thank R. Heath-Whyte of Laser Service, Ltd. for the loan of the AOTF manufactured by Crystal Technology Inc.

© IEE 1993

17th June 1993

M. G. Xu, H. Geiger, J. L. Archambault, L. Reekie and J. P. Dakin (Optoelectronics Research Centre, University of Southampton, Southampton SO9 5NH, United Kingdom)

References

- MOREY, W. W., MELTZ, G., and GLENN, W. H.: 'Fibre optic Bragg grating sensor'. Proc. SPIE, 1989, **1169**, pp. 98-107
- MOREY, W. W., and MELTZ, G.: 'Evaluation of a fibre Bragg grating hydrostatic pressure sensor'. Proc. OFS'8, Monterey, 1992, Post-deadline Paper PD-4
- XU, M. G., REEKIE, L., CHOW, Y. T., and DAKIN, J. P.: 'Optical in-fibre grating high pressure sensor', *Electron. Lett.*, 1993, **29**, (4), pp. 398-399
- MELLE, S. M., ALAVIE, A. T., KARR, S., COROY, T., LIU, K., and MEASURES, R. M.: 'A Bragg grating-tuned fibre laser strain sensor system', *IEEE Photonics Technol. Lett.*, 1993, **5**, (2), pp. 263-266
- MELLE, S. M., LIU, K., and MEASURES, R. M.: 'A passive wavelength demodulation system for guided-wave Bragg grating sensors', *IEEE Photonics Technol. Lett.*, 1992, **4**, (5), pp. 516-518
- KERSEY, A. D., BERKOFF, T. A., and MOREY, W. W.: 'High-resolution fibre-grating based strain sensor with interferometric wavelength-shift detection', *Electron. Lett.*, 1992, **28**, (3), pp. 236-238
- KERSEY, A. D., BERKOFF, T. A., and MOREY, W. W.: 'Fibre Fabry-Perot demodulation for Bragg grating strain-sensors'. Proc. OFS'9, Florence, 1993, pp. 39-42
- JACKSON, D. A., RIBEIRO, A. B. L., REEKIE, L., ARCHAMBAULT, J. L., and RUSSELL, P. ST. J.: 'Simultaneous interrogation of fibre optic grating sensors'. Proc. OFS'9, Florence, 1993, pp. 43-46
- KERSEY, A. D., DAVIS, M. A., and MOREY, W. W.: 'Quasi-distributed Bragg-grating fibre-laser sensor'. Proc. OFS'9, Florence, 1993, Postdeadline Paper PD-5
- CHANG, I. C.: 'Acousto-optic tunable filter', *Opt. Eng.*, 1981, **20**, (6), pp. 824-829