

FIBRE-OPTIC VIBRATION PROBE

Indexing terms: Optics, Fibre optics

A practical all-fibre laser vibrometer is described. The design has been optimised for hand-held use and incorporates a frequency-scanned laser diode and a single-mode optical fibre coupler. The vibration information is extracted by a pseudo-heterodyne technique.

Introduction: Laser Doppler velocimetry (LDV) is now a well established technique for noncontact measurement of surface vibration.^{1,2} The principle relies on scattering light from a surface and observing the Doppler shift in frequency which occurs when the surface moves. To determine the direction of motion, it is necessary to optically heterodyne the scattered light with a frequency-shifted reference beam to provide a carrier frequency which is then frequency-modulated by the surface motion.

At least one commercial instrument is available² employing a Bragg cell to frequency-shift the reference beam. However, other more convenient forms of heterodyne signal processing have recently been developed. For example, Jackson *et al.*³ produced the frequency-shifted reference by ramped phase modulation using a semiconductor laser diode, while Lewin *et al.*⁴ used sinusoidal modulation of a fibre wrapped around a piezoelectric crystal. These schemes have produced carrier frequencies up to 10⁴ Hz, which severely limits the highest vibration velocity which can be measured.

In this letter we describe a fibre-optic vibrometer which avoids the use of a separate frequency-shifting device and also provides a convenient hand-held fibre probe.

Fibre vibrometer design: The vibrometer design utilises the pseudoheterodyne scheme⁴ to obtain frequency shifting. A laser diode was sinusoidally driven at 1.05 MHz to give optical phase modulation, thus avoiding linearity problems associated with ramped phase modulation,³ while generating a frequency shift of sufficient magnitude to measure large vibrations (~10⁻¹ ms⁻¹).

A diagram of the vibrometer is shown in Fig. 1. The laser output is launched into one port of a four-port single-mode fibre coupler which has one of its output ports index-matched, while collimated light from the other port illuminates the target surface. Scattered light re-enters the fibre and is directed via the four-port coupler to the detector, where it is mixed with a reflected reference signal obtained from the fibre-Selfoc interface. The arrangement ensures that the fibre path is common to both signal and reference, thus ensuring that the probe is insensitive to environmental disturbances. This factor is crucial in the design of a practical engineering instrument.

Theory: A change in drive current to a laser diode produces a frequency shift⁵ in the output radiation (~1.0 GHz/mA). Thus, sinusoidally modulating the laser drive current at a frequency ω_m sweeps the lasing frequency ν by an amount

$$\nu = \nu_0 + \Delta\nu \sin \omega_m t \tag{1}$$

where ν_0 is the mean laser frequency and $\Delta\nu$ is the peak frequency shift. The reflected light from the endface of the fibre and the scattered light from the target surface interfere at the detector to produce an intensity which is modulated by their phase difference. If l is the fibre end/target distance and is large ($l > 50$ mm), such that amplitude modulation of the laser at frequency ω_m can be ignored, the current output from the detector, $i(t)$, is

$$i(t) = \beta(1 + K \cos \{\phi_m \sin \omega_m t + \phi_T\}) \tag{2}$$

where β is a constant relating to optical power and detector sensitivity, K is a measure of the scattered signal amplitude (the 'fringe visibility'), and

$$\phi_m = 4\pi l \frac{\Delta\nu}{c} \quad \text{and} \quad \phi_T = 4\pi l \frac{\nu_0}{c} \tag{3}$$

Expanding in terms of Bessel functions we can write

$$i(t) = \beta(1 + K \{J_0(\phi_m) + 2 \sum_{n=1}^{\infty} J_{2n}(\phi_m) \cos 2n\omega_m t\} \cos \phi_T - K \{2 \sum_{n=0}^{\infty} J_{2n+1}(\phi_m) \sin (2n+1)\omega_m t\} \sin \phi_T) \tag{4}$$

It has been demonstrated⁶ that a signal of this form can be demodulated by mixing with a square wave at the fundamental frequency ω_m , and maintaining the phase excursion ($\phi_m \approx 2.82$ rad). The latter is obtained by controlling the laser drive $\Delta\nu$.

After square-wave mixing, the resultant signal is bandpass-filtered at a frequency $2\omega_m$ to give

$$i(t)_{2\omega_m} = \beta K J_2(\phi_m) \cos (2\omega_m t - \phi_T) \tag{5}$$

Here the optical phase shift ϕ_T has been transposed to a low-frequency electronic phase shift. Thus, frequency demodulation gives the surface velocity according to

$$\frac{d\phi_T}{dt} = \frac{4\pi\nu_0}{c} \frac{dl}{dt} \tag{6}$$

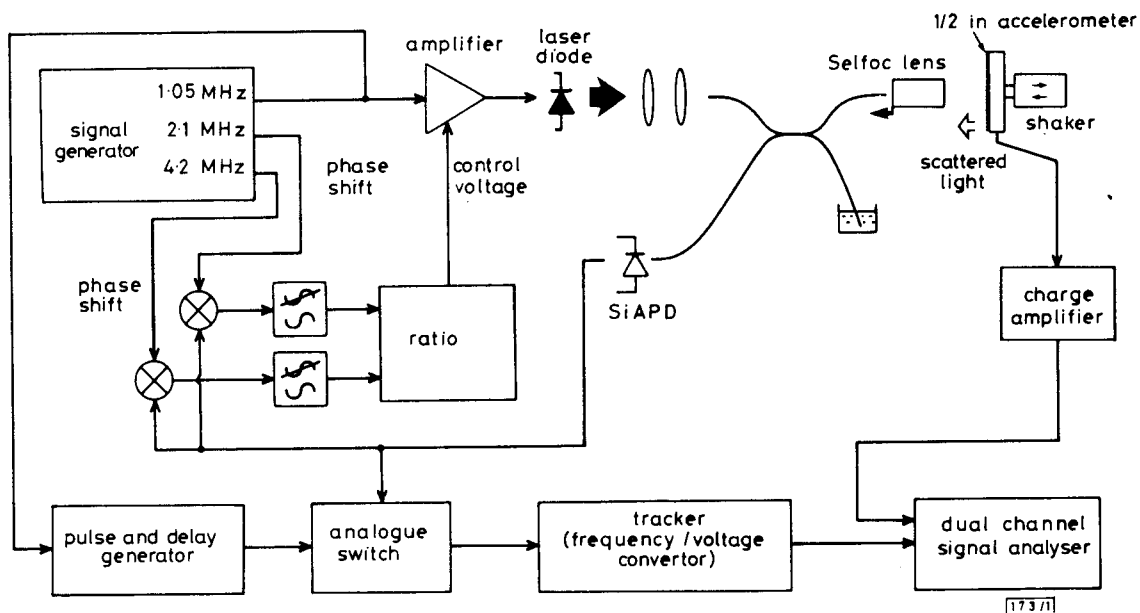

Fig. 1 Practical fibre vibrometer

Practical system: Fig. 1 shows the fibre vibrometer probe. Signals at 1.05, 2.1 and 4.2 MHz were generated and the 1.05 MHz signal used to modulate the laser through an AGC amplifier. The detector output (eqn. 4) was mixed with the 2.1 and 4.2 MHz signals in two parallel operational multipliers. Their respective outputs were lowpass-filtered to obtain $J_2(\phi_m) \cos \phi_T$ and $J_4(\phi_m) \cos \phi_T$. The ratio $J_2(\phi_m)/J_4(\phi_m)$ was obtained and used to develop a control voltage to the AGC amplifier, thus automatically controlling the frequency excursion of the laser $\Delta\nu$ to give $\phi_m = 2.82$ rad. This compensates for variations between laser diode temperature effects and the distance from the probe to the vibrating surface.

To extract the vibration information, the detector output was synchronously gated at frequency ω_m using an analogue switch. The switched output was fed to a frequency tracker which extracted the second harmonic of the signal (eqn. 5). The tracker measures $d\phi_T/dt$ and thus provides an output voltage proportional to surface velocity.

Results: Fig. 2 shows a typical comparison between measure-

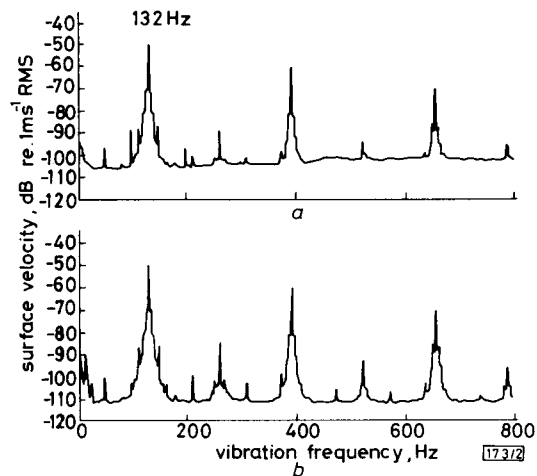

Fig. 2 Spectral plot of test surface velocity obtained using fibre vibrometer compared with that given by an accelerometer

a Fibre vibrometer
b Accelerometer

ments of surface vibration made using the fibre vibrometer and a commercial accelerometer. The surface of the two measurements was vibrated at 132 Hz with a shaker. The two measurements are in excellent agreement. The noise floor from the fibre vibrometer is marginally higher at ~ 105 dB re. 1 ms^{-1} RMS, compared to 110 dB re. 1 ms^{-1} RMS for the accelerometer. Moreover, the fibre vibrometer shows some low-frequency mains feedthrough at 50, 100, 150 and 200 Hz. Circuit modifications are in hand to improve both these areas.

Vibration frequencies up to 20 kHz have been measured, restricted only by the frequency tracker. Fig. 3 demonstrates the large velocities measurable with the vibrometer; in fact the maximum was excellent at $\pm 0.2 \text{ ms}^{-1}$, the limit being the presence of sideband frequencies associated with the odd harmonics ω_m and $3\omega_m$. If required, an even larger velocity range could be obtained by increasing the laser modulation frequency by several tens of megahertz.

The fibre vibrometer was designed to have a fibre end to target range between 50 and 300 mm. Again, this can be extended by circuit modifications.

Conclusion: We have developed a practical fibre-optic vibrometer which utilises the pseudoheterodyne scheme to avoid the use of a separate frequency shifter. The vibrometer is ideally suited to hand-held machine vibration analysis, since it is insensitive to external vibrations, is robust and lightweight, uses inexpensive components and allows access to difficult targets. Dynamic range is already close to that obtainable by other LDV methods, and further improvements are expected with some elementary refinements.

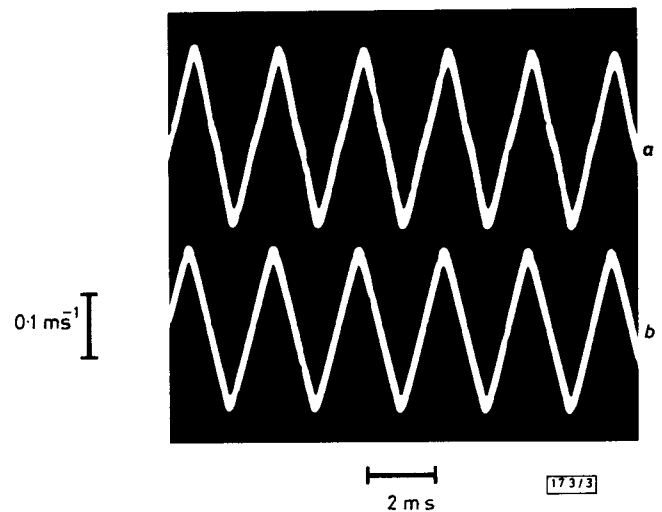

Fig. 3 Output traces of test surface velocity obtained using the two devices

Trace shows the large velocities measurable (0.29 ms^{-1} p-p)
a Fibre vibrometer
b Accelerometer

Acknowledgments: Thanks are due to S. B. Poole for helpful discussions. The work was supported by the UK Science & Engineering Research Council, and a Readership was provided by Pirelli General plc.

R. I. LAMING
M. P. GOLD
D. N. PAYNE
N. A. HALLIWELL*

5th December 1985

Department of Electronics & Information Engineering
* Institute of Sound and Vibration Research
University of Southampton
Southampton SO9 5NH, United Kingdom

References

- HALLIWELL, N. A.: 'Laser Doppler measurement of vibrating surfaces: a portable instrument', *J. Sound & Vib.*, 1979, **62**, pp. 312-315
- BUCHHAVE, P.: 'Laser Doppler vibration measurements using variable frequency shift', *DISA Inf.*, 1975, **18**, pp. 15-29
- JACKSON, D. A., KERSEY, A. D., CORKE, M., and JONES, J. D. C.: 'Pseudoheterodyne detection scheme for optical interferometers', *Electron. Lett.*, 1982, **18**, pp. 1081-1083
- LEWIN, A. C., KERSEY, A. D., and JACKSON, D. A.: 'Non-contact surface vibration analysis using a monomode fibre optic interferometer incorporating an open air path', *J. Phys. E*, 1985, **18**, pp. 604-607
- DANDRIDGE, A., and GOLDBERG, L.: 'Current-induced frequency modulation in diode lasers', *Electron. Lett.*, 1982, **18**, pp. 302-304
- KIM, B. Y., and SHAW, H. J.: 'Phase-reading, all fibre-optic gyroscope', *Opt. Lett.*, 1984, **9**, pp. 378-380